



aerospace  
climate control  
electromechanical  
**filtration**  
fluid & gas handling  
hydraulics  
pneumatics  
process control  
sealing & shielding



# 100P Series

High Pressure Filters



ENGINEERING YOUR SUCCESS.

# 100P Series

## Applications

### Features/Applications for High Pressure Hydraulic Filters 100P Series

- Pressures to 6,000 PSI
- Flows to 265 GPM
- Microglass Elements 3 to 20 Micron
- 1½" and 2" Ports - SAE O-Ring or Code 62 Flange
- Reverse Flow Option

### Specifications:

**Flow Rating:** 265 GPM

**Operating Pressure:** 6000 PSI

**Proof Pressure:** 9000 PSI

**Burst Pressure:** 12,000 PSI

**Fatigue Pressure:**

0-4000-0 PSI @ 3,000,000 cycles

**Bypass Setting:** 100 PSID

**Fluid Temperature:** -40°F to +212°F

**Construction:**

**Head and Cap:** Nodular Iron

**Bowl:** Seamless Steel Tube

**Indicators:** Brass

**Elements:** Consult Factory

**Weight:**

Length 2 - 104 Lbs.

### Electrical Ratings:

Hirschman Connector without Lamps:

- E2 - 110 VAC, .5 Amp Ind., 2 Amp Res.
- 250 VAC, .5 Amp Ind., 2 Amp Res.
- 28 VDC, 1 Amp Ind., 2 Amp Res.

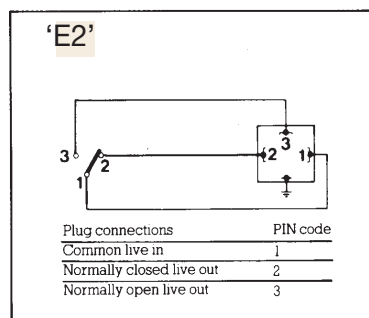

# 100P Series

## Specifications

### Dimensions Inches (mm)

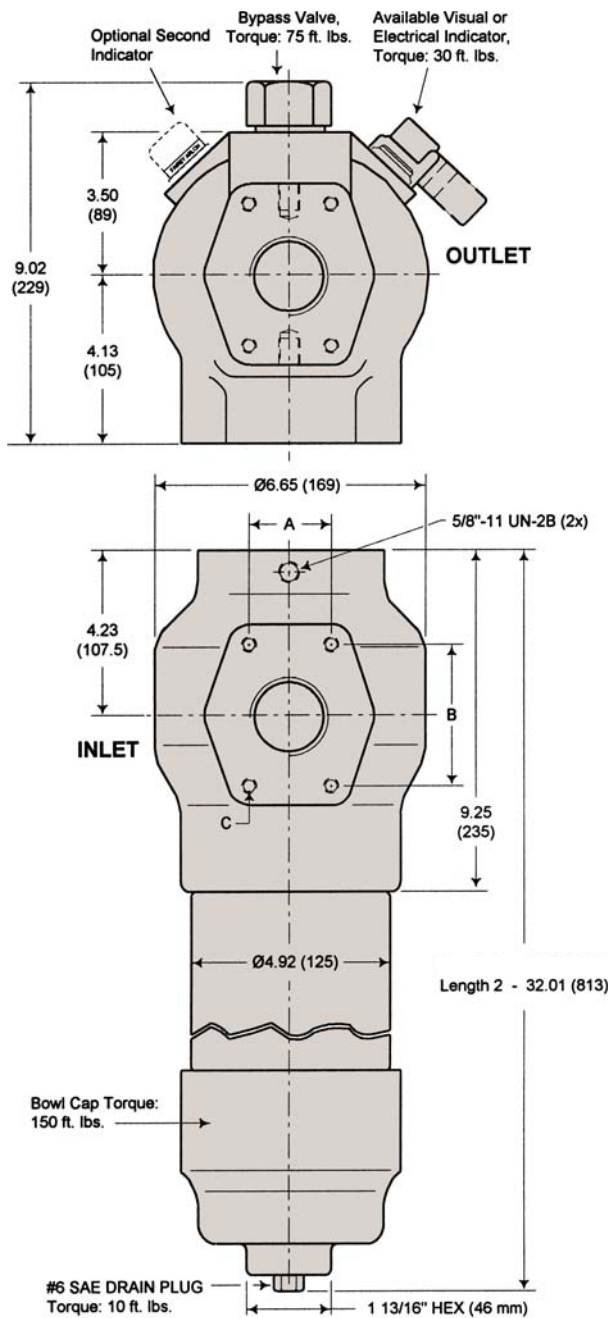

### Optional Mounting Bracket

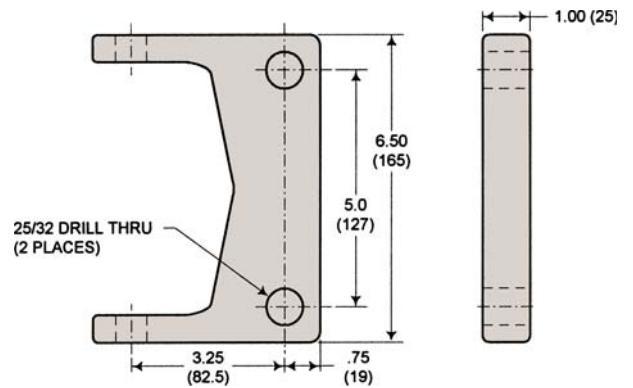

Port	Dimensions		
	A	B	C
F	1.437" 36.5mm	3.125" 79.4mm	5/8"-11 X 1.4"
T	1.750" 44.5mm	3.812" 96.8mm	3/4"-10 X 1.4"

Element Removal Clearance: Length 2 - 23.10

Drawings are for reference only.  
Contact factory for current version.

# 100P Series

## Element Performance

### Flow/Pressure Drop Data

Fluid Conditions: Viscosity 140 SSU and Sp. Gr. 0.88

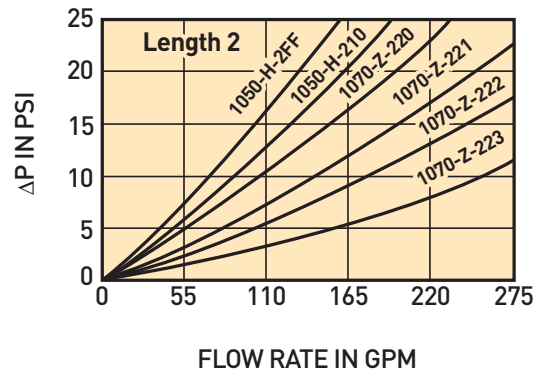
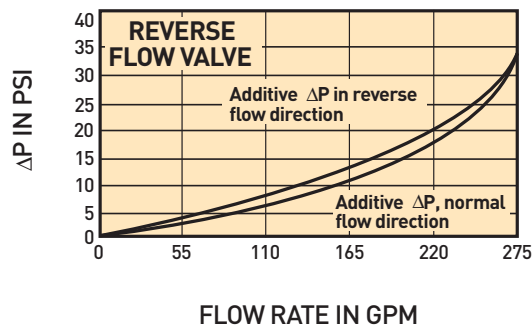
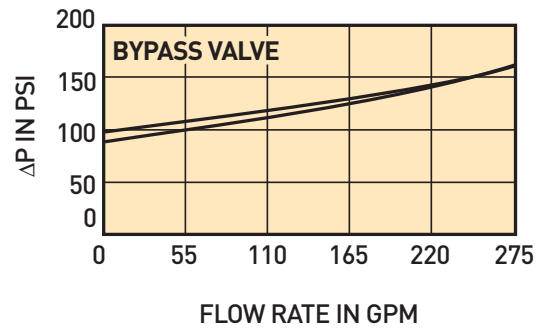
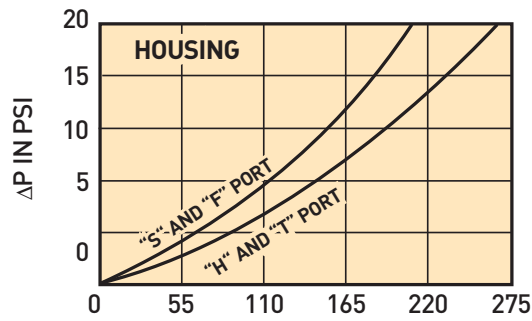

### Multipass Test Results to ISO 4572 (Time Weighted Average)

Media Code	Filtration Rating						
	$\beta_x \geq 100$	$\beta_3$	$\beta_6$	$\beta_{10}$	$\beta_{12}$	$\beta_{20}$	$\beta_{25}$
02Q	3	$\geq 100$ 99.0	$> 300$ 99.67	$> 1500$ 99.93	$> 2000$ 99.95	$> 5000$ 99.98	INF
05Q	6	12 91.7	$\geq 100$ 99.0	$> 1000$ 99.9	$> 2000$ 99.95	$> 5000$ 99.98	INF
10Q	10	8 87.5	22 95.4	$\geq 100$ 99.0	$\geq 200$ 99.5	$> 5000$ 99.98	INF
20Q	20	-	2 50.0	8 87.5	20 95.0	$\geq 100$ 99.0	$> 200$ 99.5

Element Beta ratio  $\beta_x$   
Element efficiency in percent\*

# 100P Series

## Parts List

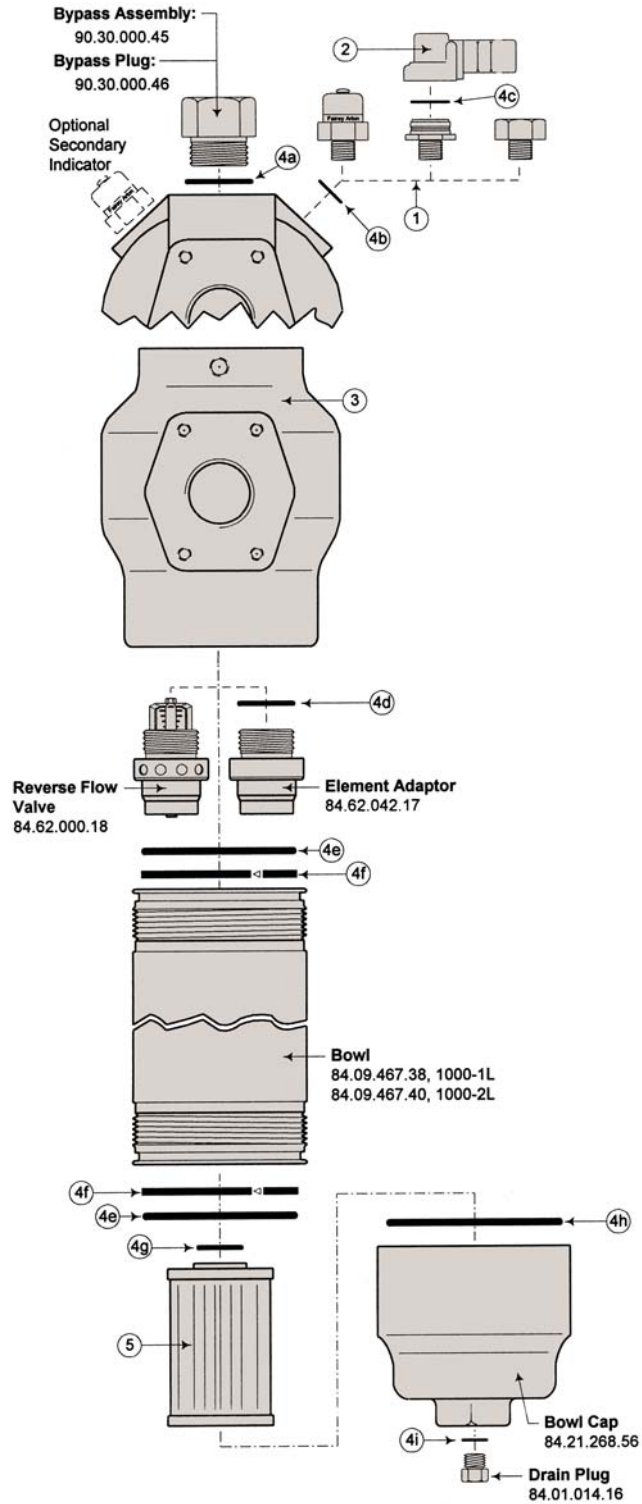

Drawings are for reference only.  
Contact factory for current version.

### 1 Indicators

Visual	Electrical Sub-Assy	Indicator Plug
6N50-2A	90.34.000.24	84.01.066.30

### 2 Electrical Actuator Assembly

Hirschmann Connector		
Code	Part Number	Voltages Available
E2	FF3468	28 VDC, 250 VAC Max.

### 3 Head

Description	Part Number
1000-F, 1-1/2" SAE 6000 PSI Flange, Code 62	84.69.268.20
1000-T, 2" SAE 6000 PSI Flange, Code 62	84.69.268.22

### 4 Seals

Description	Buna-N	Viton
(a) Bypass Assy/Plug Seal*	N93924	V93924
(b) Indicator to Head Seal*	N72019	V72019
(c) Actuator Dust Seal	N72021	
(d) Adaptor to Head Seal*	81.10.150.15	81.10.152.15
(e) Head/Bowl/Cap Seal*	N92346	V92346
(f) Head to Bowl Back-Up Ring	FF3142	
(g) Element Seal	N72141	V72141
(h) Bowl Cap Seal*	81.10.150.86	81.10.152.86
(i) Drain Plug Seal*	N93906	V93906

### 5 Element Kit‡

Disposable All Fluids				
Length	3 µm abs.	6 µm abs.	10 µm abs.	20 µm abs.
2	939064Q	939065Q	939066Q	939067Q
High Collapse Disposable (3000 psid)				
Length	3 µm absolute		15 µm absolute	
2	940741Q		940742Q	

\*Included in Seal Kit: **936063**, Nitrile **8061000013**, Fluorocarbon

†Included in Element Kit

‡To specify seal material, add the following suffix to the part number:

**A** Nitrile **H** Fluorocarbon

### Options (Not Shown)

Part Number	Description
402904	Mounting Bracket, Includes (2) 5/8"-11 x 1-1/4" Hex Flange Bolts

# 100P Series

## How to Order

Select the desired symbol (in the correct position) to construct a model code.

Example:

BOX 1	BOX 2	BOX 3	BOX 4	BOX 5	BOX 6	BOX 7	BOX 8
100P	2	10Q	B	M2	M	F32	1

BOX 1: Filter Series	
Symbol	Description
100P	High Pressure filter

BOX 2: Element Length	
Symbol	Description
2	Double

BOX 3: Media Code	
Symbol	Description
	Standard Element
02Q	Microglass III, 2 micron
05Q	Microglass III, 5 micron
10Q	Microglass III, 10 micron
20Q	Microglass III, 20 micron
	High Collapse Element
02QX	Microglass III, 2 micron
10QX	Microglass III, 10 micron

BOX 4: Seals	
Symbol	Description
B	Nitrile
V	Fluorocarbon

BOX 5: Indicator	
Symbol	Description
M2	Visual differential <sup>2</sup>
E2	Electrical differential <sup>2</sup>

BOX 6: Bypass	
Symbol	Pressure Setting
M	100 PSID (7.0 bar)
X	No bypass <sup>3</sup>

BOX 7: Ports	
Symbol	Description
F24	1-1/2" SAE flange, Code 62
F32	2" SAE flange, Code 62

BOX 8: Options	
Symbol	Description
1	None
3	Reverse flow valve (RFV)
TP	Mounting bracket (including bolts)
3TP	RFV & mounting bracket (including bolts)

### Notes:

1. Filters include the element you select already installed.
2. Indicator setting is 73 psid (5,0 bar).
3. When the no bypass option is selected, a high collapse element must also be selected.