

# MOBILE FLOOR CRANES

2200-4400 lbs.

FC2200

U.S. Patent No. 3,367,512  
Patented 1969 Canada

Adjustable  
Legs

Piston rod  
is ground  
and hard  
chrome  
plated.

Load-lowering valve  
provides controlled descent.

Pump has a  
safety relief valve.

Crane is locked  
in position when  
wheels are lifted.

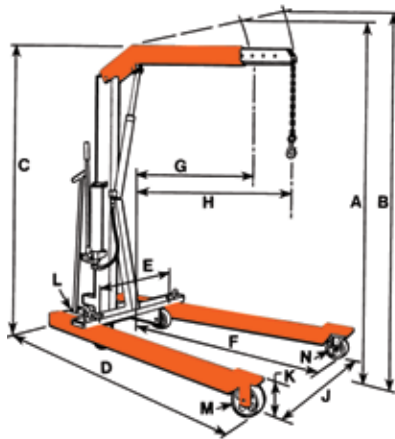

## DIMENSIONS

	FC2200*	FC4400*
Cap., boom ret. (lbs).	2,200	4,400
Cap., boom ext. (lbs).	1,650	3,300
A Max. boom hgt., (ret).	107"	111"
B Max. boom hgt., (ext).	117"	122"
C Overall hgt., boom horiz.	80"	82"
D Overall length	83"	89"
E Min. throat width	24"	25"
F Inside leg length	54"	57 1/2"
G Eff. boom reach (ret).	33"	35 1/2"
H Eff. boom reach (ext).	48"	50 1/2"
J Inside leg width	24" - 36" - 48" (3-position)	26" - 40" - 52 1/2" (3-position)
K Leg height	8"	9 1/2"
L Dolly wheel diameter	5"	5"
M Wheel diameter	6"	8"
N Caster diameter	6"	6"
Floor space, folded	27" x 38"	31" x 42"
Height, folded	79"	86"

2,200 lbs. and 4,400 lbs. capacity  
with space-saving fold-away  
feature



- Adjustable legs spread to clear obstacles, telescoping boom for extra reach. Rugged construction, reliable hydraulics.
- Boom collapses completely and legs fold for compact storage.
- 2-speed hydraulic hand pump provides fast boom travel and precise operator controlled descent.
- Roller bearing wheels and a steering dolly provide ease of mobility. Lifting chain is included.

**No. FC4400** – 4,400 lbs. cap. crane with fold-away feature, adj. leg spread, lifting chain and 2-speed hand pump. Wt., 646 lbs.

