



**W350**  
Max Flow: 50 gpm (189 lpm)



## W350 In-Line Cartridge Filters

**Working Pressures to:** 3000 psi  
21,000 kPa  
210 bar

**Rated Static Burst to:** 7500 psi  
51,700 kPa  
517 bar

**Fatigue Pressure Rating:** 1500 psi  
10,000 kPa  
100 bar

**Flow Range To:** 50 gpm  
189 lpm



### Applications

- High Pressure Circuits
- In-Plant Systems
- Meets HF3 Specification
- Mobile Equipment

## Features

The W350 T-type ported series offers flows up to 50 gpm (190 lpm) with 3 bypass options and conforms to the HF3 automotive standard. Our standard housing drain plug helps relieve system pressure during filter changeouts. DT 4-layer media is offered in a variety of designs. Five different media grades are offered. Donaldson filters core collapse options range from 150 to 3,000 psi (10 to 210 bar). The differential pressure indicator line is designed to work with the wide assortment of bypass valves. Thermal lockout and surge control are two key features incorporated in many of the differential pressure indicators.

- Conforms to HF3 specifications
- High collapse filter available for use with non-bypass applications
- Wide range of indicator options
- Two housing length options for design flexibility
- Head material: cast iron
- Housing material: steel
- Drain plug in housing
- Bleed plug in head

### Beta Rating

- Performance to  $\beta_{<4(c)} = 1000$

### Porting Size Options

- SAE-16 O-ring

### Replacement Filter Lengths

- 4.59" / 116.7mm
- 8.22" / 208.8mm

### Filter Collapse Ratings

- 150 psi / 1034 kPa / 10.3 bar (standard)
- 3000 psi / 20,700 kPa / 206.8 bar (high collapse)

### Standard Bypass Ratings

- 25 psi / 173 kPa / 1.7 bar
- 50 psi / 345 kPa / 3.5 bar
- 90 psi / 621 kPa / 6.2 bar
- No Bypass

### Assembly Weight

- 4.59": 20 lbs / 9.07 kg
- 8.22": 26 lbs / 11.79 kg

### Operating Temperatures

- -20° to 250°F (-29° to 121°C)

## W350 Specification Illustrations

All dimensions are shown in millimeters [inches].

### Assembly - Side View

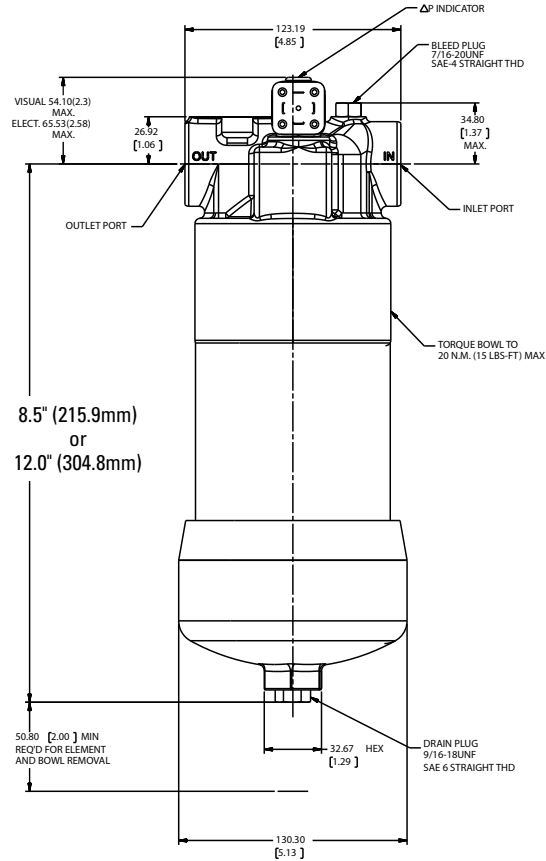

### Head - Top View

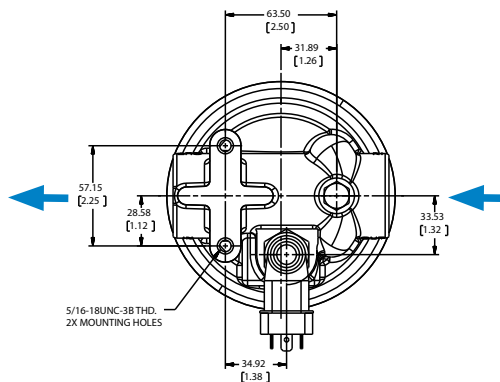



**W350**  
Max Flow: 50 gpm (189 lpm)



## W350 Components

### High-Performance DT Filter Choices

Media Type	$\beta_{x(c)} = 2$ Rating based on ISO 16889	$\beta_{x(c)} = 1000$	Length in mm	Donaldson Part No.	Comments
DT Synteq Synthetic	<4 $\mu\text{m}$	4.59	117	P566204	DT-9600-4-2UM
	5 $\mu\text{m}$	4.59	117	P566205	DT-9600-4-5UM
	8 $\mu\text{m}$	4.59	117	P566206	DT-9600-4-8UM
	12 $\mu\text{m}$	4.59	117	P566207	DT-9600-4-14UM
	23 $\mu\text{m}$	4.59	117	P566208	DT-9600-4-25UM
	5 $\mu\text{m}$	4.56	116	P566364	DT-9601-4-5UM, High collapse
	12 $\mu\text{m}$	4.56	116	P566365	DT-9601-4-14UM, High collapse
	<4 $\mu\text{m}$	8.22	209	P566209	DT-9600-8-2UM
	5 $\mu\text{m}$	8.22	209	P566210	DT-9600-8-5UM
	8 $\mu\text{m}$	8.22	209	P566211	DT-9600-8-8UM
	12 $\mu\text{m}$	8.22	209	P566212	DT-9600-8-14UM
	23 $\mu\text{m}$	8.22	209	P566213	DT-9600-8-25UM
	5 $\mu\text{m}$	8.19	208	P566366	DT-9601-8-5UM, High collapse
	12 $\mu\text{m}$	8.19	208	P566367	DT-9601-8-14UM, High collapse
	<4 $\mu\text{m}$	8.22	209	P567875	DX2-9600-8-2UM
5 $\mu\text{m}$	8.22	209	P565122	DX2-9600-8-5UM	
8 $\mu\text{m}$	8.22	209	P565123	DX2-9600-8-8UM	
14 $\mu\text{m}$	8.22	209	P564936	DX2-9600-8-14UM	
Water Absorbing	10 $\mu\text{m}$	8	209	P569528	Absorbs 130 ml water @ 25 psid



#### Filter Notes

All Donaldson DT and DX2 filters utilize glass fiber media with an epoxy-based resin system for the ultimate in chemical compatibility. All Donaldson DT and DX2 filters are potted with epoxy-based adhesives. Standard collapse DT designs are double wire-backed using epoxy-coated steel mesh for maximum pleat support and dirt capacity. High collapse designs are double wire-backed using stainless steel mesh. High collapse designs are also potted into machined aluminum endcaps for greater filter integrity in critical applications. Viton® seals are standard on all Donaldson DT and DX2 filters. Viton® is a registered trademark of E. I. DuPont de Nemours and Company. DX2 filters utilize nylon mesh for pleat support.

## Performance Data

**W350 4" DT Filter Only**  
DT-9600-4, 4"/102mm

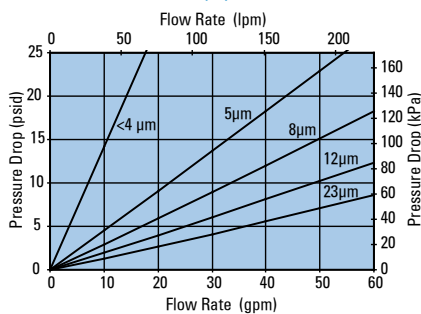

**W350 4" DT Filter Only**  
DT-9601-4, 4"/102mm

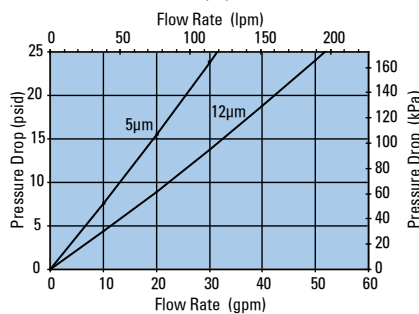

**W350 Housing Only**

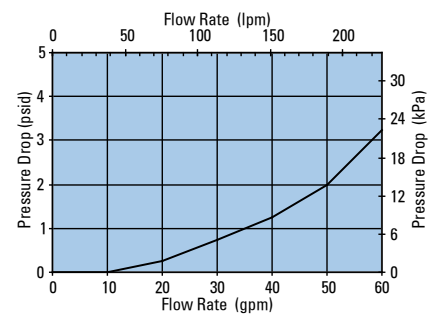

**W350 8" DT Filter Only**  
DT-9600-8, 8"/203mm

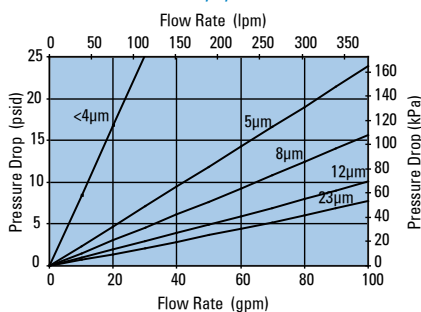

**W350 8" DT Filter Only**  
DT-9601-8, 8"/203mm

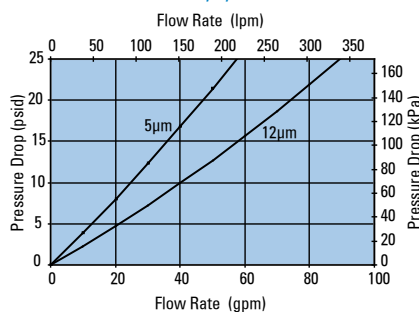

**W350 8" DT Filter Only**  
DX2-9600-8, 8"/203mm

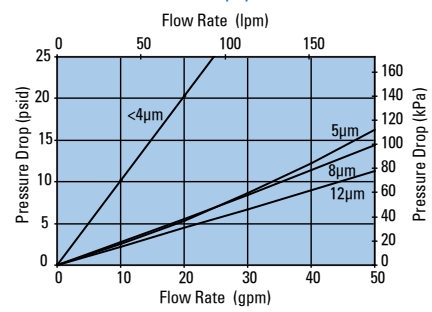



## Head Assembly Choices

Port Size	Bypass Rating	Seal Material Material	Indicator Style & Location	Donaldson Part No.
SAE-16 O-ring	50 psi / 3.45 bar	Buna-N	Port Machined & Plugged	P574245
SAE-16 O-ring	90 psi / 6.21 bar	Buna-N	Port Machined & Plugged	P574246
SAE-16 O-ring	None	Buna-N	Port Machined & Plugged	P574247

## Housing Choices

Housing Length	Seal Material	Donaldson Part No.
4" (101.6mm)	Buna-N	X011556
8" (203.2mm)	Buna-N	X011558

## Indicator Choices

Indicator Pressure Setting	Connector Style	Seal Material	Donaldson Part No.	Thermal Lockout	Surge Control	Reset
<b>Visual Pop-up Models</b>						
35 psi / 241 kPa	NA	Buna-N	P572347	No	No	Auto
35 psi / 241 kPa	NA	Buna-N	P572348	Yes	Yes	Manual
35 psi / 241 kPa	NA	Viton	P567456	Yes	Yes	Manual
70 psi / 482 kPa	NA	Buna-N	P572319	Yes	Yes	Manual
70 psi / 482 kPa	NA	Viton	P567457	Yes	Yes	Manual
100 psi / 690 kPa	NA	Buna-N	P572353	Yes	Yes	Manual
100 psi / 690 kPa	NA	Viton	P572354	Yes	Yes	Manual
<b>Electrical / Visual Models</b>						
35 psi / 241 kPa	Hirschman	Buna-N	P572327	No	No	Auto
35 psi / 241 kPa	Brad Harrison	Buna-N	P572329	No	No	Auto
35 psi / 241 kPa	Hirschman	Buna-N	P572384	Yes	Yes	Manual
35 psi / 241 kPa	Hirschman	Viton	P567458	Yes	Yes	Manual
35 psi / 241 kPa	Brad Harrison	Buna-N	P572385	Yes	Yes	Manual
35 psi / 241 kPa	3 wire flying leads	Buna-N	P572349	No	No	Auto
70 psi / 482 kPa	Hirschman	Buna-N	P572320	Yes	Yes	Manual
70 psi / 482 kPa	Brad Harrison	Buna-N	P567459	Yes	Yes	Manual
70 psi / 482 kPa	Hirschman	Buna-N	P572373	Yes	No	Manual
70 psi / 482 kPa	Hirschman	Viton	P569639	Yes	No	Manual
100 psi / 690 kPa	Hirschman	Buna-N	P572387	Yes	Yes	Manual
<b>Electrical Models</b>						
35 psi / 241 kPa	Hirschman	Buna-N	P572359	No	No	Auto
35 psi / 241 kPa	Brad Harrison	Buna-N	P572361	No	No	Auto
70 psi / 482 kPa	Hirschman	Buna-N	P572369	No	No	Auto

## Head/Bowl/Housing Seal Kits

Donaldson Part No.	Material
X011170	Buna
X011171	Viton