

# AES Series - Two-Way Block Body Flange Head

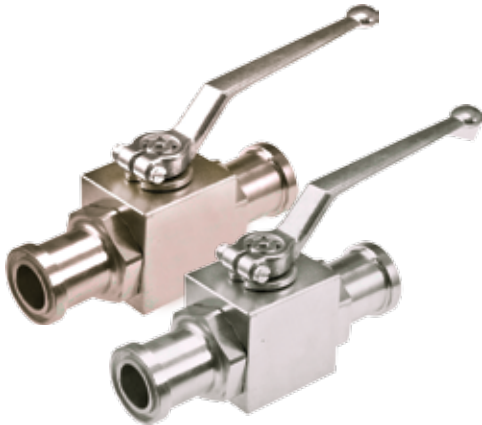

- Carbon Steel with Zinc Chromate Plating (RoHS Compliant)
- 316 stainless steel available from stock
- POM seats & Buna O-rings standard on carbon steel valves
- Optional seal materials available for extreme temperature applications & fluid compatibility (Consult Factory)

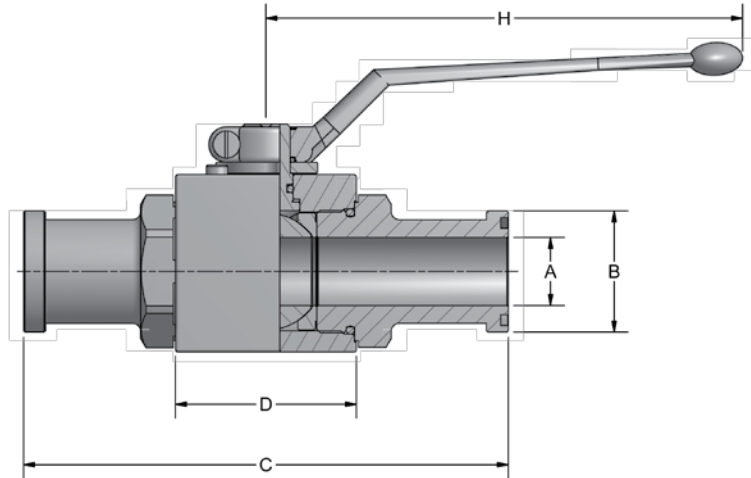
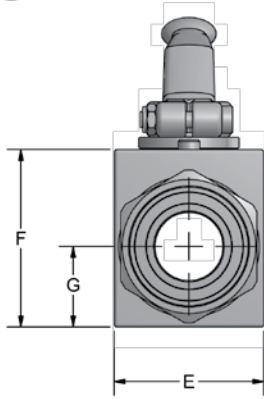

Standard handles supplied are:  
Refer to page 43 for details.

#8                    C1010ZB  
#12 & #16        C1200ZB

AES SERIES - CODE 61										
SERIES	PSI MAX	A BORE	B	C	D	E	F	G	H	WEIGHT
AES3#8	5000	.51	1.19	5.96	1.91	1.46	1.70	.71	4.33	2.1 LBS
AES3#12	5000	.79	1.50	6.38	2.46	1.77	2.17	.92	7.09	3.8 LBS
AES3#16	5000	.98	1.75	7.00	2.62	2.17	2.56	1.16	7.09	5.7 LBS

AES SERIES - CODE 62										
SERIES	PSI MAX	A BORE	B	C	D	E	F	G	H	WEIGHT
AES6#8	6000	.51	1.24	5.96	1.91	1.46	1.70	.71	4.33	2.1 LBS
AES6#12	6000	.79	1.63	6.85	2.46	1.77	2.17	.92	7.09	4.0 LBS
AES6#16	5000	.98	1.88	7.80	2.62	2.17	2.56	1.16	7.09	6.1 LBS



# AES Series - Two-Way Block Body Flange Head

## Model Code Breakdown

AES3 #16 - 1 1 D B \_

**VALVE SERIES**

AES3	Code 61
AES6	Code 62

**CONNECTION SIZE**

**BODY & ADAPTER MATERIAL**

1	Carbon Steel
2	316 Stainless Steel

**BALL & STEM MATERIAL**

1	Carbon Steel
2	316 Stainless Steel

**LOCKING KIT OR OPTIONAL HANDLE CODE**  
(See pages 42 & 43)

**ADAPTER & STEM SEALS**

B	Buna- Standard
V	Viton (Std on S/S)

**BALL & STEM SEATS**

D	POM- Standard
P	PEEK
N	PA612

Please consult your system's seal manufacturer for recommendation of seal selection, as Anchor Fluid Power does not accept responsibility for seal selection.

### MAXIMUM & MINIMUM WORKING TEMPERATURES FOR SEAL MATERIALS

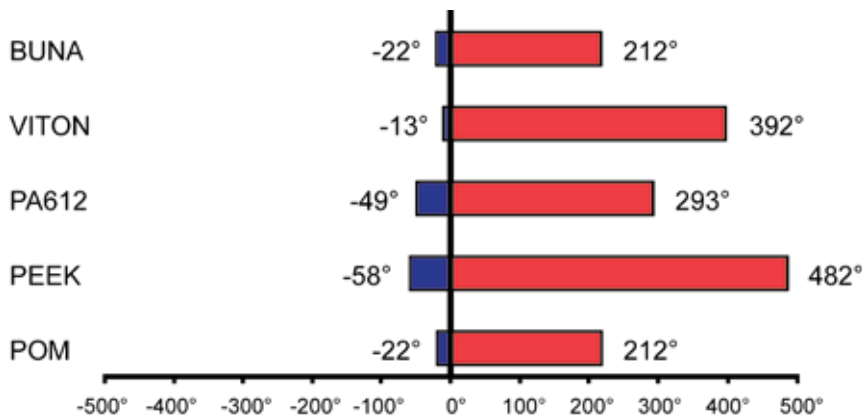

All temperatures are in degrees Fahrenheit.