

ABS Series - Two-Way Round Body Flange Head

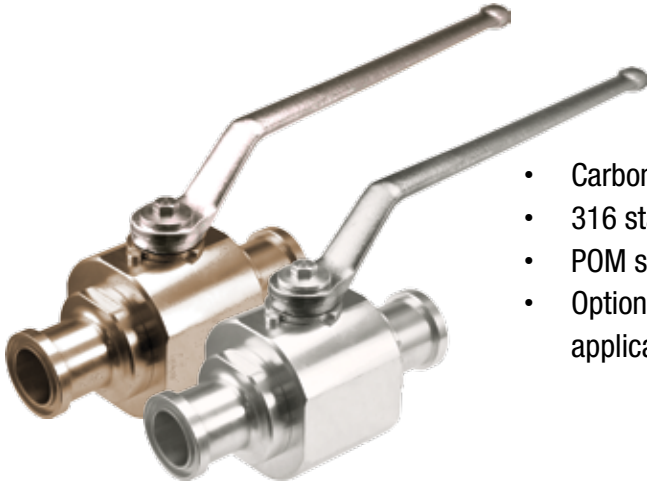

- Carbon Steel with Zinc Chromate Plating (RoHS Compliant)
- 316 stainless steel available from stock
- POM seats & Buna O-rings standard on carbon steel valves
- Optional seal materials available for extreme temperature applications & fluid compatibility (Consult Factory)

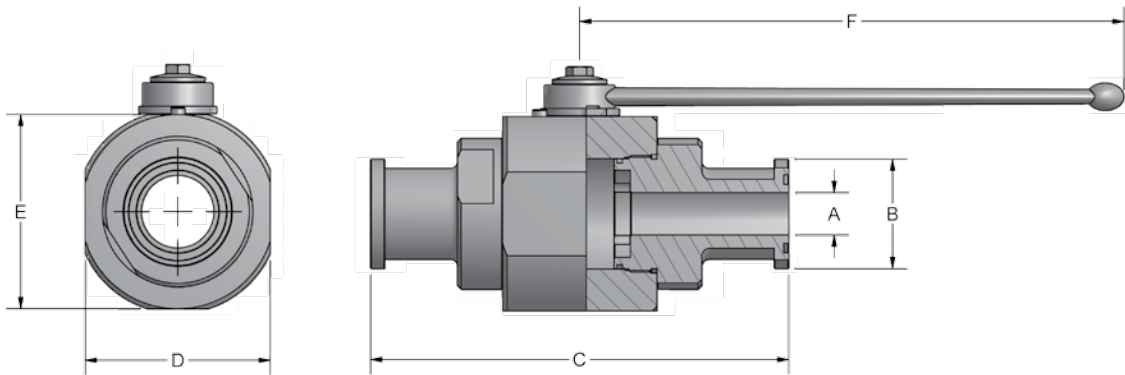

Standard handle supplied is C92501Z-SW17. Refer to page 43 for details.

ABS SERIES - CODE 61								
SERIES	PSI MAX	A BORE	B	C	D	E	F	WEIGHT
ABS3#20	4000	1.26	2.00	7.50	3.46	3.66	11.81	12.0 LBS
ABS3#24	3000	1.57	2.37	9.08	4.02	4.21	11.81	18.2 LBS
ABS3#32	3000	1.89	2.81	9.13	4.65	4.49	11.81	21.7 LBS

ABS SERIES - CODE 62								
SERIES	PSI MAX	A BORE	B	C	D	E	F	WEIGHT
ABS6#20	5000	1.26	2.13	8.78	3.46	3.66	11.81	12.8 LBS
ABS6#24	5000	1.57	2.50	11.06	4.02	4.21	11.81	18.2 LBS
ABS6#32	5000	1.89	3.13	12.44	4.65	4.49	11.81	26.0 LBS



ABS Series - Two-Way Round Body Flange Head

Model Code Breakdown

ABS3 #32 - 1 1 D B _

VALVE SERIES

ABS3	Code 61
ABS6	Code 62

CONNECTION SIZE

BODY & ADAPTER MATERIAL

1	Carbon Steel
2	316 Stainless Steel

BALL & STEM MATERIAL

1	Carbon Steel
2	316 Stainless Steel

**LOCKING KIT OR
OPTIONAL HANDLE CODE**
(See pages 42 & 43)

ADAPTER & STEM SEALS

B	Buna- Standard
V	Viton (Std on S/S)

BALL & STEM SEATS

D	POM- Standard
P	PEEK
N	PA612

Please consult your system's seal manufacturer for recommendation of seal selection, as Anchor Fluid Power does not accept responsibility for seal selection.

MAXIMUM & MINIMUM WORKING TEMPERATURES FOR SEAL MATERIALS

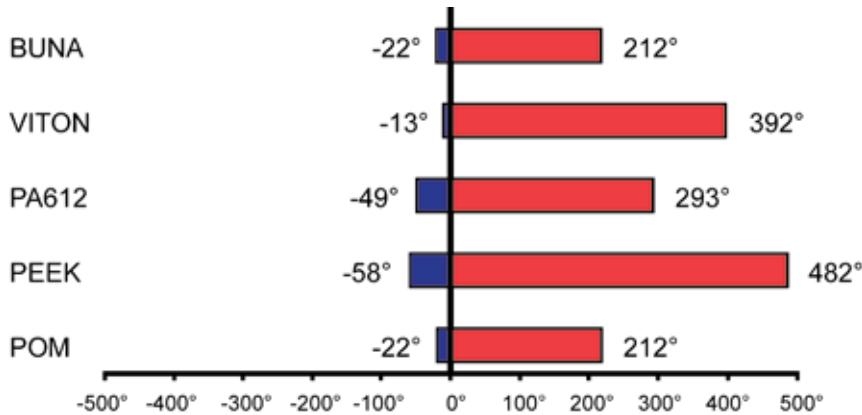

All temperatures are in degrees Fahrenheit.