

AEF Series - Two-Way Block Body Flat Face

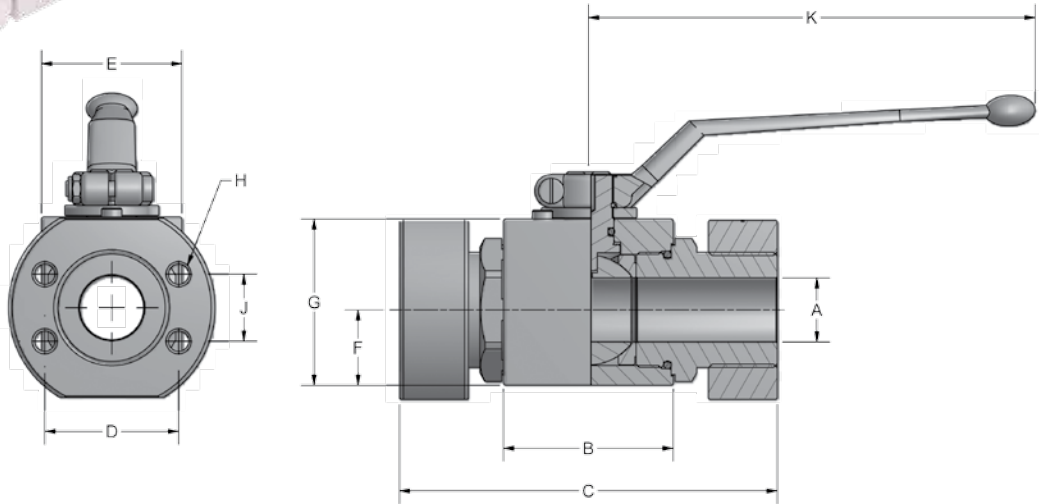

- Carbon Steel with Zinc Chromate Plating (RoHS Compliant)
- 316 stainless steel available from stock
- POM seats & Buna O-rings standard on carbon steel valves
- Optional seal materials available for extreme temperature applications & fluid compatibility (Consult Factory)



Standard handles supplied are:
Refer to page 43 for details.

- | | |
|-----------|---------|
| #8 | C1010ZB |
| #12 - #16 | C1200ZB |

AEF SERIES - CODE 61												
SERIES	PSI MAX	A BORE	B	C	D	E	F	G	H UNC-2B	J	K	WEIGHT
AEF3#8	5000	.51	1.91	4.72	1.50	1.46	.71	1.69	5/16-18	.69	4.33	3.3 LBS
AEF3#12	5000	.79	2.46	5.35	1.87	1.77	.92	2.17	3/8-16	.87	7.09	5.7 LBS
AEF3#16	5000	.98	2.62	5.83	2.06	2.17	1.16	2.56	3/8-16	1.03	7.09	8.6 LBS

AEF SERIES - CODE 62												
SERIES	PSI MAX	A BORE	B	C	D	E	F	G	H UNC-2B	J	K	WEIGHT
AEF6#8	6000	.51	1.91	4.72	1.59	1.46	.71	1.69	5/16-18	.72	4.33	3.3 LBS
AEF6#12	6000	.79	2.46	5.35	2.00	1.77	.92	2.17	3/8-16	.94	7.09	5.7 LBS
AEF6#16	5000	.98	2.62	5.83	2.25	2.17	1.16	2.56	7/16-14	1.09	7.09	8.6 LBS



AEF Series - Two-Way Block Body Flat Face

Model Code Breakdown

AEF3 #16 - 1 1 D B _

VALVE SERIES

AEF3	Code 61
AEF6	Code 62

CONNECTION SIZE

BODY & ADAPTER MATERIAL

1	Carbon Steel
2	316 Stainless Steel

BALL & STEM MATERIAL

1	Carbon Steel
2	316 Stainless Steel

**LOCKING KIT OR
OPTIONAL HANDLE CODE**
(See pages 42 & 43)

ADAPTER & STEM SEALS

B	Buna- Standard
V	Viton (Std on S/S)

BALL & STEM SEATS

D	POM- Standard
P	PEEK
N	PA612

Please consult your system's seal manufacturer for recommendation of seal selection, as Anchor Fluid Power does not accept responsibility for seal selection.

MAXIMUM & MINIMUM WORKING TEMPERATURES FOR SEAL MATERIALS

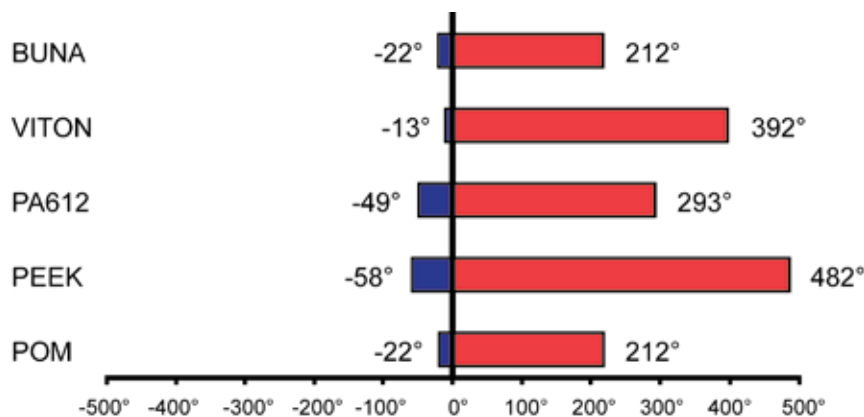

All temperatures are in degrees Fahrenheit.