

# HYDRAULIC BALL VALVES

## LV2B Series - 1000 WOG Stainless Steel

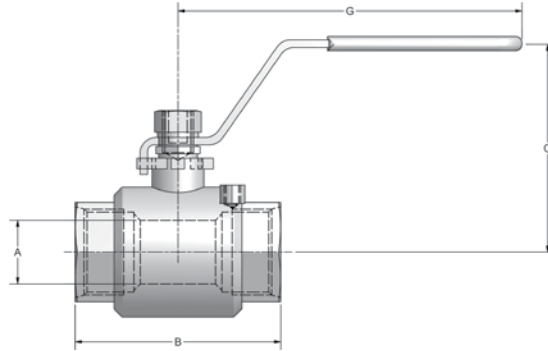

- All stainless steel construction
- Locking handles standard
- Ideal for suction, pressure and return lines
- Available in NPT & SAE threads
- Mounting holes standard on SAE #16 - #64

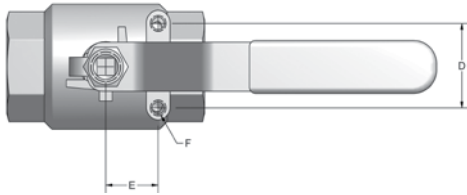

LV2B SERIES - NPT							
SIZE	A	B	C	D	E	F UNC	G
1/4"	.36	2.13	2.13	1.12	.49	N/A	4.33
3/8"	.50	2.13	2.17	1.12	.49	N/A	4.33
1/2"	.59	2.24	2.28	1.12	.49	N/A	4.53
3/4"	.79	2.68	2.40	1.12	.49	N/A	4.53
1"	.98	3.15	3.03	1.38	.91	N/A	5.04
1-1/4"	1.26	3.58	3.19	1.48	1.00	N/A	5.04
1-1/2"	1.50	4.06	3.54	1.48	1.00	N/A	6.10
2"	1.97	4.88	4.25	1.50	1.00	N/A	6.10
2-1/2"	2.56	6.30	5.20	N/A	N/A	N/A	9.06
3"	3.15	7.28	5.71	N/A	N/A	N/A	9.06

LV2B SERIES - SAE							
SIZE	A	B	C	D	E	F UNC	G
1/4"	.35	2.40	2.13	1.12	.49	N/A	4.33
3/8"	.47	2.40	2.17	1.12	.49	N/A	4.33
1/2"	.59	2.52	2.28	1.12	.49	N/A	4.53
3/4"	.79	3.23	2.40	1.12	.49	N/A	4.53
1"	.98	3.62	3.03	1.38	.91	1/4-20	5.04
1-1/4"	1.26	3.96	3.19	1.48	1.00	1/4-20	5.04
1-1/2"	1.50	4.23	3.54	1.48	1.00	1/4-20	6.10
2"	1.97	4.90	4.25	1.50	1.00	1/4-20	6.10
2 1/2"	2.56	6.30	5.20	2.25	1.18	1/4-20	9.06
3"	3.15	7.28	5.71	2.76	1.18	1/4-20	9.06
*4"	3.93	8.80	7.11	2.76	1.18	1/4-20	13.00

MODEL CODE:

LV2B N 1/2" -2T

THREAD TYPE (N-NPT; S-SAE)

THREAD SIZE (EX. N1/2"; S#8)

COMPONENT MATERIALS		
COMPONENT	MATERIAL	QTY
VALVE BODY	ASTM A351 GR CF8M	1
TAILPIECE	ASTM A351 GR CF8M	1
BALL	ASTM A351 GR CF8M	1
STEM	316	1
BALL SEAT	PTFE	2
STEM SEAT	PTFE	1
STEM PACKING	PTFE	1
STEM GLAND	304	1
HANDLE	304	1
STEM LOCK WASHER	304	1
STEM NUT	304	1
HANDLE SLEEVE	VINYL	1
LOCK	304	1

PRESSURE-TEMPERATURE RATING

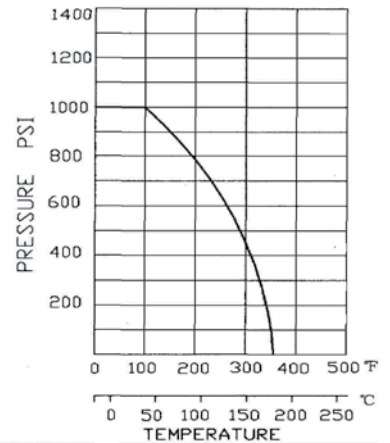

\* 4"SAE - 500 PSI max for LV2BS#64-2T-MH

\*\* For WOG Accessories refer to pages 67



866-FLANGES | 513.527.4444 | Fax 513.527.4449

sales@anchorfluidpower.com | anchorfluidpower.com