

PORTABLE HOSE REELS **CM & DM SERIES**

COXREELS® CM Series “Caddy Mount” and DM Series “Dolly Mount” hand crank hose reels offer lightweight, compact portability for long lengths of hose. Eliminate the task of manually coiling and uncoiling hose and easily transport it to the job site on wheels. High pressure applications are no problem with a 4,000 PSI rating. Also, a 4’ inlet hose with 3/4” female fitting and male garden adaptor is available with this series for use with garden hose. See options below.

CM SERIES MODELS - CADDY MOUNT

LESS HOSE									
MODEL	STANDARD CAPACITY			OPTIONAL CAPACITY Reducer Required			PSI	APRX LBS.	SIZE INDEX
	I.D.	O.D.	FT.	I.D.	O.D.	FT.			
112-3-100-CM	3/8"	5/8"	100	1/4"	1/2"	150	4,000	18	1
112-3-150-CM	3/8"	5/8"	150	1/4"	1/2"	225	4,000	22	2
117-4-225-CM	1/2"	7/8"	225	3/8"	3/4"	315	4,000	28	3



DM SERIES MODELS - DOLLY MOUNT

LESS HOSE									
MODEL	STANDARD CAPACITY			OPTIONAL CAPACITY Reducer Required			PSI	APRX LBS.	SIZE INDEX
	I.D.	O.D.	FT.	I.D.	O.D.	FT.			
117-3-200-DM	3/8"	5/8"	200	1/4"	1/2"	350	4,000	37	4
117-4-225-DM	1/2"	7/8"	225	3/8"	3/4"	315	4,000	39	5

CM & DM SERIES :: REEL SPECIFICATIONS

SWIVEL

- External fluid path with machined from solid brass 90° full-flow NPT swivel inlet
- Up to 4,000 PSI working pressure
- Swivel Seals: NITRILE

CM SERIES DESIGN & STRUCTURE

- High quality one piece 1” steel tube frame structure
- Hose Control bar prevents hose from slipping off the discs
- Adjustable tension brake to prevent “free-wheeling”
- Base has holes for temporary or permanent installation

DM SERIES DESIGN & STRUCTURE

- High quality three piece 1-1/4” steel tube frame structure
- Solid 8” rubber tires for easy transport
- Rubber front feet prevent reel from slipping forward
- Removable handle allow for compact storage
- Adjustable tension brake to prevent “free-wheeling”

RETRACTION

- Direct hand crank rewind

SIGNATURE FEATURES

- Professional grade heavy duty steel construction
- Durable proprietary CPC™ powder coat process
- Rolled edges & ribbed discs provide strength & safety
- Leading 2-year manufacturer’s limited warranty
- Made in the U.S.A. - Sold & Supported Worldwide

POSSIBLE FIELDS OF APPLICATION

- Water Supply
- Washdown
- Pressure Washing
- Agricultural Spraying
- Chemical Fluid Transfer
- Ground Maintenance
- Restaurants
- Construction Sites
- General Landscape/Turf Care
- Home Gardening

ACCESSORIZE YOUR REEL :: PG 50

- Mounting Brackets
- Assorted Reel Accessories

• Hoses



REEL DIMENSIONS

Technical Data Sheets Available On Website

SIZE INDEX	W	H	L	X	Y	M	N	Ø	Dw
1	18 1/2"	14 3/4"	13 1/8"	11 1/2"	10 5/8"	10 1/2"	5 1/4"	5 1/2"	8"
2	23"	14 3/4"	13 1/8"	16"	10 1/2"	10 1/2"	5 1/4"	5 1/2"	12 1/2"
3	23"	18 1/2"	18"	16"	12 5/8"	10 1/2"	5 1/4"	5 1/2"	12 1/2"
4	19"	36 1/4"	21"	12"	17 1/2"	-	-	5 1/2"	8"
5	23 1/2"	36 1/4"	21"	16 1/2"	17 1/2"	-	-	5 1/2"	12 1/2"

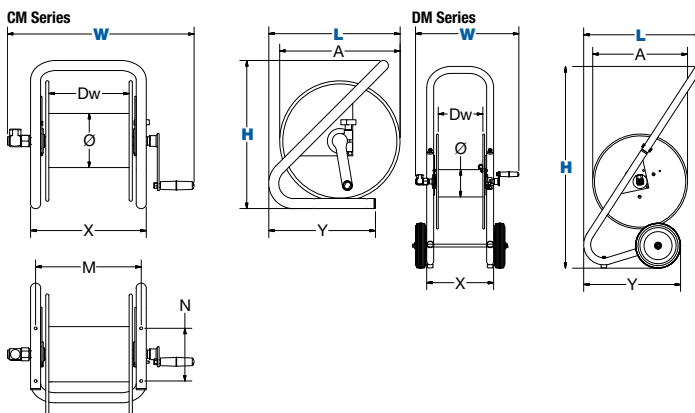

COXREELS® 1/2" HOSE ACCESSORY

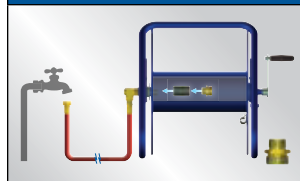

Garden Hose Kit

You are able to connect any hose to a reel with 1/2” plumbing. You will be able to use any garden hose for everything from watering plants to washing your car. Kit includes: NPT to garden hose adaptor & adaptor hose **#15717**