

AE2 Series - Two-Way Block Body Threaded

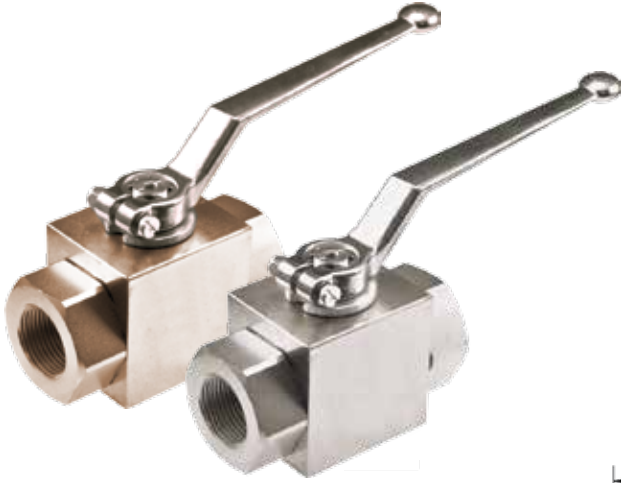

- Carbon Steel with Zinc Chromate Plating (RoHS Compliant)
- 316 stainless steel available from stock
- Unrestricted bore up to 1" size
- POM seats & Buna O-rings standard on carbon steel valves
- Optional seal materials available for extreme temperature applications & fluid compatibility (Consult Factory)

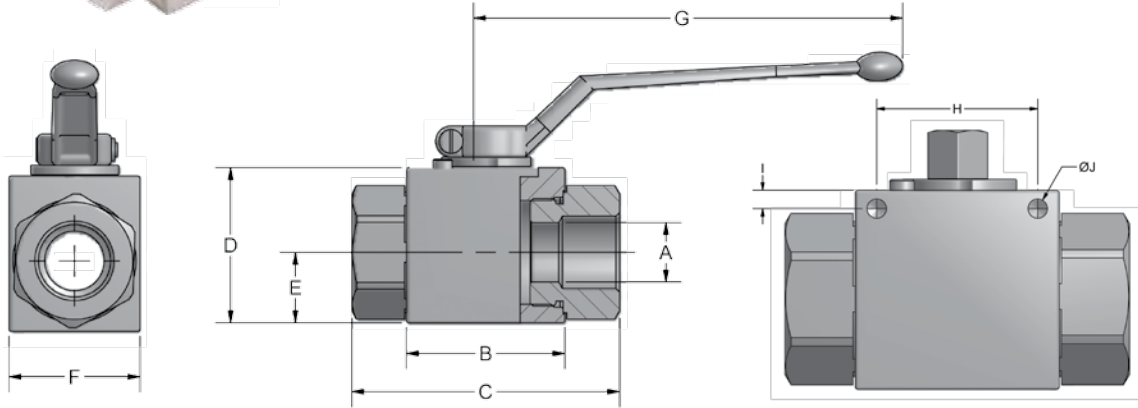

Standard handles supplied are:
Refer to page 43 for details.

1/8" - 1/2"
3/4" - 1 1/2"

C1010ZB
C1200ZB

Optional Mounting Holes

AE2 SERIES FULL BORE

SERIES		PSI MAX	A BORE	B	C	D		E	F		G	H	I	J	WEIGHT
NPT	SAE					CARBON	STAINLESS		CARBON	STAINLESS					
AE2 N1/8	N/A	7250	.16	1.67	2.80	1.38	C/F	.57	1.18	C/F	4.33	C/F	C/F	C/F	1.1 LBS
AE2 N1/4	AE2 S#4	7250	.24	1.67	2.80	1.38	1.38	.57	1.18	1.38	4.33	1.34	.18	.21	1.1 LBS
AE2 N3/8	AE2 S#6	7250	.39	1.75	2.87	1.57	1.57	.69	1.38	1.57	4.33	1.34	.18	.21	1.4 LBS
AE2 N1/2	AE2 S#8	7250	.51	1.90	3.27	1.69	1.77	.71	1.46	1.77	4.33	1.42	.20	.21	1.7 LBS
AE2 N3/4	AE2 S#12	5800	.79	2.46	3.74	2.17	2.17	.92	1.77	2.17	7.09	1.97	.24	.25	3.3 LBS
AE2 N1	AE2 S#16	5075	.98	2.62	4.41	2.56	2.56	1.16	2.17	2.56	7.09	1.97	.24	.25	5.0 LBS

AE2 SERIES REDUCED BORE

SERIES		PSI MAX	A BORE	B	C	D		E	F		G	H	I	J	WEIGHT
NPT	SAE					CARBON	STAINLESS		CARBON	STAINLESS					
AE2 N1-1/4R	AE2 S#20R	5075	.98	2.62	4.72	2.56	2.56	1.16	2.17	2.56	7.09	C/F	C/F	C/F	5.2 LBS
AE2 N1-1/2R	AE2 S#24R	5075	.98	2.62	4.88	2.56	2.56	1.16	2.17	2.56	7.09	C/F	C/F	C/F	5.5 LBS



AE2 Series - Two-Way Block Body Threaded

Model Code Breakdown

AE2 N1/2 _ - 1 1 D B _ _ _

VALVE SERIES

CONNECTION TYPE/SIZE

N	NPT Pipe Thread
S	SAE Straight Thread
B	BSPP Thread

BORE RESTRICTION

blank	Unrestricted Bore
R	Restricted Bore

BODY & ADAPTER MATERIAL

1	Carbon Steel
2	316 Stainless Steel

BALL & STEM MATERIAL

1	Carbon Steel
2	316 Stainless Steel

OPTIONAL MOUNTING HOLE

MH	Mounting Holes
----	----------------

**LOCKING KIT OR
OPTIONAL HANDLE CODE**
(See pages 42 & 43)

ADAPTER & STEM SEALS

B	Buna- Standard
V	Viton (Std on S/S)

BALL & STEM SEATS

D	POM- Standard
P	PEEK
N	PA612

Please consult your system's seal manufacturer for recommendation of seal selection, as Anchor Fluid Power does not accept responsibility for seal selection.

MAXIMUM & MINIMUM WORKING TEMPERATURES FOR SEAL MATERIALS

