

F12 Large Frame Fixed Displacement Bent-Axis Pumps



F12 is a high performance, bent axis, fixed displacement heavy-duty pump series. They can be used in numerous applications where high efficiency, high drive speeds, high pressure and indirect drives are desired. The F12 will provide high output flows in a very compact package.

Pump Performance Data

Model Series	Displacement in ³ /rev (cc/rev)	Continuous Pressure PSI (BAR)	Rated Speed RPM	Flow GPM (LPM)
F12-030	1.83 (30.0)	6000 (420)	3150	23 (87.1)
F12-040	2.44 (40.0)	6000 (420)	2870	28 (106.0)
F12-060	3.64 (59.6)	6000 (420)	2500	37 (140.1)
F12-080	4.91 (80.4)	6000 (420)	2300	46 (174.1)
F12-090	5.68 (93.0)	6000 (420)	2300	53.5 (202.5)
F12-110	6.72 (110.1)	6000 (420)	2290	63 (238.5)
F12-125	7.63 (125.0)	6000 (420)	2290	72 (272.5)
F12-150	9.15 (150.0)	5000 (350)	3200	103 (389.9)
F12-250	14.77 (242.0)	5000 (350)	2700	154 (583.0)

Markets

Applications

Forestry	Saw Drives, Feller Bunchers, Skidder, Forwarder, Cranes, Mowers / Cutters
Industrial	Aircraft Test Stands
Marine	Deck Cranes, Constant Tension Winches, Hatch Covers
Oil & Gas	Nitrogen Pumpers, Frac Trucks
Construction	Skid Steer, Off-Highway Trucks, Fan Drives, Cranes, Dust Collector, Excavator
Mining	Drill Rigs, Top Drives, Loaders, Subsurface Loaders, Tunneling Equipment
Material Handling	Conveyor Drives, Truck Mounted Cranes, Mixers
Recycling	Shredders, Vacuum Truck Systems
Military	Fan Drives

F12 Large Frame Fixed Displacement Bent-Axis Pumps

Performance Characteristics

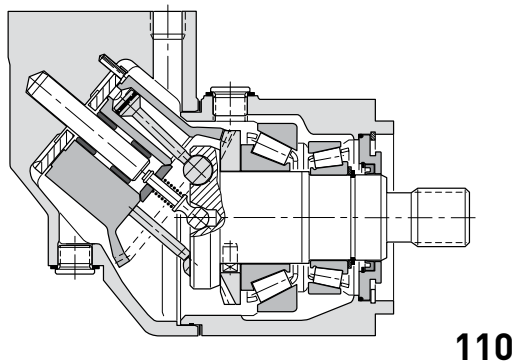
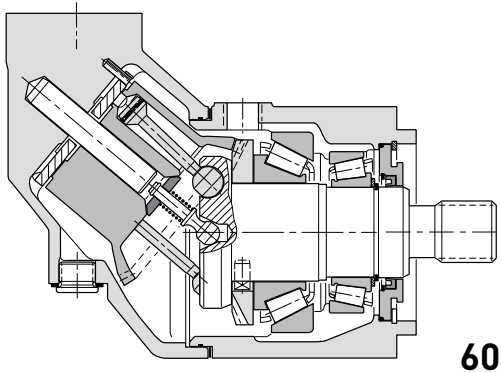

F12 Series Overall Efficiency

Pump - 420 bar (6092 PSI)

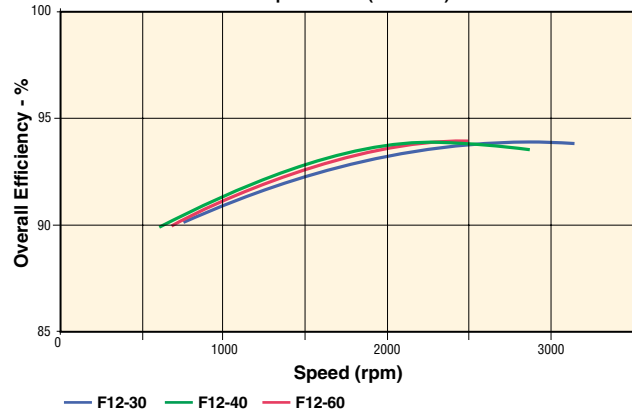

F12 Series Overall Efficiency

Pump - 420 bar (6092 PSI)

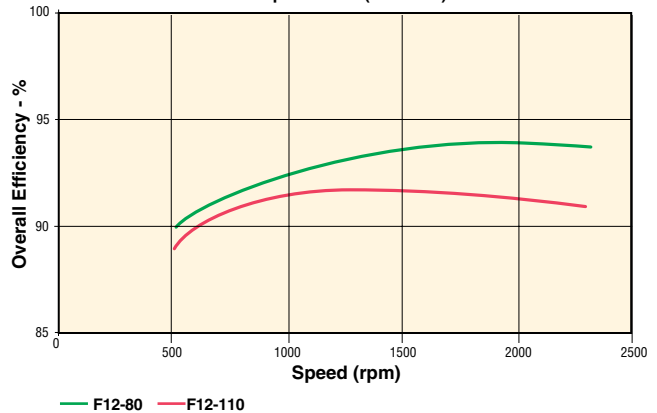

F12 Series Overall Efficiency

Motor - 250 bar (3625 PSI)

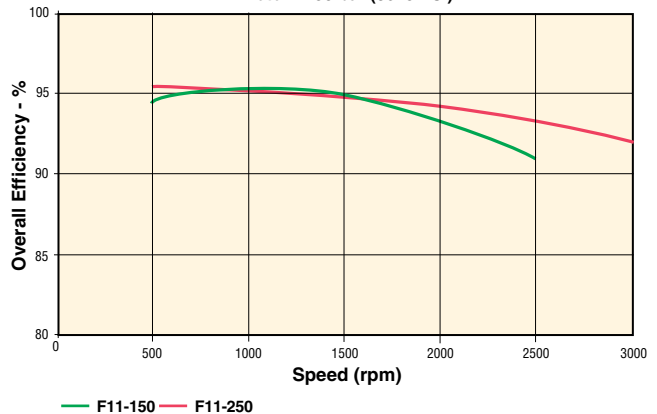

Benefits/Features

- Intermittent operating pressures to 7000 PSI (482.6 BAR)
- Compact, lightweight pump with high power to weight ratio
- Laminated piston ring provides low internal leakage and thermal shock resistance
- F12 Series have very few moving parts providing long life and service friendly design
- Heavy duty roller bearings provide indirect drive capability

F12 Large Frame Fixed Displacement Bent-Axis Pumps

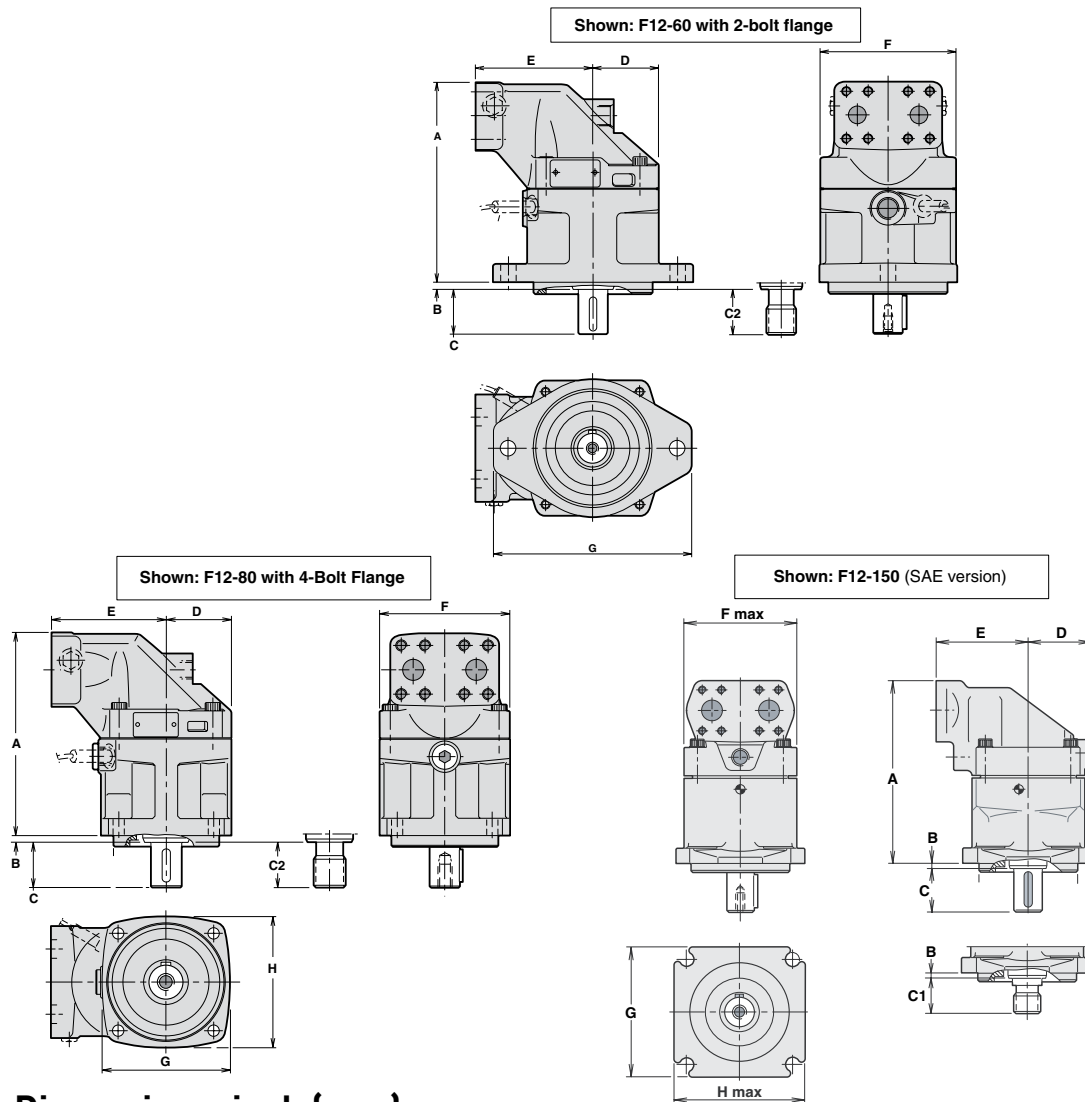

Dimensions, inch (mm)

Series 2-BOLT	A	B	C	C2	D	E	F	G
F12-30	7.46 (189.5)	0.31 (7.9)	1.5 (38.1)	1.3 (33.0)	2.32 (58.9)	3.94 (100.1)	4.80 (121.9)	6.93 (176.0)
F12-40	7.76 (197.1)	0.31 (7.9)	1.89 (48.0)	1.89 (48.0)	2.56 (64.0)	4.33 (110.0)	5.28 (134.1)	8.46 (214.9)
F12-60	8.43 (214.1)	0.31 (7.9)	1.89 (48.0)	1.89 (48.0)	2.76 (70.1)	4.92 (125.0)	5.67 (144.0)	8.46 (214.9)

Series 4-BOLT	A	B	C	C2	D	E	F	G	H
F12-30	7.46 (189.5)	0.31 (7.9)	1.50 (38.1)	1.30 (33.0)	2.32 (58.9)	3.94 (100.1)	4.80 (121.9)	4.65 (118.1)	4.65 (118.1)
F12-40	7.76 (197.1)	0.31 (7.9)	1.89 (48.0)	1.89 (48.0)	2.56 (65.0)	4.33 (110.0)	5.28 (134.1)	5.83 (148.1)	5.67 (144.0)
F12-60	8.43 (214.1)	0.31 (7.9)	1.89 (48.0)	1.89 (48.0)	2.76 (70.1)	4.92 (125.0)	5.67 (144.0)	5.83 (148.1)	5.67 (144.0)
F12-80	9.45 (240.0)	0.31 (7.9)	2.13 (54.1)	2.13 (54.1)	3.05 (77.5)	5.31 (134.9)	6.10 (154.9)	6.10 (154.9)	6.10 (154.9)
F12-110	10.39 (263.9)	0.31 (7.9)	2.64 (67.1)	2.63 (66.8)	3.35 (85.1)	5.71 (145.0)	6.69 (169.9)	8.03 (204.0)	7.87 (199.9)
F12-150	13.98 (355.1)	.31 (7.9)	2.63 (66.8)	2.63 (66.8)	4.65 (118.1)	6.77 (172.0)	8.74 (222.0)	7.48 (190.0)	8.35 (212.1)
F12-250	15.55 (395.0)	.31 (7.9)	3.23 (82.0)	2.63 (66.8)	4.65 (118.1)	7.76 (197.1)	9.13 (231.9)	7.87 (199.9)	7.87 (199.9)



Piston Pumps

F12 Model Ordering Code

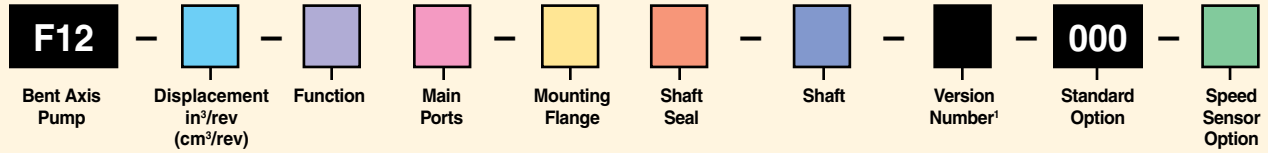

Code	Displacement in³/rev (cm³/rev)
30	1.83 in³/rev (30.0 cc/r)
40	2.44 in³/rev (40.0 cc/r)
60	3.65 in³/rev (59.8 cc/r)
80	4.91 in³/rev (80.4 cc/r)
90	5.68 in³/rev (93.0 cc/r)
110	6.72 in³/rev (110.1 cc/r)
125	7.63 in³/rev (125.0 cc/r)
150	9.15 in³/rev (150.0 cc/r)
250	14.77 in³/rev (242.0 cc/r)

Code	Function
R	Pump, CW Rotation
L	Pump, CCW Rotation

Code	Main Ports	30	40	60	80	90	110	125	150	250
S	SAE Flange	x	x	x	x	x	x	x	—	—
U	SAE, UN Threads	x	x	x	x	x	x	x	—	—
F	SAE 6000 PSI Flange	—	—	—	—	—	—	—	x	x

Code	Mounting Flange	30	40	60	80	90	110	125	150	250
S	SAE 4 bolt	x	x	x	x	x	x	x	x	x
T	SAE 2 bolt	x	x	x	—	—	x	x	—	—
X	SAE D 4 bolt	—	—	—	x	x	—	—	—	—

NOTE: ISO and cartridge mounting also available. See catalog on CD.

x: Available —: Not Available

¹Assigned by factory for special versions

²Order speed sensor kit# 3785190 separately

Code	Shaft Seal	30	40	60	80	90	110	125	150	250
N	NBR*, Low Pressure	x	x	x	x	x	x	x	x	—
V	FPM**, High Pressure, High Temperature	x	x	x	x	x	x	x	x	x

* NBR - Nitrile rubber
 ** FPM - Fluorocarbon rubber

Code	Shaft	30	40	60	80	90	110	125	150	250
S	SAE Spline (std)	x	x	x	x	x	x	x	x	x
U	SAE Spline (opt.)	—	—	—	x	x	—	—	—	—
T	SAE Key (std)	x	x	x	x	x	x	x	x	—
K	Metric Key	—	—	—	—	—	—	—	x	x
F	SAE Spline	—	—	—	—	—	—	—	—	x
D	Spline, DIN 5480	—	—	—	—	—	—	—	—	x

Code	Speed Sensor Option	30	40	60	80	90	110	125	150	250
0	Standard	x	x	x	x	x	x	x	x	x
P	Prepared for Speed Sensor	x	x	x	x	x	x	x	x	x