

# Chelsea® 912 Series

Split Shaft P.T.O.



## Overview:

The 912 Split Shaft is designed specifically for the Class 7 and 8 trucks with automatic transmissions and one or no P.T.O. openings on the transmission. This is a larger version of our popular 941 Series. The 912 features three 8-Bolt openings allowing a variety of Chelsea P.T.O.s to be mounted. This unit is an excellent choice when you need to operate more than one piece of driven equipment. This unit can be lever or air shifted. It features six input output options offering 1610, 1710 or 1810 Series flanges attached to the unit or a no flange option.

- Pumper Cleaner
- Fire and Rescue
- Tire Service Vehicles

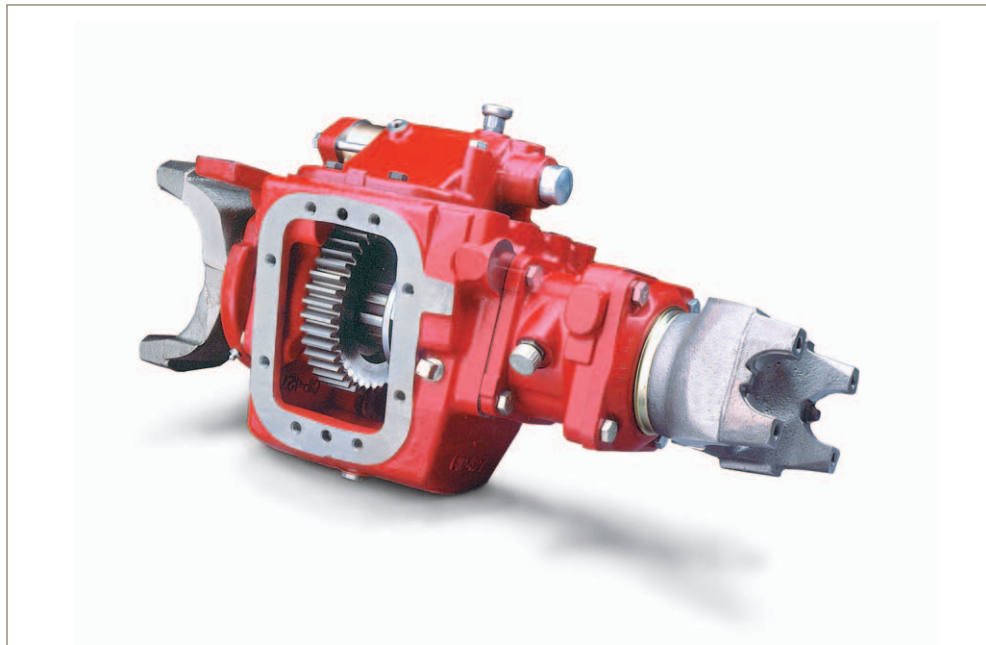

## Product Features and Benefits:

### Contact Information:

Parker Hannifin Corporation  
**Chelsea Products Division**  
8225 Hacks Cross Road  
Olive Branch, MS 38654 USA

**Phone: 1-888-PH4-TRUK**  
**(1-888-744-8785)**

**Fax: 1-662-895-1069**  
**chelseacustserv@parker.com**

[www.parker.com/chelsea](http://www.parker.com/chelsea)

- Three 8-Bolt openings that allow you to operate a variety of auxiliary equipment
- Air and Lever shift available
- Two Year Warranty
- Wide variety of 6-Bolt, 8-Bolt, Powershift, and Reversible P.T.O.s fit the 912 Series



ENGINEERING YOUR SUCCESS.

## Model Number Designator

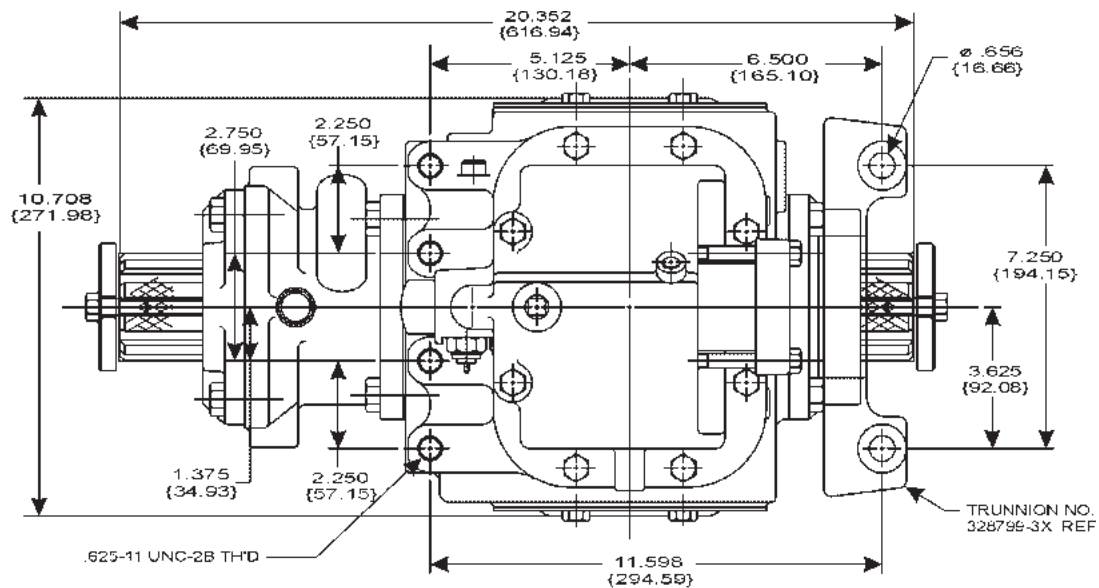
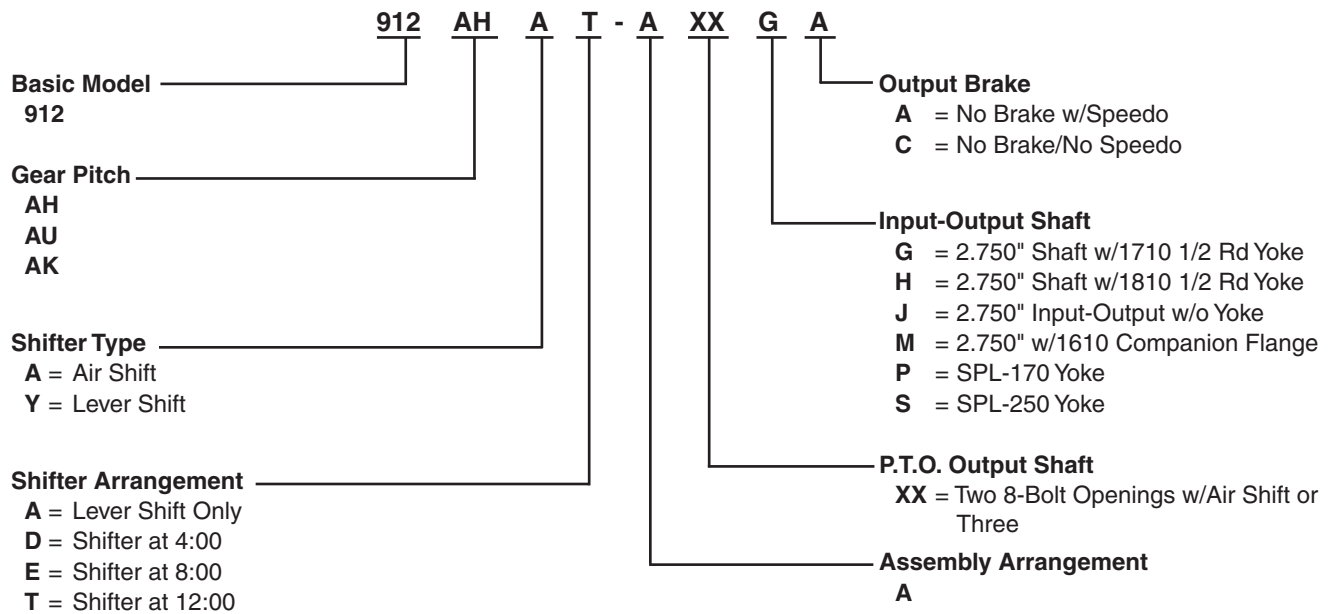

## Specifications Chart – 912 Series

	912	
Standard Output Shaft Size	— 2-3/4" 10 Spline —	
Max Thru Torque Capacity	Lbs. ft.	N.m.
w/ Diesel Engine		
Automatic Transmission	13,000	17,625
Manual Transmission	12,000	16,270
w/ Gas Engine		
Automatic Transmission	16,000	21,693
Manual Transmission	15,000	20,337
Approximate Weight:	— 130 lbs. [59 kg] —	