

Technical Information

For additional information see Technical Tips on pages BC1-BC6.

Dimensions

Millimeters (Inches)

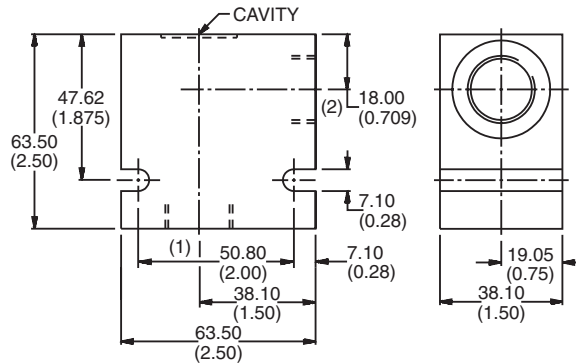
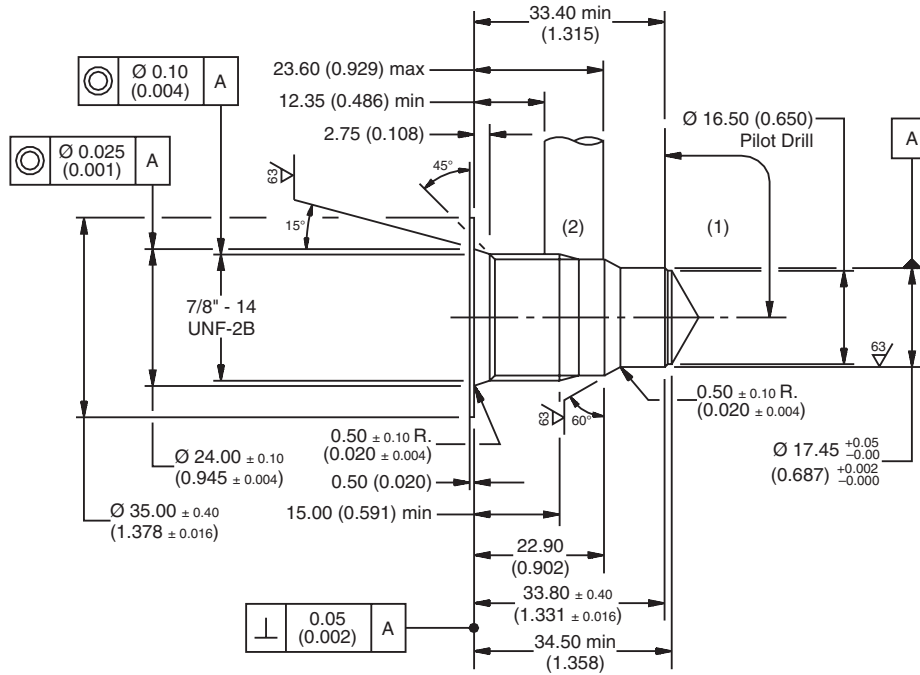

Ordering Information

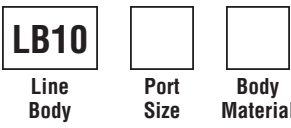

Code	Port Size
543	1/2 SAE
545	1/2 BSP

Code	Body Material
A	Aluminum
S	Steel

Cavity Tooling For 2R	
Pilot Drill	Ø
Step Drill	
Reamer (Alum)	
Reamer (Steel)	
Counterbore	
Tap	

- CV Check Valves
- SH Shuttle Valves
- LM Load/Motor Controls
- FC Flow Controls
- PC Pressure Controls
- LE Logic Elements
- DC Directional Controls
- MV Manual Valves
- SV Solenoid Valves
- PV Proportional Valves
- CE Coils & Electronics
- BC Bodies & Cavities
- TD Technical Data