

Parts List			
ITEM	QTY	PART NUMBER	DESCRIPTION
1	1	57XL-40	40 Micron FILL w/30 Mesh Stainless Strainer
2	1	APP0750-M	3/4" NPT MAG PLUG
3	1	APP1250	1 1/4" NPT SQUARE SOCKET PLUG
4	1	APP2000	2" NPT SQUARE SOCKET PLUG
5	1	N_A3250BE	NAM WELDMENT ~77 1/2 lbs
6	1	T-LLG-5	SIGHT/TEMP. GAUGE, 5"

NOTES:
 -POWDER COAT BLACK
 -APPLY RUST INHIBITOR INSIDE
 -PLUG ALL PORTS FOR SHIPMENT

WT.: ~78.88 lbs

AMERICAN MOBILE POWER PH: (800) 634-8265 FAX: (765) 948-3403	DRAWING BY: BPKNIGHT	DESIGN FOR: AMP	FILE NAME: A3250BE	
	COMPLETED: 6/18/2013		SHEET: 1 of 9	SHEET SIZE: B

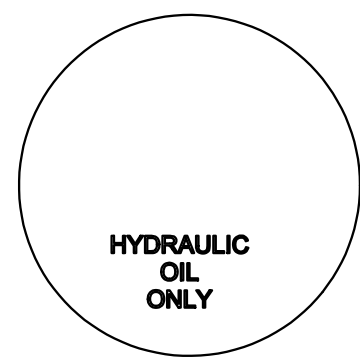
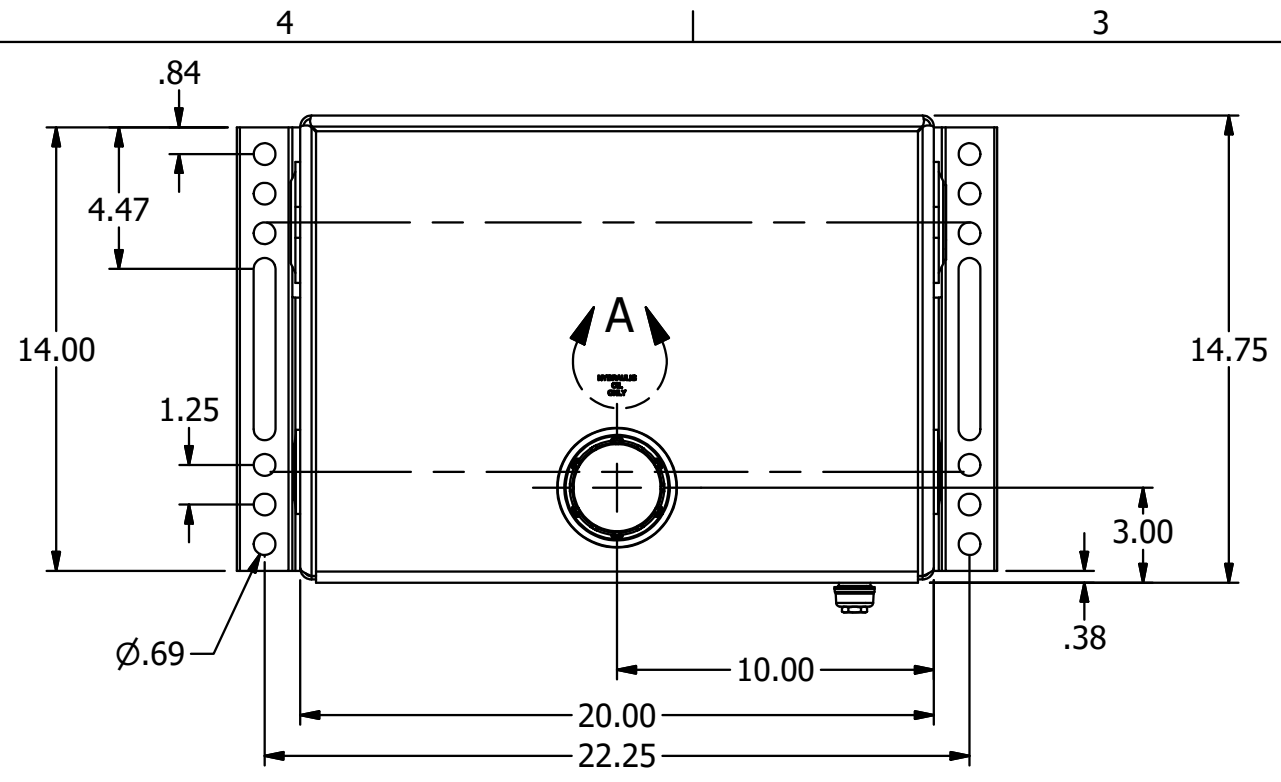

DETAIL A
SCALE .6

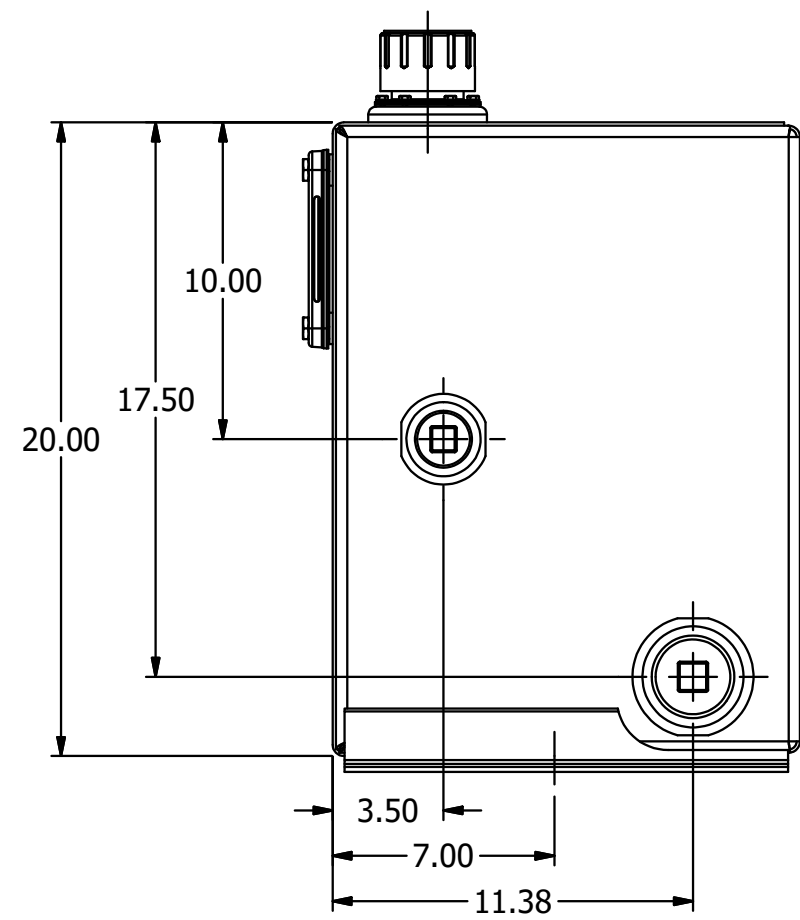
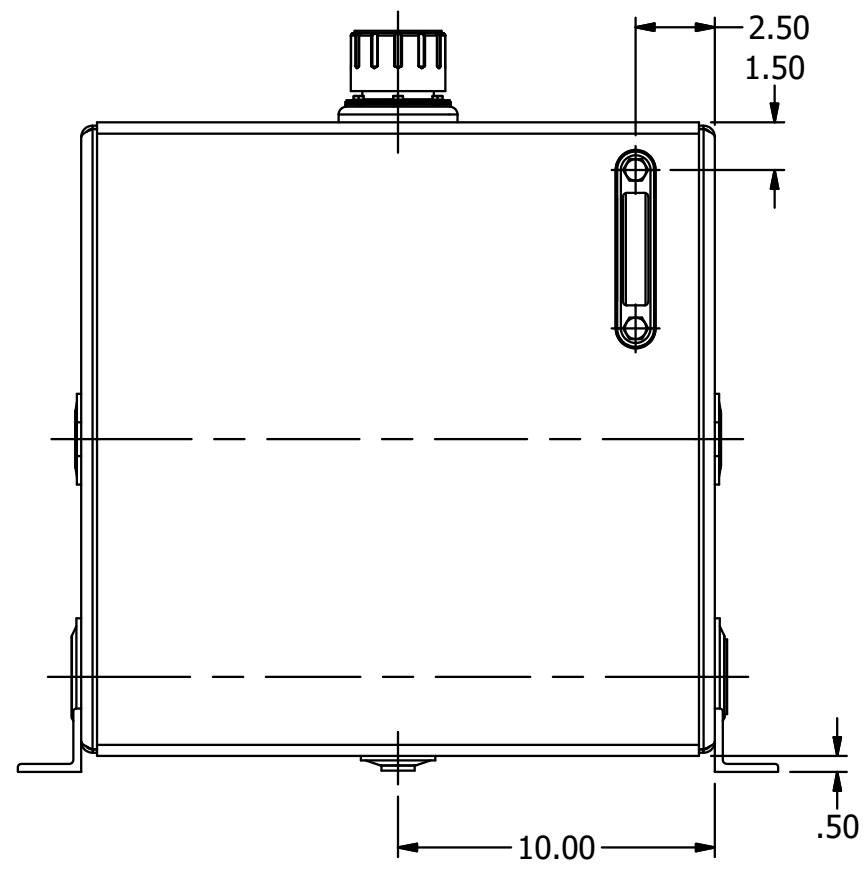
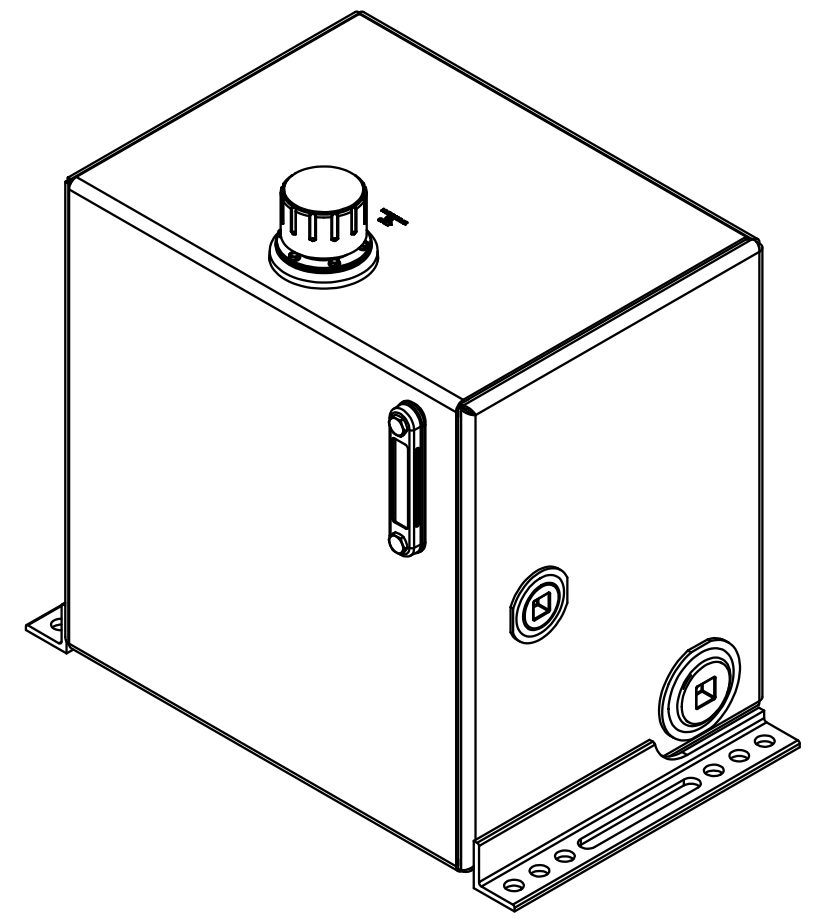

AMERICAN MOBILE POWER <small>PH: (800) 634-8265 FAX: (765) 948-3403</small>	DRAWING BY: BPKNIGHT	DESIGN FOR: AMP	FILE NAME: A3250BE	
	COMPLETED: 6/18/2013		SHEET: 2 of 9	SHEET SIZE: B

4

3

2

1

Parts List

ITEM	QTY	PART NUMBER	DESCRIPTION	Fab Qty
1	2	0500-13-FWN	1/2"-13 UNC WELD NUT	
2	1	A3250BF	12 GA HRPO BAFFLE	
3	1	A3250BS	12 GA HRPO SIDE-BACK-SIDE	
4	1	A3250FS	12 GA HRPO TOP-FRONT-BOTTOM	
5	1	A3400BEAL	2 X 2 X 1/4" MFG ANGLE	
6	1	A3400BEAR	2 X 2 X 1/4" MFG ANGLE ALT.	
7	1	AFS-301	13 GA HRPO Fill Ass'y Weld Flange	
8	1	SWF0750	3/4" NPTF STEEL WELD FLANGE	
9	2	SWF1250	1 1/4" NPSC STEEL WELD FLANGE	
10	2	SWF2000	2" NPSC STEEL WELD FLANGE	

B

B

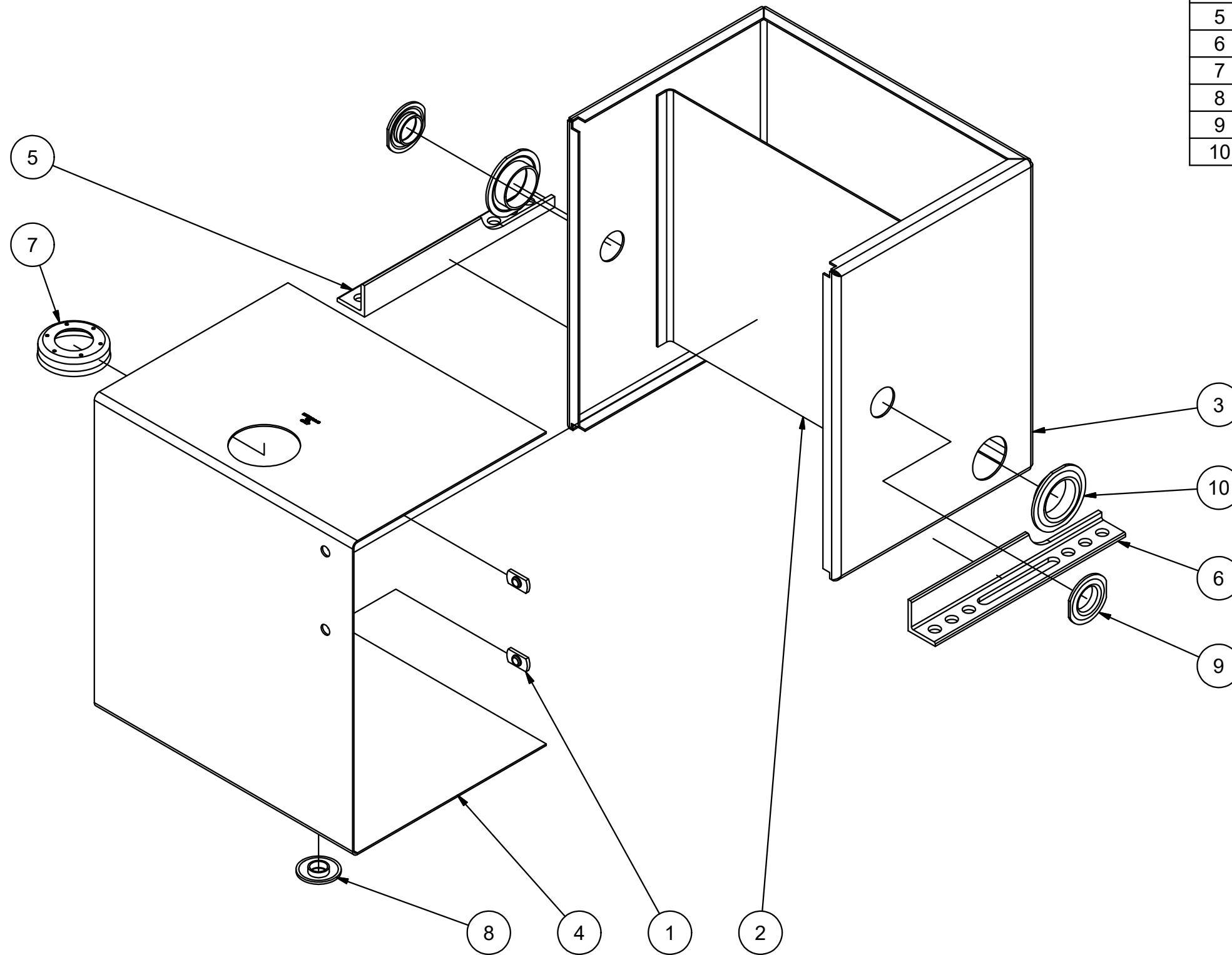

A

A

4

3

2

1

AMERICAN MOBILE POWER PH: (800) 634-8265 FAX: (765) 948-3403	DRAWING BY: BPKNIGHT	DESIGN FOR: AMP	FILE NAME: A3250BE	
	COMPLETED: 6/18/2013		SHEET: 3 of 9	SHEET SIZE: B