

American Wet Tank System

Models: AR2235, AR2250, AR2275, AR8535, AR8550 and AR8575

AR2275 and AR8575

75 Gallon Units

Requires Three Bracket Assemblies

Use Kit Number:

RMK-822-S/3 (22") or RMK-824-S/3 (24")

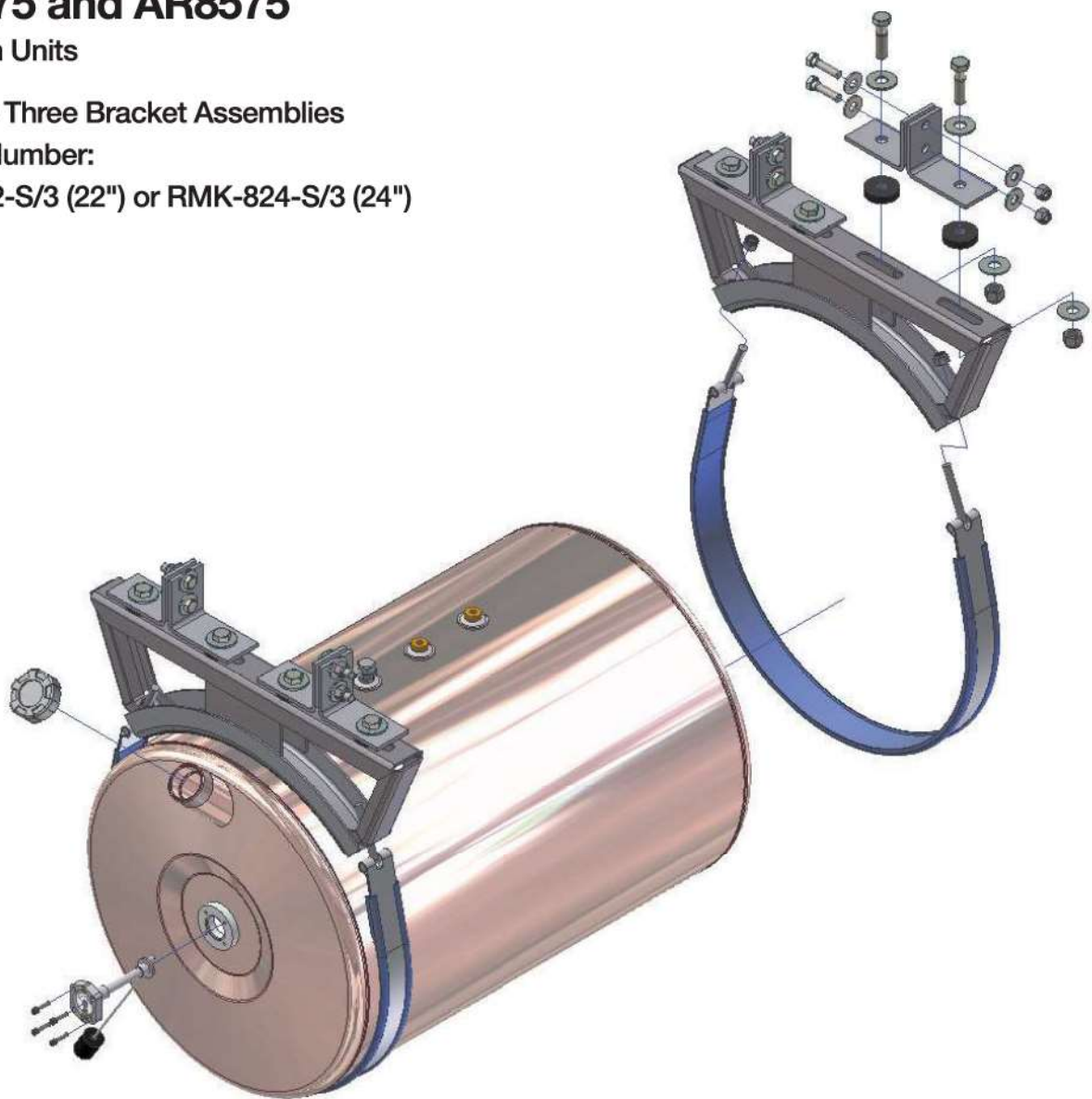

American Wet Tank System

Models: AR2235, AR2250, AR2275, AR8535, AR8550 and AR8575

Mounting Kit Contents: Part Number RMK-822-S (22") or RMK-824-S (24")

Qty Description

- 2 Heavy-duty Cradle Brackets – powder-coated, radius is rubber lined (affixed)
- 2 2" wide strap assemblies including (4) Nyloc nuts
- 2 ASK-200R Frame Mounting Kit

Pre-packaged Kit Includes:

Aluminum tank assembly (35 gallon through 75 gallon) with 2" NPT fill neck and non-vented cap; float gauge assembly (installed); three, ½" NPT top ports to accept the anti-spill vent; two, ½" x ¼" NPT pick up an return line tubes (installed); one, brass drain/check plug assembly; two, pre-punched and powder-coated, heavy-duty brackets; two, rubber-shielded stainless steel straps with Nyloc nuts; and the under body mounting hardware kit.

Instructions:

1. Position mounting angles so that the double pre-drilled holes are positioned against the frame rail and the single hole is facing down.

Note: The mounting angle should be flush with the frame rail.

2. Mark holes on frame rail and drill using a 9/16" drill bit.
3. Reposition angles and mount using supplied ½" bolt assemblies.
4. Position cradle bracket under mounting angles and attach using supplied 5/8" bolt assemblies, using the rubber space between cradle bracket and angles.
5. Place tank against brackets and firmly tighten nuts to straps (not more than 25 ft.lbs. of torque).

Note: Filter/breather cap should be periodically cleaned or replaced to prevent plugging and possible system damage.