

Effective: HY25-1670-M1/US June 2019
Supercedes: HY25-1670-M1/US April 2017



Owner's Manual Adapter Gears

626, 628, 630, 645 Series

WARNING — User Responsibility

FAILURE OR IMPROPER SELECTION OR IMPROPER USE OF THE PRODUCTS DESCRIBED HEREIN OR RELATED ITEMS CAN CAUSE DEATH, PERSONAL INJURY AND PROPERTY DAMAGE.

This document and other information from Parker-Hannifin Corporation, its subsidiaries and authorized distributors provide product or system options for further investigation by users having technical expertise.

The user, through its own analysis and testing, is solely responsible for making the final selection of the system and components and assuring that all performance, endurance, maintenance, safety and warning requirements of the application are met. The user must analyze all aspects of the application, follow applicable industry standards, and follow the information concerning the product in the current product catalog and in any other materials provided from Parker or its subsidiaries or authorized distributors.

To the extent that Parker or its subsidiaries or authorized distributors provide component or system options based upon data or specifications provided by the user, the user is responsible for determining that such data and specifications are suitable and sufficient for all applications and reasonably foreseeable uses of the components or systems.

Offer of Sale

The items described in this document are hereby offered for sale by Parker Hannifin Corporation, its subsidiaries or its authorized distributors. This offer and its acceptance are governed by the provisions stated in the Offer of Sale.



WARNING: This product can expose you to chemicals including Lead and Lead Compounds, and Di(2-ethylhexyl) phthalate (DEHP) which are known to the State of California to cause cancer and birth defects or other reproductive harm. For more information go to www.P65Warnings.ca.gov

Patent Information

The Chelsea® Power Take-Off or its components shipped with this owner's manual may be manufactured under one or more of the following U.S. patents:

7,159,701 7,007,565 6,962,093 1,326,036 60,321,840.7 9494227 B2

Other patents pending.

© Copyright 2019, Parker Hannifin Corporation, All Rights Reserved

General Information

Foreword 1

Safety Information 1-5

Installation Instructions

Mounting the Adapter Gear Assembly 6-9

Checking Backlash 10

PTO Maintenance 11

Offer of Sale 15-16

Foreword

Since our major objective is to show you how to get additional and more profitable miles from truck, tractor and trailer components, we want to provide you with information on the installation of Chelsea Power Take-Offs.

We all realize that an inadequate transmission will overwork any Power Take-Off in a very short period of time. In addition, a mismatched transmission/PTO combination can result in unsatisfactory performance of the equipment right from the start.

Before you order new trucks, be sure you're getting the right transmission/PTO combination. It is of vital importance for efficient performance to have adequate power. To help you select the proper type, size and design of PTO it is advisable to discuss your specific requirements with Chelsea PTO specialists. They know the products and have easy access to manufacturers of equipment, transmissions and Power Take-Offs. They can inform you about everything you need to know about power, at the right time, before you specify components.

Safety Information

These instructions are for your safety and the safety of the end user. Read them carefully until you understand them.

General Safety Information

To prevent injury to yourself and/or damage to the equipment:

- Read carefully all owner's manuals, service manuals, and/or other instructions.
- Always follow proper procedures, and use proper tools and safety equipment.
- Be sure to receive proper training.
- Never work alone while under a vehicle or while repairing or maintaining equipment.
- Always use proper components in applications for which they are approved.
- Be sure to assemble components properly.
- Never use wornout or damaged components.
- Always block any raised or moving device that may injure a person working on or under a vehicle.
- Never operate the controls of the Power Take-Off or other driven equipment from any position that could result in getting caught in the moving machinery.

Safety Information (Continued)

Proper Matching of PTO



WARNING: A Power Take-Off must be properly matched to the vehicle transmission and to the auxiliary equipment being powered. An improperly matched Power Take-Off could cause severe damage to the vehicle transmission, the auxiliary driveshaft, and/or the auxiliary equipment being powered. Damaged components or equipment could malfunction causing serious personal injury to the vehicle operator or to others nearby.

To avoid personal injury and/or equipment damage:

- Always refer to Chelsea catalogs, literature, and owner's manuals and follow Chelsea recommendations when selecting, installing, repairing, or operating a Power Take-Off.
- Never attempt to use a Power Take-Off not specifically recommended by Chelsea for the vehicle transmission.
- Always match the Power Take-Offs specified output capabilities to the requirements of the equipment to be powered.
- Never use a Power Take-Off whose range of speed could exceed the maximum safe speed of the equipment to be powered.

Cold Weather Operation of Powershift PTOs



WARNING: During extreme cold weather operation [32°F (0°C) and lower], a disengaged Powershift Power Take-Off can momentarily transmit high torque that will cause unexpected output shaft rotation. This is caused by the high viscosity of the transmission oil when it is extremely cold. As slippage occurs between the Power Take-Off clutch plates, the oil will rapidly heat up and the viscous drag will quickly decrease.

The Power Take-Off output shaft rotation could cause unexpected movement of the driven equipment resulting in serious personal injury, death, or equipment damage.

To avoid personal injury or equipment damage:

- Driven equipment must have separate controls.
- The driven equipment must be left in the disengaged position when not in operation.
- Do not operate the driven equipment until the vehicle is allowed to warm up.



This symbol warns of possible personal injury.

Safety Information (Continued)

Rotating Auxiliary Driveshafts



WARNING:



- Rotating auxiliary driveshafts are dangerous. You can snag clothes, skin, hair, hands, etc. This can cause serious injury or death. Exposed rotating driveshafts must be guarded.
- Do not go under the vehicle when the engine is running.
- Do not work on or near an exposed shaft when the engine is running.
- Shut off the engine before working on the Power Take-Off or driven equipment.
- Exposed rotating driveshafts must be guarded.

Guarding Auxiliary Driveshafts



WARNING: We strongly recommend that a Power Take-Off and a directly mounted pump be used to eliminate the auxiliary driveshaft whenever possible. If an auxiliary driveshaft is used and remains exposed after installation, it is the responsibility of the vehicle designer and PTO installer to install a guard.

Using Set Screws



WARNING: Auxiliary driveshafts may be installed with either recessed or protruding set screws. If you choose a square head set screw, you should be aware that it will protrude above the hub of the yoke and may be a point where clothes, skin, hair, hands, etc. could be snagged. A socket head set screw, which may not protrude above the hub of the yoke, does not permit the same amount of torquing as does a square head set screw. Also, a square head set screw, if used with a lock wire, will prevent loosening of the screw caused by vibration. Regardless of the choice made with respect to a set screw, an exposed rotating auxiliary driveshaft must be guarded.

IMPORTANT: Safety Information and Owner's Manual



This symbol warns of possible personal injury.

Safety Information (Continued)

Chelsea Power Take-Offs are packaged with safety information decals, instructions, and an owner's manual. These items are located in the envelope with the PTO mounting gaskets. Also, safety information and installation instructions are packaged with some individual parts and kits, such as adapter gear assemblies. **Be sure to read the owner's manual before installing or operating the PTO.** Always install the safety information decals according to the instructions provided. Place the owner's manual in the vehicle glove compartment.



WARNING: Operating the PTO with the Vehicle in Motion

Some Power Take-Offs may be operated when the vehicle is in motion. To do so, the PTO must have been properly selected to operate at highway speeds and correctly matched to the vehicle transmission and the requirements of the driven equipment. If in doubt about the PTO specifications and capabilities, avoid operating the PTO when the vehicle is in motion. Improper application and/or operation can cause serious personal injury or premature failure of the vehicle, the driven equipment, and/or the PTO. Always remember to disengage the PTO when the driven equipment is not in operation.

 **This symbol warns of possible personal injury.**

Safety Information (Continued)

Chelsea PTO Safety Label Instructions

1. The two black and orange on white 5" x 7" pressure sensitive vinyl labels, part number 379274, must be placed on the vehicle frame rails (one (1) on each side), in a position that would be HIGHLY visible to anyone that would go under the truck near the PTO rotating shaft. If the vehicle is to be painted after these labels are installed, cover them with two-(2) blank masking covers. Remove the masking covers after painting.
2. Place the one (1) black and orange on white 3.5" x 5" pressure sensitive vinyl label, part number 379275, on the visor nearest the operator of the vehicle, this must be placed near the PTO visor label.
3. Place the one (1) red and white with black lettering 3.5" x 7" sensitive vinyl label, part number 379915, on the opposite side of the visor from the above label part number 379275.
4. Place the one (1) white and black heavy duty card, part number 379276, in the vehicle glove box in a position highly visible to the operator. For example, try to place this card on top of whatever may be in the glove box.

If you require additional labels, please order part number 328946X at no charge from your local Chelsea Warehouse or send request direct to:

Parker Hannifin Corporation
Chelsea Products Division
 8225 Hacks Cross Road
 Olive Branch, MS 38654
 Customer Service: (662) 895-1011

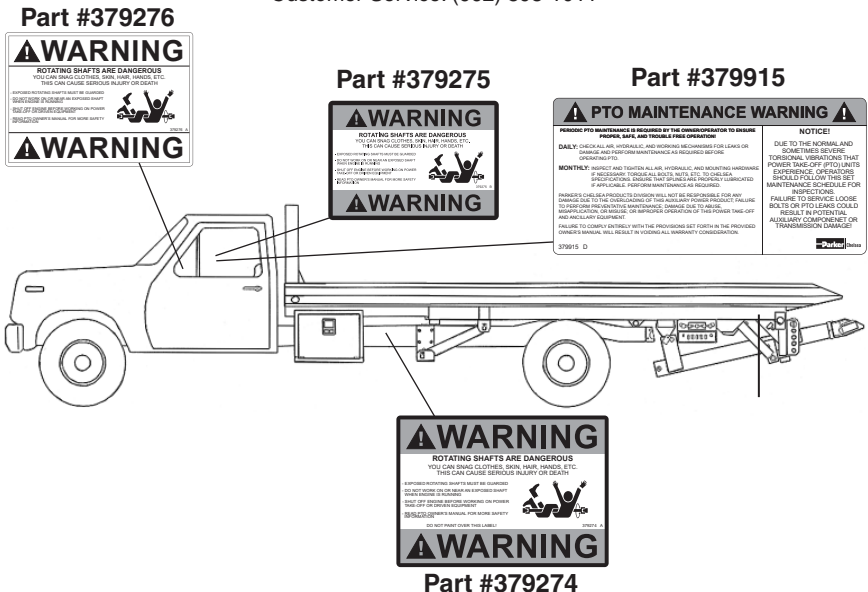

Mounting the Adapter Gear Assembly

Because it is impossible to reach the PTO driver gear in the transmission, some PTO applications require adapter assemblies.

A geared adapter assembly changes the rotation of the PTO, which may be necessary for driving pumps or other accessory equipment. Using an adapter can some times compensate for obstructions, such as a bulge in the transmission, exhausts pipes, or motor mounts.

1. Drain the oil from the transmission and remove the PTO aperture cover plate (**Fig. 1**).

CAUTION: The exhaust pipes and the oil are hot so avoid contact with them.

2. Discard the cover plate and cover plate gasket, and then clean the aperture pad using a putty knife or wire brush (**Fig. 2**).

NOTE: Stuff a rag in the aperture opening to prevent dirt from entering the transmission while you are cleaning it.

3. Install the proper studs (furnished with the PTO) in the PTO aperture pad using a stud driver. Studs may have either interference fit threads (plain) or pre-applied locking/sealing compound (**Fig. 3**).

General Rule:

A Chelsea .010" (.25 mm) gasket will change backlash approximately .006" (.15 mm), and a .020" (.50 mm) gasket changes backlash approximately .012" (.30 mm).



Typical Adapter Assembly Configurations



Fig. 1

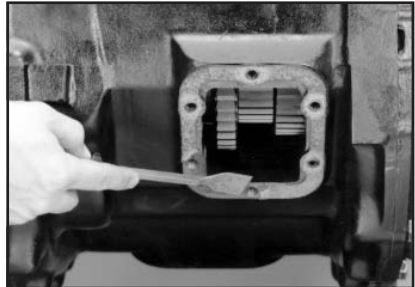

Fig. 2



Fig. 3

Mounting the Adapter Gear Assembly (Continued)

4. Install the six or eight studs until the shoulder of the stud is flush with the transmission mounting surface (Fig. 4).

CAUTION: Over tightening of studs or running the shoulder past the transmission mounting surface may damage the stud and/or transmission threads.

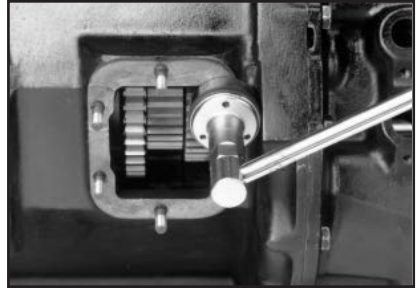

Fig. 4

5. Mount the adapter to the transmission with the gaskets provided. Then check and set backlash between the adapter and the transmission (Fig. 5).

NOTE: See [page 10](#) for checking proper backlash.

NOTE: If installing a 630-02 adapter for the Eaton I-Brake, install adapter with the gasket provided (part #35-P-96) with 630-02. There is no need to set backlash when using this gasket. Torque flange nuts at this time (See [page 9](#) Item 11 for proper torque specs.) After mounting adapter refer to installation instructions (379985) for proper I-Brake installation.



Fig. 5

6. Remove the adapter, gaskets, and filler block, if required, from the transmission. Keep the gaskets and filler block as a package (Fig. 6).



Fig. 6

7. Bench mount the adapter to the PTO. Install the appropriate length studs in the adapter body (Fig. 7).



Fig. 7

Mounting the Adapter Gear Assembly (Continued)

8. Set the proper backlash between the adapter and PTO. After backlash is set remove PTO from adapter and set aside PTO and gaskets. See [page 10](#) for setting proper backlash (**Fig. 8**).

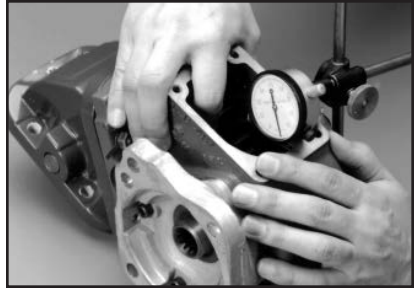

Fig. 8

9. Secure Adapter to the transmission. Use Self Locking nuts provided with Adapter (**Fig. 9**). Torque all flange nuts to their proper specifications.

NOTE: Self Locking nuts do not require lock washers.

NOTE: See torque specs in step 10.

10. Fasten the PTO to the Adapter. Torque the self locking nuts to their proper specifications.

- 379744 - 3/8" for 6-Bolt applications
35-40 lbs-ft (4.83-5.52 kg.m.)
- 379745 - 7/16-20 for 8-Bolt applications 55-60 lbs-ft (7.59-8.28 kg.m.) Torque cap screws to their proper specifications.
- 6-Bolt to 30-35 lbs-ft (4.14-4.84 kg.m.)
- 8-Bolt to 45-50 lbs-ft (6.22-6.91 kg.m.) (**Fig 10**)

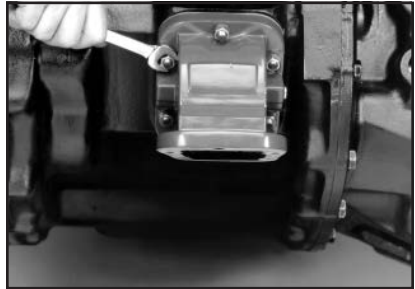

Fig. 9

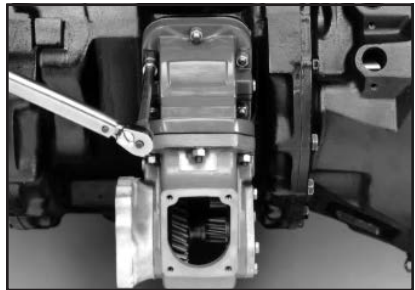

Fig.10

NOTE: If installing the Eaton Inertia Brake, refer to installation instructions (379985).

Mounting the Adapter Gear Assembly (Continued)

11. Run the PTO momentarily to check for noise.

CAUTION: The transmission and PTO have no lubrication at this time so running time should be as short as possible.

NOTE: If the PTO whines, it may be mounted too tight - too little backlash. This is an indication that gaskets should be added.

If the PTO clatters, it may be mounted too loose - too much backlash. This is an indication that gaskets should be removed.

12. Refill the transmission to its appropriate fill level. Normally, the addition of a six bolt PTO will require an additional quart of oil.

Checking Backlash

To check for proper backlash on PTOs with shift cover.

1. Remove the PTO shift housing and/or inspection plate.
2. Mount the dial indicator so that it registers movement of the input gear (driven gear) of the PTO (**Fig. 10**).

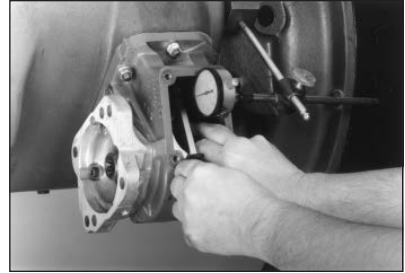

Fig. 10

NOTE: See Figure 11 for proper location of dial indicator contact point. (Two common type dial indicators shown).

3. Hold the PTO driver gear in transmission with a screwdriver or bar and rock the PTO input gear (driven gear) back and forth with your hand. Note the total movement on the dial indicator.

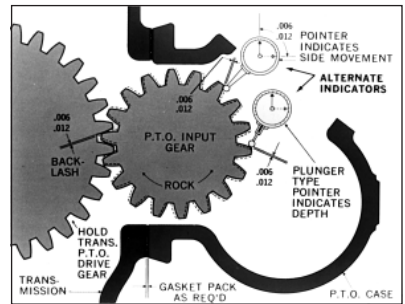

Fig. 11

4. Establish backlash at .006"-.012" [.15mm - .30mm] by adding or subtracting gaskets.

General rule: A Chelsea .010" gasket will change backlash approx. .006". A .020" gasket changes backlash approx. .012".

5. Replace the shift housing and/or inspection plate and retorque (4) four capscrews to 16 - 20 lbs-ft (2.21 - 2.76 kg meters).

Due to the normal and sometime severe torsional vibrations that Power Take-Off units experience, operators should follow a set maintenance schedule for inspections. Failure to service loose bolts or Power Take-Off leaks could result in potential auxiliary Power Take-Off or transmission damage.

Periodic PTO MAINTENANCE is required by the owner/operator to ensure proper, safe and trouble free operation.

Daily: Check all air, hydraulic and working mechanisms before operating PTO Perform maintenance as required.

Monthly: Inspect for possible leaks and tighten all air, hydraulic and mounting hardware, if necessary. Torque all bolts, nuts, etc. to Chelsea specifications. Ensure that splines are properly lubricated, if applicable. Perform maintenance as required.

With regards to the direct mounted pump splines, the PTO requires the application of a specially formulated anti-fretting, high pressure, high temperature grease. The addition of the grease has been proven to reduce the effects of the torsional vibrations, which result in fretting corrosion on the PTO internal splines as well as the pump external splines. Fretting corrosion appears as a "rusting and wearing" of the pump shaft splines. Severe duty applications, which require long PTO running times and high torque may require more frequent regreasing. Applications such as Utility Trucks that run continuously and are lightly loaded also require frequent regreasing due to the sheer hours of running time. It is important to note that service intervals will vary for each and every application and is the responsibility of the end user of the product. Chelsea also recommends that you consult your pump owners manuals and technical services for their maintenance guidelines. Fretting corrosion is caused by many factors and without proper maintenance; the anti-fretting grease can only reduce its effects on components.

Chelsea offers the grease to our customers in two packages. The first is a 5/8 fluid ounce tube (379688), which is included with every applicable PTO, and the second is a 14-ounce grease cartridge (379831).

Chelsea also offers greaseable shafts for most output designators.

Warranty: Failure to comply entirely with the provisions set forth in the appropriate Owner's Manual will result in voiding of ALL Warranty consideration.

Offer of Sale

The items described in this document and other documents and descriptions provided by Parker Hannifin Corporation, its subsidiaries and its authorized distributors ("Seller") are hereby offered for sale at prices to be established by Seller. This offer and its acceptance by any customer ("Buyer") shall be governed by all of the following Terms and Conditions. Buyer's order for any item described in its document, when communicated to Seller verbally, or in writing, shall constitute acceptance of this offer. All goods, services or work described will be referred to as "Products".

1. Terms and Conditions. Seller's willingness to offer Products, or accept an order for Products, to or from Buyer is subject to these Terms and Conditions or any newer version of the terms and conditions found on-line at www.parker.com/saleterms/. Seller objects to any contrary or additional terms or conditions of Buyer's order or any other document issued by Buyer.

2. Price Adjustments; Payments. Prices stated on Seller's quote or other documentation offered by Seller are valid for 30 days, and do not include any sales, use, or other taxes unless specifically stated. Unless otherwise specified by Seller, all prices are F.C.A. Seller's facility (INCOTERMS 2010). Payment is subject to credit approval and is due 30 days from the date of invoice or such other term as required by Seller's Credit Department, after which Buyer shall pay interest on any unpaid invoices at the rate of 1.5% per month or the maximum allowable rate under applicable law.

3. Delivery Dates; Title and Risk; Shipment. All delivery dates are approximate and Seller shall not be responsible for any damages resulting from any delay. Regardless of the manner of shipment, title to any products and risk of loss or damage shall pass to Buyer upon placement of the products with the shipment carrier at Seller's facility. Unless otherwise stated, Seller may exercise its judgment in choosing the carrier and means of delivery. No deferment of shipment at Buyer's request beyond the respective dates indicated will be made except on terms that will indemnify, defend and hold Seller harmless against all loss and additional expense. Buyer shall be responsible for any additional shipping charges incurred by Seller due to Buyer's acts or omissions.

4. Warranty. Seller warrants that all products sold, other than the 590 Series, conform to the applicable Parker Chelsea standard specification for the lesser period of 2 years (24 Months) from date of service or 2-1/2 years (30 Months) from date of build (as marked on the product name plate). Seller warrants that the 590 Series will conform to the applicable Seller standard specification for the lesser period of 2 years (24 Months) from date of service or 2000 hours of usage. The prices charged for Seller's products are based upon the exclusive limited warranty stated above, and upon the following disclaimer: **DISCLAIMER OF WARRANTY: THIS WARRANTY COMPRISES THE SOLE AND ENTIRE WARRANTY PERTAINING TO PRODUCTS PROVIDED HEREUNDER. SELLER DISCLAIMS ALL OTHER WARRANTIES, EXPRESS AND IMPLIED, INCLUDING DESIGN, MERCHANTABILITY AND FITNESS FOR A PARTICULAR PURPOSE.**

5. Claims; Commencement of Actions. Buyer shall promptly inspect all Products upon delivery. No claims for shortages will be allowed unless reported to the Seller within 10 days of delivery. No other claims against Seller will be allowed unless asserted in writing within 30 days after delivery. Buyer shall notify Seller of any alleged breach of warranty within 30 days after the date the defect is or should have been discovered by Buyer. Any action based upon breach of this agreement or upon any other claim arising out of this sale (other than an action by Seller for an amount due on any invoice) must be commenced within

12 months from the date of the breach without regard to the date breach is discovered.

6. LIMITATION OF LIABILITY. UPON NOTIFICATION, SELLER WILL, AT ITS OPTION, REPAIR OR REPLACE A DEFECTIVE PRODUCT, OR REFUND THE PURCHASE PRICE. IN NO EVENT SHALL SELLER BE LIABLE TO BUYER FOR ANY SPECIAL, INDIRECT, INCIDENTAL OR CONSEQUENTIAL DAMAGES ARISING OUT OF, OR AS THE RESULT OF, THE SALE, DELIVERY, NON-DELIVERY, SERVICING, USE OR LOSS OF USE OF THE PRODUCTS OR ANY PART THEREOF, OR FOR ANY CHARGES OR EXPENSES OF ANY NATURE INCURRED WITHOUT SELLER'S WRITTEN CONSENT, EVEN IF SELLER HAS BEEN NEGLIGENT, WHETHER IN CONTRACT, TORT OR OTHER LEGAL THEORY. IN NO EVENT SHALL SELLER'S LIABILITY UNDER ANY CLAIM MADE BY BUYER EXCEED THE PURCHASE PRICE OF THE PRODUCTS.

7. User Responsibility. The user, through its own analysis and testing, is solely responsible for making the final selection of the system and Product and assuring that all performance, endurance, maintenance, safety and warning requirements of the application are met. The user must analyze all aspects of the application and follow applicable industry standards and Product information. If Seller provides Product or system options, the user is responsible for determining that such data and specifications are suitable and sufficient for all applications and reasonably foreseeable uses of the Products or systems.

8. Loss to Buyer's Property. Any designs, tools, patterns, materials, drawings, confidential information or equipment furnished by Buyer or any other items which become Buyer's property, will be considered obsolete and may be destroyed by Seller after two consecutive years have elapsed without Buyer ordering the items manufactured using such property. Seller shall not be responsible for any loss or damage to such property while it is in Seller's possession or control.

9. Special Tooling. A tooling charge may be imposed for any special tooling, including without limitation, dies, fixtures, molds and patterns, acquired to manufacture Products. Such special tooling shall be and remain Seller's property notwithstanding payment of any charges by Buyer. In no event will Buyer acquire any interest in apparatus belonging to Seller which is utilized in the manufacture of the Products, even if such apparatus has been specially converted or adapted for such manufacture and notwithstanding any charges paid by Buyer. Unless otherwise agreed, Seller shall have the right to alter, discard or otherwise dispose of any special tooling or other property in its sole discretion at any time.

10. Buyer's Obligation; Rights of Seller. To secure payment of all sums due or otherwise, Seller shall retain a security interest in the goods delivered and this agreement shall be deemed a Security Agreement under the Uniform Commercial Code. Buyer authorizes Seller as its attorney to execute and file on Buyer's behalf all documents Seller deems necessary to perfect its security interest.

Offer of Sale (continued)

11. Improper use and Indemnity. Buyer shall indemnify, defend, and hold Seller harmless from any claim, liability, damages, lawsuits, and costs (including attorney fees), whether for personal injury, property damage, patent, trademark or copyright infringement or any other claim, brought by or incurred by Buyer, Buyer's employees, or any other person, arising out of: (a) improper selection, improper application or other misuse of Products purchased by Buyer from Seller; (b) any act or omission, negligent or otherwise, of Buyer; (c) Seller's use of patterns, plans, drawings, or specifications furnished by Buyer to manufacture Product; or (d) Buyer's failure to comply with these terms and conditions. Seller shall not indemnify Buyer under any circumstance except as otherwise provided.

12. Cancellations and Changes. Orders shall not be subject to cancellation or change by Buyer for any reason, except with Seller's written consent and upon terms that will indemnify, defend and hold Seller harmless against all direct, incidental and consequential loss or damage. Seller may change product features, specifications, designs and availability with notice to Buyer.

13. Limitation on Assignment. Buyer may not assign its rights or obligations under this agreement without the prior written consent of Seller.

14. Force Majeure. Seller does not assume the risk and shall not be liable for delay or failure to perform any of Seller's obligations by reason of circumstances beyond the reasonable control of Seller (hereinafter "Events of Force Majeure"). Events of Force Majeure shall include without limitation: accidents, strikes or labor disputes, acts of any government or government agency, acts of nature, delays or failures in delivery from carriers or suppliers, shortages of materials, or any other cause beyond Seller's reasonable control.

15. Waiver and Severability. Failure to enforce any provision of this agreement will not waive that provision nor will any such failure prejudice Seller's right to enforce that provision in the future. Invalidation of any provision of this agreement by legislation or other rule of law shall not invalidate any other provision herein. The remaining provisions of this agreement will remain in full force and effect.

16. Termination. Seller may terminate this agreement for any reason and at any time by giving Buyer thirty (30) days written notice of termination. Seller may immediately terminate this agreement, in writing, if Buyer: (a) commits a breach of any provision of this agreement (b) appoints a trustee, receiver or custodian for all or any part of Buyer's property (c) files a petition for relief in bankruptcy on its own behalf, or by a third party (d) makes an assignment for the benefit of creditors, or (e) dissolves or liquidates all or a majority of its assets.

17. Governing Law. This agreement and the sale and delivery of all Products hereunder shall be deemed to have taken place in and shall be governed and construed in accordance with the laws of the State of Ohio, as applicable to contracts executed and wholly performed therein and without regard to conflicts of laws principles. Buyer irrevocably agrees and consents to the exclusive jurisdiction and venue of the courts of Cuyahoga County, Ohio with respect to any dispute, controversy or claim arising out of or relating to this agreement.

18. Indemnity for Infringement of Intellectual Property Rights. Seller shall have no liability for infringement of any patents, trademarks, copyrights, trade dress, trade secrets or similar rights except as provided in this Section. Seller will defend and indemnify Buyer against allegations of infringement of U.S. patents, U.S. trademarks, copyrights, trade dress and trade secrets ("Intellectual Property Rights"). Seller will defend at its expense and will pay the cost of any settlement or damages awarded in an action brought against Buyer based on an allegation that a Product sold pursuant to this Agreement infringes the Intellectual Property Rights of a third party. Seller's obligation to defend and indemnify Buyer is contingent on Buyer notifying Seller within ten (10) days after Buyer becomes aware of such allegations of infringement, and Seller having sole control over the defense of any allegations or actions including all negotiations for settlement or compromise. If a Product is subject to a claim that it infringes the Intellectual Property Rights of a third party, Seller may, at its sole expense and option, procure for Buyer the right to continue using the Product, replace or modify the Product so as to make it noninfringing, or offer to accept return of the Product and return the purchase price less a reasonable allowance for depreciation. Notwithstanding the foregoing, Seller shall have no liability for claims of infringement based on information provided by Buyer, or directed to Products delivered hereunder for which the designs are specified in whole or part by Buyer, or infringements resulting from the modification, combination or use in a system of any Product sold hereunder. The foregoing provisions of this Section shall constitute Seller's sole and exclusive liability and Buyer's sole and exclusive remedy for infringement of Intellectual Property Rights.

19. Entire Agreement. This agreement contains the entire agreement between the Buyer and Seller and constitutes the final, complete and exclusive expression of the terms of sale. All prior or contemporaneous written or oral agreements or negotiations with respect to the subject matter are herein merged.

20. Compliance with Law, U.K. Bribery Act and U.S. Foreign Corrupt Practices Act. Buyer agrees to comply with all applicable laws and regulations, including both those of the United Kingdom and the United States of America, and of the country or countries of the Territory in which Buyer may operate, including without limitation the U. K. Bribery Act, the U.S. Foreign Corrupt Practices Act ("FCPA") and the U.S. Anti-Kickback Act (the "Anti-Kickback Act"), and agrees to indemnify and hold harmless Seller from the consequences of any violation of such provisions by Buyer, its employees or agents. Buyer acknowledges that they are familiar with the provisions of the U. K. Bribery Act, the FCPA and the Anti-Kickback Act, and certifies that Buyer will adhere to the requirements thereof. In particular, Buyer represents and agrees that Buyer shall not make any payment or give anything of value, directly or indirectly to any governmental official, any foreign political party or official thereof, any candidate for foreign political office, or any commercial entity or person, for the purpose of influencing such person to purchase products or otherwise benefit the business of Seller.

07/14



WARNING: This product can expose you to chemicals including Lead and Lead Compounds, and Di(2-ethylhexyl)phthalate (DEHP) which are known to the State of California to cause cancer and birth defects or other reproductive harm. For more information go to www.P65Warnings.ca.gov

Parker Worldwide

Europe, Middle East, Africa

AE – United Arab Emirates, Dubai

Tel: +971 4 8127100
parker.me@parker.com

AT – Austria, Wiener Neustadt

Tel: +43 (0)2622 23501-0
parker.austria@parker.com

AT – Eastern Europe, Wiener Neustadt

Tel: +43 (0)2622 23501 900
parker.easteurope@parker.com

AZ – Azerbaijan, Baku

Tel: +994 50 22 33 458
parker.azerbaijan@parker.com

BE/LU – Belgium, Nivelles

Tel: +32 (0)67 280 900
parker.belgium@parker.com

BG – Bulgaria, Sofia

Tel: +359 2 980 1344
parker.bulgaria@parker.com

BY – Belarus, Minsk

Tel: +375 17 209 9399
parker.belarus@parker.com

CH – Switzerland, Etoy

Tel: +41 (0)21 821 87 00
parker.switzerland@parker.com

CZ – Czech Republic, Klecany

Tel: +420 284 083 111
parker.czechrepublic@parker.com

DE – Germany, Kaarst

Tel: +49 (0)2131 4016 0
parker.germany@parker.com

DK – Denmark, Ballerup

Tel: +45 43 56 04 00
parker.denmark@parker.com

ES – Spain, Madrid

Tel: +34 902 330 001
parker.spain@parker.com

FI – Finland, Vantaa

Tel: +358 (0)20 753 2500
parker.finland@parker.com

FR – France, Contamine s/Arve

Tel: +33 (0)4 50 25 80 25
parker.france@parker.com

GR – Greece, Athens

Tel: +30 210 933 6450
parker.greece@parker.com

HU – Hungary, Budaoers

Tel: +36 23 885 470
parker.hungary@parker.com

IE – Ireland, Dublin

Tel: +353 (0)1 466 6370
parker.ireland@parker.com

IT – Italy, Corisico (MI)

Tel: +39 02 45 19 21
parker.italy@parker.com

KZ – Kazakhstan, Almaty

Tel: +7 7273 561 000
parker.easteurope@parker.com

NL – The Netherlands, Oldenzaal

Tel: +31 (0)541 585 000
parker.nl@parker.com

NO – Norway, Asker

Tel: +47 66 75 34 00
parker.norway@parker.com

PL – Poland, Warsaw

Tel: +48 (0)22 573 24 00
parker.poland@parker.com

PT – Portugal, Leca de Palmeira

Tel: +351 22 999 7360
parker.portugal@parker.com

RO – Romania, Bucharest

Tel: +40 21 252 1382
parker.romania@parker.com

RU – Russia, Moscow

Tel: +7 495 645-2156
parker.russia@parker.com

SE – Sweden, Spånga

Tel: +46 (0)8 59 79 50 00
parker.sweden@parker.com

SK – Slovakia, Banská Bystrica

Tel: +421 484 162 252
parker.slovakia@parker.com

SL – Slovenia, Novo Mesto

Tel: +386 7 337 6650
parker.slovenia@parker.com

TR – Turkey, Istanbul

Tel: +90 216 4997081
parker.turkey@parker.com

UA – Ukraine, Kiev

Tel: +380 44 494 2731
parker.ukraine@parker.com

UK – United Kingdom, Warwick

Tel: +44 (0)1926 317 878
parker.uk@parker.com

ZA – South Africa, Kempton Park

Tel: +27 (0)11 961 0700
parker.southafrica@parker.com

North America

CA – Canada, Milton, Ontario

Tel: +1 905 693 3000

MX – Mexico, Toluca

Tel: +52 72 2275 4200

Asia Pacific

AU – Australia, Castle Hill

Tel: +61 (0)2-9634 7777

CN – China, Shanghai

Tel: +86 21 2899 5000

HK – Hong Kong

Tel: +852 2428 8008

IN – India, Mumbai

Tel: +91 22 6513 7081-85

JP – Japan, Fujisawa

Tel: +81 (0)4 6635 3050

KR – South Korea, Seoul

Tel: +82 2 559 0400

MY – Malaysia, Shah Alam

Tel: +60 3 7849 0800

NZ – New Zealand, Mt Wellington

Tel: +64 9 574 1744

SG – Singapore

Tel: +65 6887 6300

TH – Thailand, Bangkok

Tel: +662 717 8140

TW – Taiwan, New Taipei City

Tel: +886 2 2298 8987

South America

AR – Argentina, Buenos Aires

Tel: +54 3327 44 4129

BR – Brazil, Cachoeirinha RS

Tel: +55 51 3470 9144

CL – Chile, Santiago

Tel: +56 2 623 1216

Pan Am, Miami

Tel: +1 305-470-8800

Parker Hannifin Corporation

Chelsea Products Division
8225 Hacks Cross Road
Olive Branch, Mississippi 38654 USA
www.parker.com/chelsea