

**Technical Information**

- CV** Check Valves
- SH** Shuttle Valves
- LM** Load/Motor Controls
- FC** Flow Controls
- PC** Pressure Controls
- LE** Logic Elements
- DC** Directional Controls
- MV** Manual Valves
- SV** Solenoid Valves
- PV** Proportional Valves
- CE** Coils & Electronics
- BC** Bodies & Cavities
- TD** Technical Data

**General Description**

Kick-Down, Spool Type, Pilot Operated Sequence Valve. For additional information see Technical Tips on pages PC1-PC6.

**Features**

- High flow capacity
- Integral 250 micron pilot flow filter
- Hardened working parts for maximum durability
- Adjustable and tamperproof versions available
- All external parts zinc plated

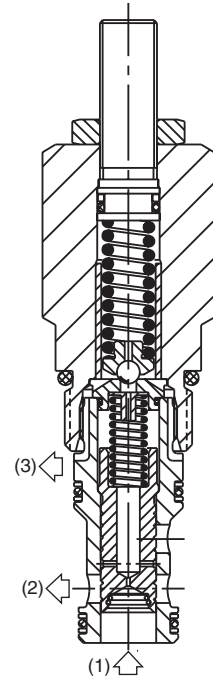
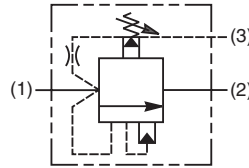
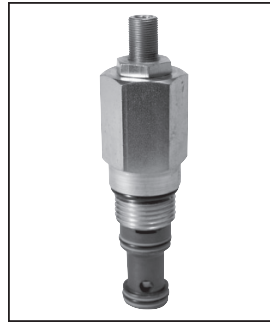

**Specifications**

<b>Rated Flow</b>	160 LPM (42 GPM)
<b>Maximum Inlet Pressure</b>	420 Bar (6000 PSI)
<b>Maximum Pressure Setting</b>	<b>H</b> - 10-210 Bar (145-3000 PSI) <b>P</b> - 10-420 Bar (145-6000 PSI)
<b>Maximum Tank Pressure</b>	420 Bar (6000 PSI)
<b>Sensitivity: Pressure/Turn</b>	<b>H</b> - 30 Bar (435 PSI) <b>P</b> - 55 Bar (800 PSI)
<b>Cartridge Material</b>	All parts steel. All operating parts hardened steel.
<b>Operating Temp. Range/Seals</b>	-40°C to +93.3°C (Nitrile) (-40°F to +200°F) -31.7°C to +121.1°C (Fluorocarbon) (-25°F to +250°F)
<b>Fluid Compatibility/Viscosity</b>	Mineral-based or synthetic with lubricating properties at viscosities of 45 to 2000 SSU (6 to 420 cSt)
<b>Filtration</b>	ISO Code 16/13, SAE Class 4 or better
<b>Approx. Weight</b>	0.27 kg (0.55 lbs.)
<b>Cavity</b>	C10-3S (See BC Section for more details)
<b>Form Tool</b>	Rougher NFT10S-3R Finisher NFT10S-3F

**Performance Curve**

(Pressure rise through cartridge only)

**Pressure Drop vs. Flow 1 to 2**

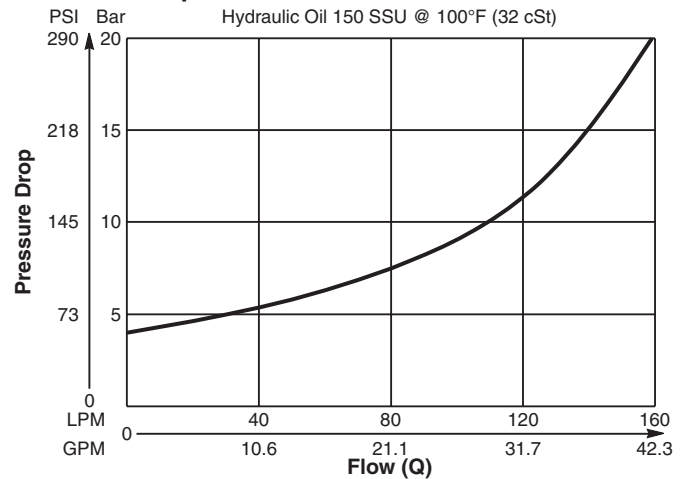

**Application Note**

Valve unloads completely when setting is reached and resets when fluid supply is removed.

**Dimensions** Millimeters (Inches)

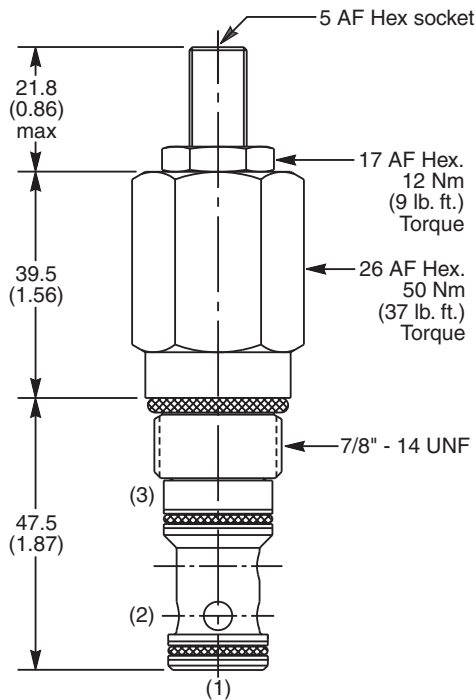

**Ordering Information**

<b>B04C3</b>	<input type="checkbox"/>	<input type="checkbox"/>	<input type="checkbox"/>	<input type="checkbox"/>	<input type="checkbox"/>
<b>10 Size Kick-Down Pilot Operated Sequence Valve</b>	<b>Pressure Adjustment Range</b>	<b>Adjustment Style</b>	<b>Optional Pressure Setting</b>	<b>Seals</b>	

Code	Pressure Adjustment Range
H	10 - 210 Bar (145 - 3000 PSI)
P	10 - 420 Bar (145 - 6000 PSI)

Optional Pressure Setting	
Specify setting if required (Bar)	
<b>B04C3H</b> Standard Setting: 100 Bar (1450 PSI)	
<b>B04C3P</b> Standard Setting: 200 Bar (2900 PSI)	

Code	Adjustment Style / Kit No.
Z	Screw Adjust (Std.)
W	Knob Adjust
T	Tamper Resistant Cap (TC1130)

Code	Seals / Kit No.
N	Nitrile, Buna-N (Std.) / (SK30504N-1)
V	Fluorocarbon / (SK30504V-1)

*Order Bodies Separately*

<b>LB10</b>	<input type="checkbox"/>	<input type="checkbox"/>
Line Body	Porting	Body Material

Code	Porting
710	5/8" SAE (main) 3/8" SAE (aux)
711	3/4" BSP (main) 1/4" BSP (aux)

Code	Body Material
A	Aluminum
S	Steel

- CV** Check Valves
- SH** Shuttle Valves
- LM** Load/Motor Controls
- FC** Flow Controls
- PC** Pressure Controls
- LE** Logic Elements
- DC** Directional Controls
- MV** Manual Valves
- SV** Solenoid Valves
- PV** Proportional Valves
- CE** Coils & Electronics
- BC** Bodies & Cavities
- TD** Technical Data