

**Technical Information**

- CV** Check Valves
- SH** Shuttle Valves
- LM** Load/Motor Controls
- FC** Flow Controls
- PC** Pressure Controls
- LE** Logic Elements
- DC** Directional Controls
- MV** Manual Valves
- SV** Solenoid Valves
- PV** Proportional Valves
- CE** Coils & Electronics
- BC** Bodies & Cavities
- TD** Technical Data

**General Description**

Pilot Operated Spool-Type Relief Valve  
For addition information see Technical Tips on pages PC1-PC6.



**Features**

- Hardened, precision ground parts for durability
- Low profile adapter for minimal space requirements
- Fully guided poppet for more consistent reseal
- Steel adapters are coated with yellow zinc dichromate for protection from salt spray
- Polyurethane "D"-Ring eliminates backup rings and prevents hydrolysis
- Internal screening protects pilot spring from debris

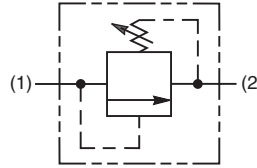
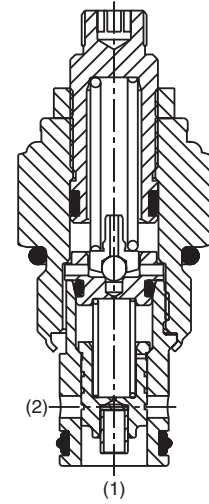

**Specifications**

<b>Rated Flow</b>	113 LPM (30 GPM)
<b>Maximum Inlet Pressure</b>	380 Bar (5500 PSI)
<b>Maximum Pressure Setting</b>	350 Bar (5000 PSI)
<b>Maximum Tank Pressure</b>	350 Bar (5000 PSI)
<b>Reseat Pressure</b>	90% of crack pressure
<b>Leakage at 150 SSU (32 cSt)</b>	5 cc per 100 PSI (6.8 Bar) setting
<b>Cartridge Material</b>	All parts steel. All operating parts hardened steel.
<b>Operating Temp. Range/Seals</b>	-45°C to +93.3°C ("D"-Ring) (-50°F to +200°F) -31.7°C to +121.1°C (Fluorocarbon) (-25°F to +250°F)
<b>Fluid Compatibility/ Viscosity</b>	Mineral-based or synthetic with lubricating properties at viscosities of 45 to 2000 SSU (6 to 420 cSt)
<b>Filtration</b>	ISO Code 16/13, SAE Class 4 or better
<b>Approx. Weight</b>	.23 kg (.50 lbs.)
<b>Cavity</b>	C10-2 (See BC Section for more details)
<b>Form Tool</b>	Rougher None Finisher NFT10-2F

**Performance Curves**

**Flow vs. Inlet Pressure**

(Pressure rise through cartridge only)

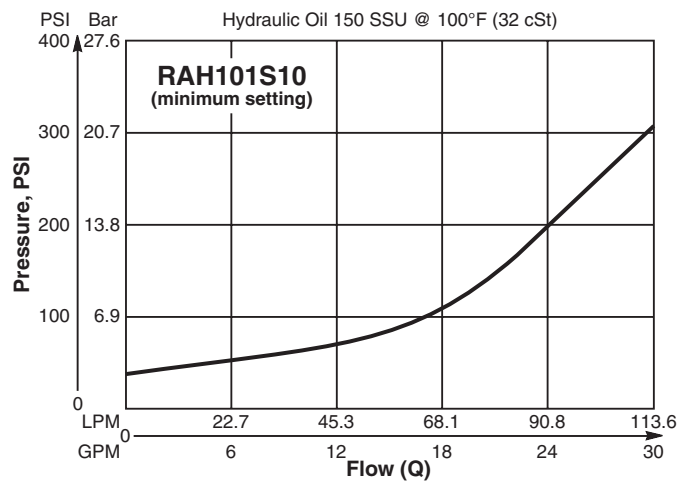
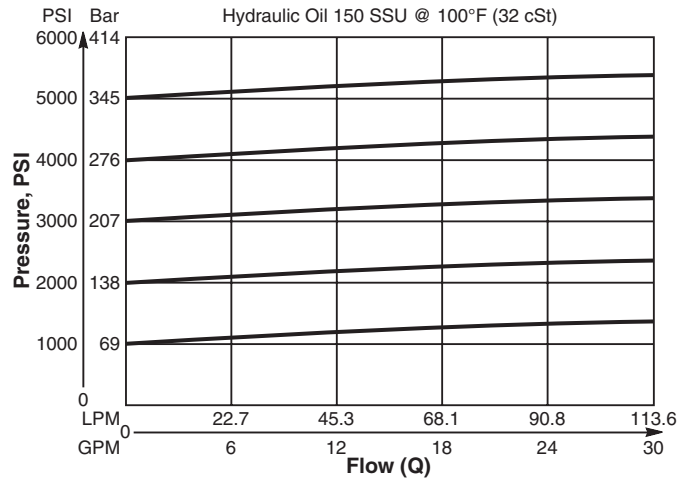

**Dimensions** Millimeters (Inches)

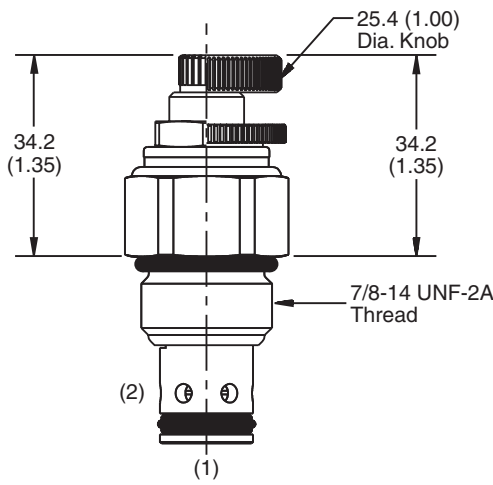

**Screw/Knob Version**

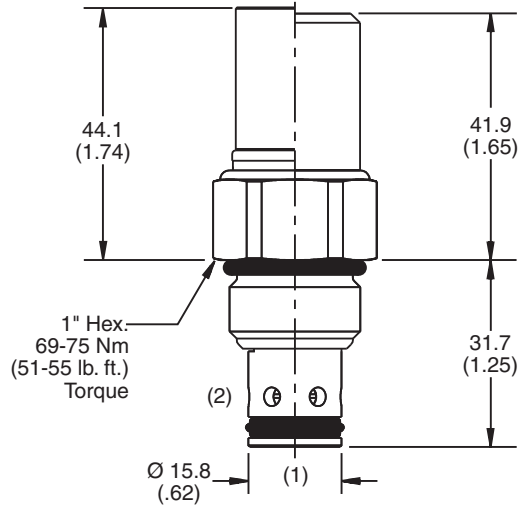

**Fixed Cap/Tamper Resistant Version**

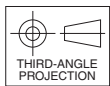

**Ordering Information**

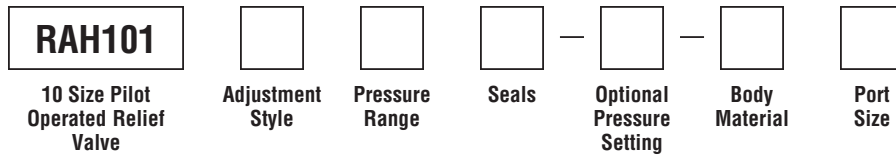

Code	Adjustment Style / Kit No.
F	Fixed style, preset at factory.
K	Knob Adjust (717784-10)
S	Screw Adjust
T	Tamper Resistant Cap (718083)

Code	Seals / Kit No.
Omit	"D"-Ring / (SK10-2)
N	Nitrile / (SK10-2N)
V	Fluorocarbon / (SK10-2V)

Code	Body Material
Omit	Steel
A	Aluminum

Code	Pressure Range
10	6.9 - 69 Bar (100 - 1000 PSI) Standard Setting: 34.5 Bar (500 PSI) @ crack pressure, approximately .95 LPM (.25 GPM)
20	6.9 - 138 Bar (100 - 2000 PSI) Standard Setting: 69 Bar (1000 PSI) @ crack pressure, approximately .95 LPM (.25 GPM)
30	13.8 - 207 Bar (200 - 3000 PSI) Standard Setting: 103.5 Bar (1500 PSI) @ crack pressure, approximately .95 LPM (.25 GPM)
50	13.8 - 345 Bar (200 - 5000 PSI) Standard Setting: 172.4 Bar (2500 PSI) @ crack pressure, approximately .95 LPM (.25 GPM)

Optional Pressure Setting
Pressure ÷ 10 i.e. 235 = 2350 PSI (Omit if standard setting is used) Setting Range: 100 to 5000 PSI All settings at crack pressure, approximately .95 LPM (.25 GPM)

Code	Port Size	Body Part No.
Omit	Cartridge Only	
4P	1/4" NPTF	(B10-2-*4P)
6P	3/8" NPTF	(B10-2-*6P)
8P	1/2" NPTF	(B10-2-*8P)
6T	SAE-6	(B10-2-*6T)
8T	SAE-8	(B10-2-*8T)
T8T	SAE-8	(B10-2-T8T)†
6B	3/8" BSPG	(B10-2-6B)†

\* Add "A" for aluminum, omit for steel.  
 † Steel body only.