

**Technical Information**

- CV** Check Valves
- SH** Shuttle Valves
- LM** Load/Motor Controls
- FC** Flow Controls
- PC** Pressure Controls
- LE** Logic Elements
- DC** Directional Controls
- MV** Manual Valves
- SV** Solenoid Valves
- PV** Proportional Valves
- CE** Coils & Electronics
- BC** Bodies & Cavities
- TD** Technical Data

**General Description**

2-Way Poppet Valves. For additional information see Technical Tips on pages SV1-SV6.

**Features**

- Low hysteresis
- Replaceable, one piece encapsulated coils with minimal amperage draw
- Various coil terminations and voltages
- Various manual override options
- All external parts zinc plated

**Specifications**

<b>Rated Flow</b>	90 LPM (24 GPM)		
<b>Maximum Inlet Pressure</b>	350 Bar (5000 PSI)		
<b>Leakage at 150 SSU (32 cSt)</b>	5 drops/min. (.33 cc/min.)		
<b>Minimum Operating Voltage</b>	85% of rated voltage at 20°C (72°F).		
<b>Response Time</b>		<b>Energized</b>	<b>De-Energized</b>
	<b>C, CR</b>	100 ms	150 ms
	<b>CH, CHR</b>	60 ms	60 ms
	<b>N, NR</b>	70 ms	150 ms
<b>Cartridge Material</b>	All parts steel. All operating parts hardened steel.		
<b>Operating Temp. Range/Seals</b>	-40°C to +93.3°C (Nitrile) (-40°F to +200°F) -31.7°C to +121.1°C (Fluorocarbon) (-25°F to +250°F)		
<b>Fluid Compatibility/ Viscosity</b>	Mineral-based or synthetic with lubricating properties at viscosities of 45 to 2000 SSU (6 to 420 cSt)		
<b>Filtration</b>	ISO Code 16/13, SAE Class 4 or better		
<b>Approx. Weight</b>	.29 kg (.65 lbs.)		
<b>Cavity</b>	C12-2 (See BC Section for more details)		
<b>Form Tool</b>	Rougher Finisher	None	NFT12-2F

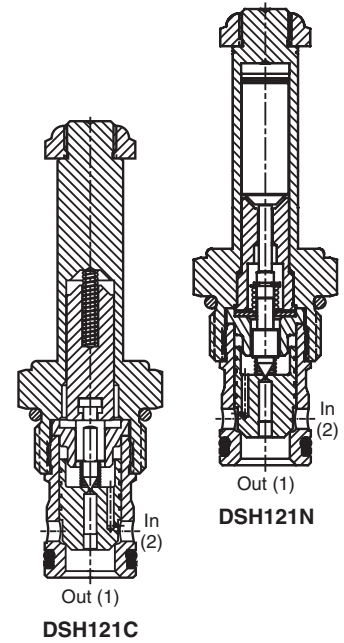
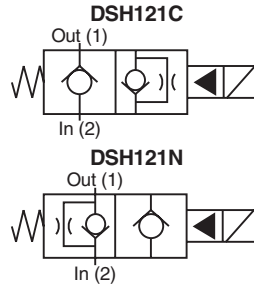

**Performance Curves**

Pressure Drop vs. Flow (Through cartridge only)

**Normally Closed**

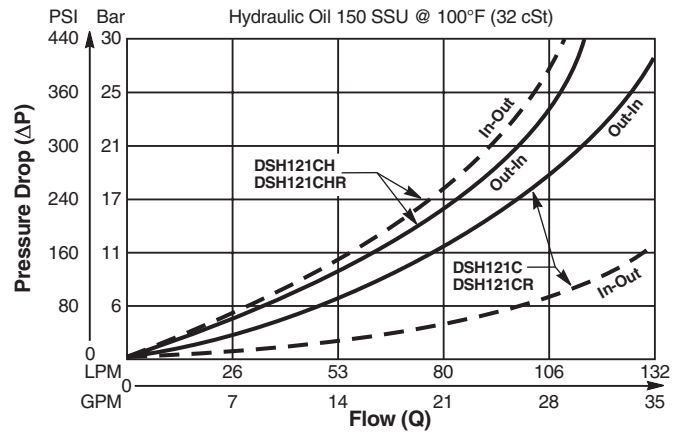

**Normally Open**

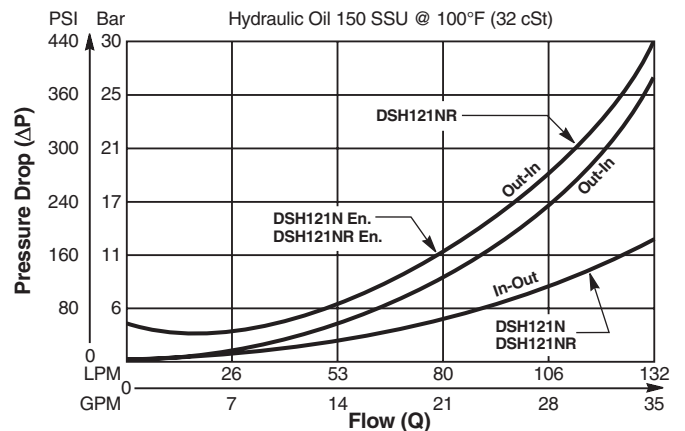

**Dimensions** Millimeters (Inches)

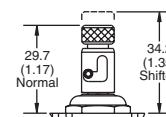
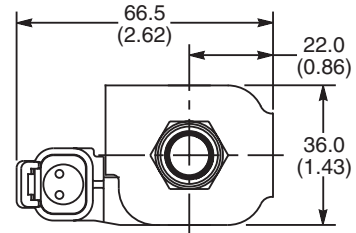
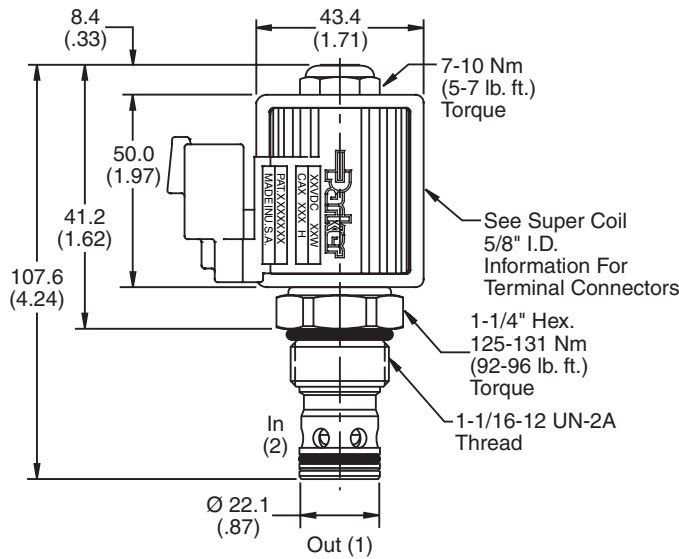

**Push and Twist M.O.**  
 (Normally Closed Valves Only)

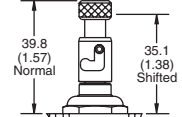

**Push and Twist M.O.**  
 (Normally Open Valves Only)

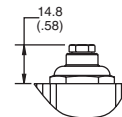

**Flush M.O.**  
 (Normally Open Valves Only)

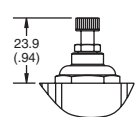

**Extended M.O.**  
 (Normally Open Valves Only)

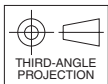

**Ordering Information**

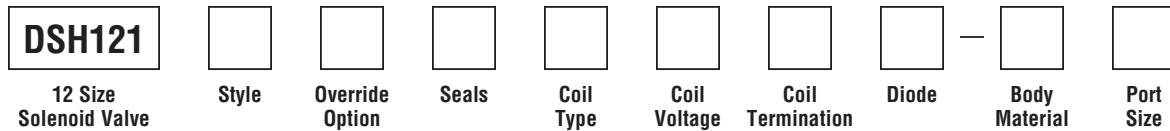

Code / Style	Diagram
<b>C</b> Normally Closed Metered reverse flow	
<b>CH</b> Normally Closed Metered reverse flow (Fast response)	
<b>CHR</b> Normally Closed Full reverse flow (Fast response)	
<b>CR</b> Normally Closed Free reverse flow	
<b>N</b> Normally Open Metered reverse flow	
<b>NR</b> Normally Open Free reverse flow	

Code	Override Options
<b>Omit</b>	None
<b>E</b>	Push Type with Extended Rod (N.O. Only)
<b>M</b>	Push Type with Flush Rod (N.O. Only)
<b>T</b>	Push & Twist (N.C. & N.O.)

Code	Seals / Kit No.
<b>Omit</b>	Nitrile / (SK12-2)
<b>V</b>	Fluorocarbon / (SK12-2V)

Code	Coil Type
<b>Omit</b>	Without Coil
<b>SP*</b>	Super Coil - 28 Watts

*\*Recommended*

Code	Coil Voltage
<b>Omit</b>	Without Coil
<b>D012</b>	12 VDC
<b>D024</b>	24 VDC
<b>A120</b>	120/110 VAC, 60/50 Hz
<b>A240</b>	240/220 VAC, 60/50 Hz

SP* Coil	Coil Termination
<b>Omit</b>	Without Coil
<b>C</b>	Conduit With Leads
<b>D</b>	DIN Plug Face
<b>A</b>	Amp Jr. Timert†
<b>S</b>	Dual Spade†
<b>L</b>	Dual Lead Wire†
<b>LS</b>	Sealed Lead Wire†
<b>H</b>	Molded Deutsch†

*\*Recommended †DC Only*

Code	Diode
<b>Omit</b>	None
<b>R</b>	Diode

Code	Body Material
<b>Omit</b>	Steel
<b>A</b>	Aluminum

Code	Port Size	Body Part No.
<b>Omit</b>		Cartridge Only
<b>12P</b>	3/4" NPTF	(B12-2-*12P)
<b>8T</b>	SAE-8	(B12-2-*8T)
<b>12T</b>	SAE-12	(B12-2-*12T)

*\* Add "A" for aluminum, omit for steel.*