

Technical Information

- CV** Check Valves
- SH** Shuttle Valves
- LM** Load/Motor Controls
- FC** Flow Controls
- PC** Pressure Controls
- LE** Logic Elements
- DC** Directional Controls
- MV** Manual Valves
- SV** Solenoid Valves
- PV** Proportional Valves
- CE** Coils & Electronics
- BC** Bodies & Cavities
- TD** Technical Data

General Description

2-Way Poppet Valves. For additional information see Technical Tips on pages SV1-SV6.



Features

- Replaceable, one piece encapsulated, coils with minimal amperage draw
- Variety of coil terminations and voltages
- Variety of manual override options available
- Fast response available, (CH and CHR) rated at 15 LPM (4.0 GPM)
- Polyurethane "D"-Ring eliminates need for backup rings
- Spherical poppet for low leakage
- Nylon inserted jam-nut provides secure holding in high vibration applications
- All external parts zinc plated

Specifications

Rated Flow (At 70 PSI ΔP)	30 LPM (8 GPM)	
Maximum Inlet Pressure	250 Bar (3600 PSI)	
Leakage at 150 SSU (32 cSt)	5 drops/min. (.33 cc/min.)	
Minimum Operating Voltage	85% of rated voltage at 20°C (72°F).	
Response Time	Energized	De-Energized
C, CR	50 ms	50 ms
CH, CHR	30 ms	50 ms
N, NR	50 ms	40 ms
Cartridge Material	All parts steel. All operating parts hardened steel.	
Operating Temp. Range/Seals	-45°C to +93.3°C ("D"-Ring) (-50°F to +200°F) -31.7°C to +121.1°C (Fluorocarbon) (-25°F to +250°F)	
Fluid Compatibility/Viscosity	Mineral-based or synthetic with lubricating properties at viscosities of 45 to 2000 SSU (6 to 420 cSt)	
Filtration	ISO Code 16/13, SAE Class 4 or better	
Approx. Weight	.11 kg (.25 lbs.)	
Cavity	C08-2 (See BC Section for more details)	
Form Tool	Rougher	None
	Finisher	NFT08-2F

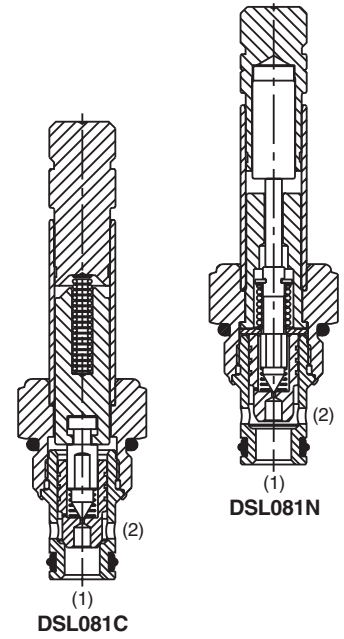
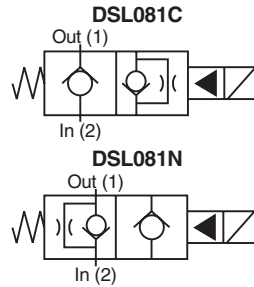

Performance Curves

Pressure Drop vs. Flow (Through cartridge only)

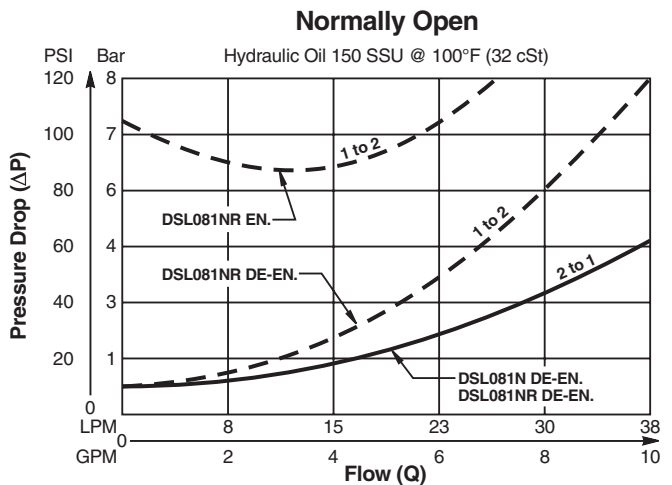
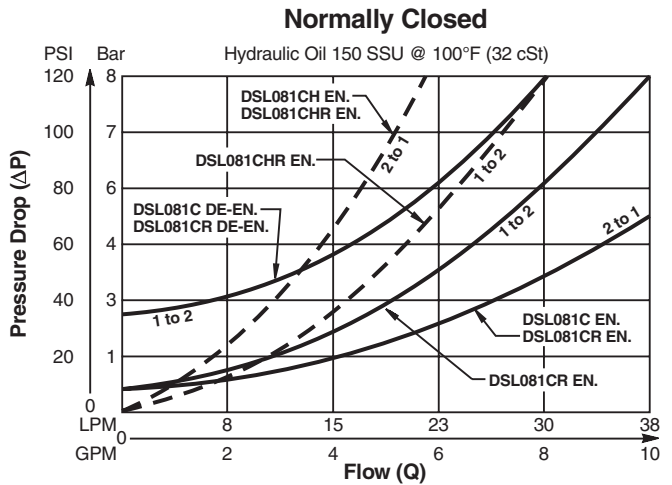

Dimensions Millimeters (Inches)

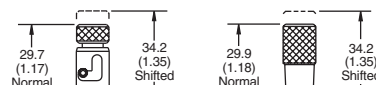
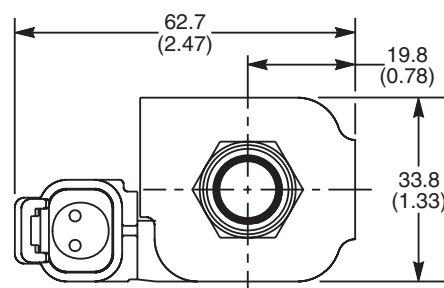
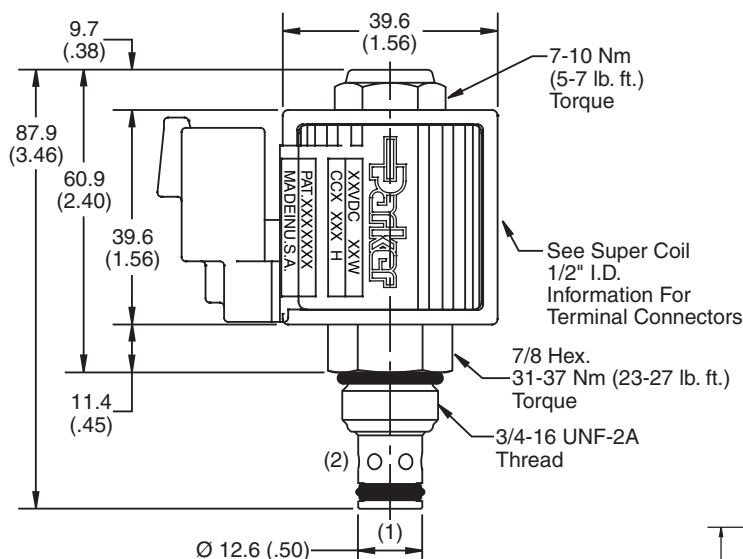

Push and Twist M.O.
 (Normally Closed Valves Only)

Pull and Release M.O.
 (Normally Closed Valves Only)

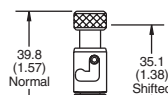

Push and Twist M.O.
 (Normally Open Valves Only)

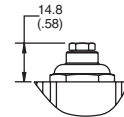

Flush M.O.
 (Normally Open Valves Only)

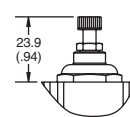

Extended M.O.
 (Normally Open Valves Only)

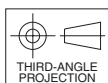

Ordering Information

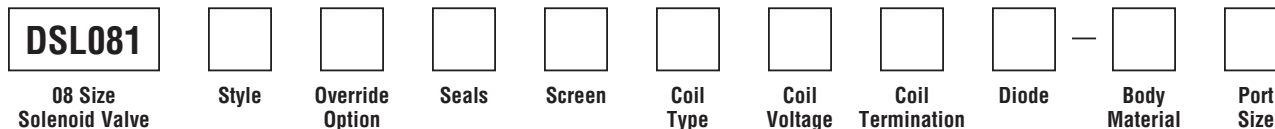

Code / Style	Symbol
C Normally Closed Metered reverse flow	
CH Normally Closed Metered reverse flow (Fast response)	
CHR Normally Closed Full reverse flow (Fast response)	
CR Normally Closed Free reverse flow	
N Normally Open Metered reverse flow	
NR Normally Open Free reverse flow	

Code	Override Options
Omit	None
E	Push Type with Extended Rod (N.O. Only)
M	Push Type with Flush Rod (N.O. Only)
P	Pull & Release (N.C. Only)
T	Push & Twist (N.C. & N.O.)

Code	Seals / Kit No.
Omit	"D"-Ring / (SK08-2)
N	Nitrile / (SK08-2N)
V	Fluorocarbon / (SK08-2V)

Code	Screen
Omit	None
S	Screen

Code	Coil Type
Omit	Without Coil
SP*	Super Coil - 19 Watts

**Recommended*

Code	Coil Voltage
Omit	Without Coil
D012	12 VDC
D024	24 VDC
A120	120/110 VAC, 60/50 Hz
A240	240/220 VAC, 60/50 Hz

SP* Coil	Coil Termination
Omit	Without Coil
C	Conduit With Leads
D	DIN Plug Face
A	Amp Jr. Timert†
S	Dual Spade†
L	Dual Lead Wire†
LS	Sealed Lead Wire†
H	Molded Deutsch†

**Recommended †DC Only*

Code	Diode
Omit	None
R	Diode

Code	Body Material
Omit	Steel
A	Aluminum

Code	Port Size	Body Part No.
Omit	Cartridge Only	
4P	1/4" NPTF	(B08-2-*4P)
6P	3/8" NPTF	(B08-2-*6P)
4T	SAE-4	(B08-2-*4T)
6T	SAE-6	(B08-2-*6T)
6B	3/8" BSPG	(B08-2-*6B)

** Add "A" for aluminum, omit for steel.*