

Technical Information

General Description

2-Way Poppet Valves. For additional information see Technical Tips on pages SV1-SV6.



Features

- Low hysteresis
- Replaceable, one piece encapsulated coils with minimal amperage draw
- Various coil terminations and voltages
- Various manual override options
- Fast response available, (CH and CHR) rated at 11 LPM (3.0 GPM)
- Polyurethane "D"-Ring
- All external parts zinc plated

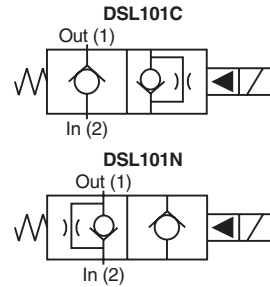
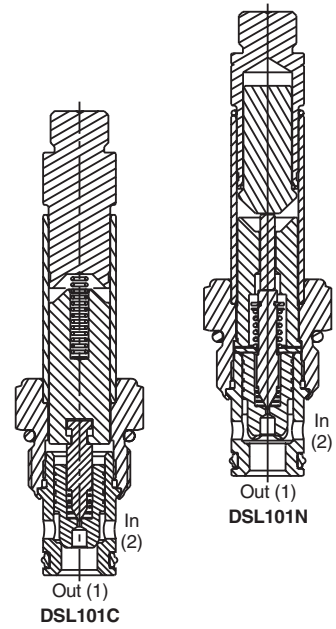

Specifications

Rated Flow (At 70 PSI ΔP)	60 LPM (15 GPM)		
Maximum Inlet Pressure	250 Bar (3600 PSI)		
Leakage at 150 SSU (32 cSt)	5 drops/min. (.33 cc/min.)		
Minimum Operating Voltage	85% of rated voltage at 20°C (72°F).		
Response Time		Energized	De-Energized
C, CR		80 ms	150 ms
CH, CHR		50 ms	50 ms
N, NR		35 ms	175 ms
Cartridge Material	All parts steel. All operating parts hardened steel.		
Operating Temp. Range/Seals	-45°C to +93.3°C ("D"-Ring) (-50°F to +200°F) -31.7°C to +121.1°C (Fluorocarbon) (-25°F to +250°F)		
Fluid Compatibility/Viscosity	Mineral-based or synthetic with lubricating properties at viscosities of 45 to 2000 SSU (6 to 420 cSt)		
Filtration	ISO Code 16/13, SAE Class 4 or better		
Approx. Weight	.20 kg (0.41 lbs.)		
Cavity	C10-2 (See BC Section for more details)		
Form Tool	Rougher Finisher	None	NFT10-2F

Performance Curves

Pressure Drop vs. Flow (Through cartridge only)

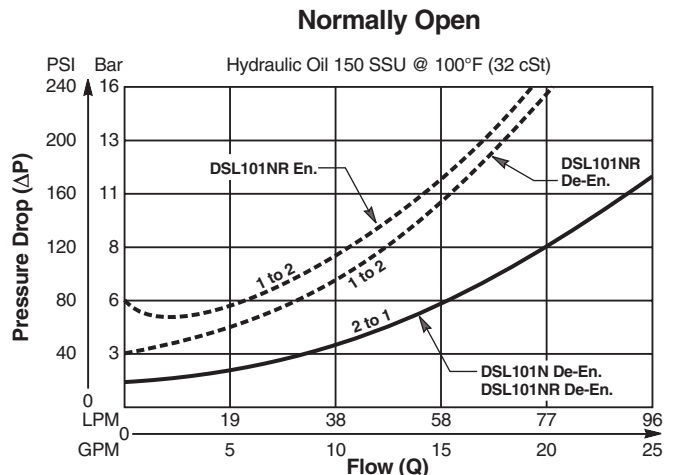
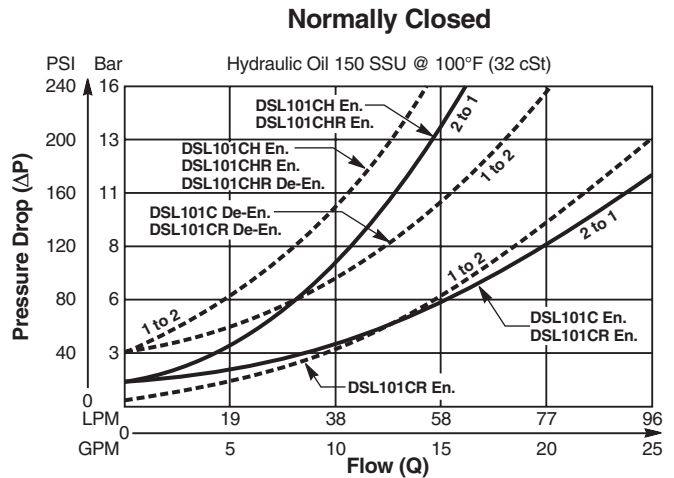

- CV** Check Valves
- SH** Shuttle Valves
- LM** Load/Motor Controls
- FC** Flow Controls
- PC** Pressure Controls
- LE** Logic Elements
- DC** Directional Controls
- MV** Manual Valves
- SV** Solenoid Valves
- PV** Proportional Valves
- CE** Coils & Electronics
- BC** Bodies & Cavities
- TD** Technical Data

Dimensions Millimeters (Inches)

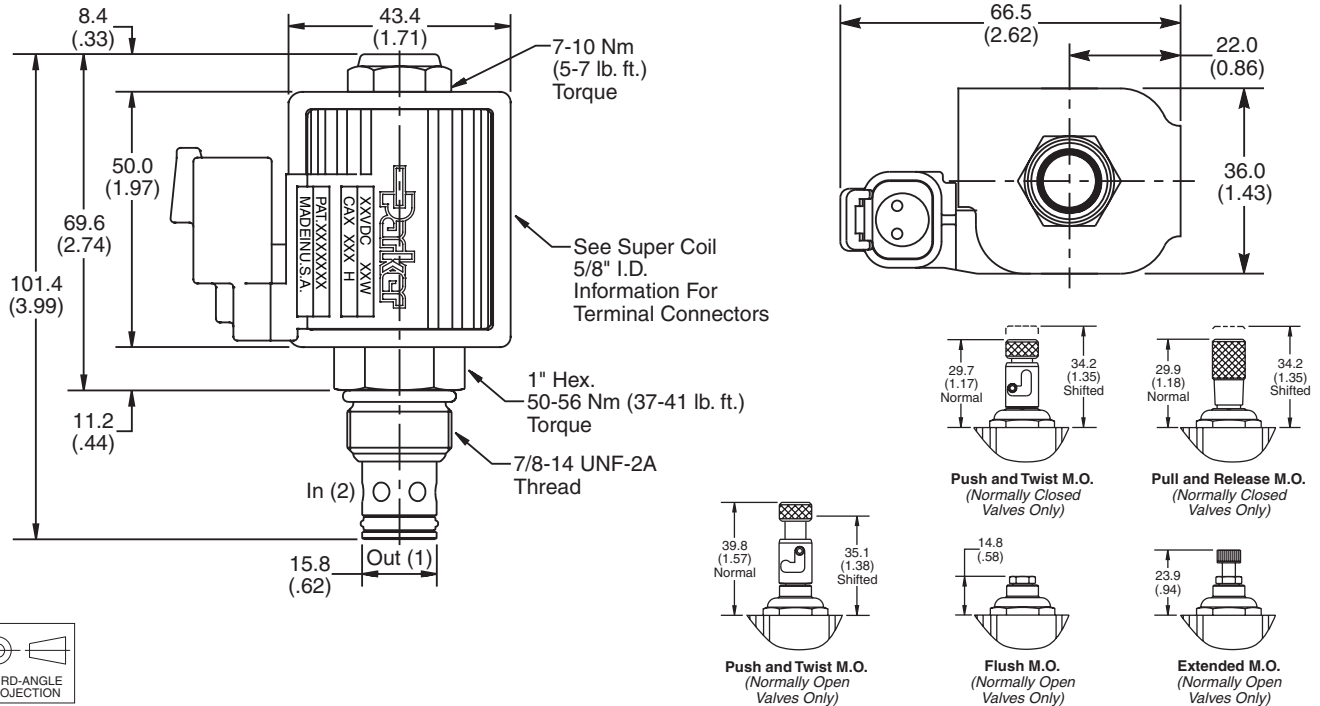

Ordering Information

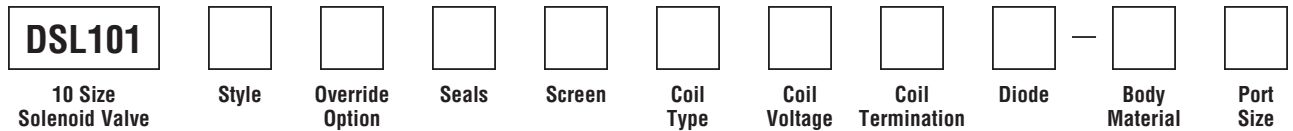

Code / Style	Diagram
C Normally Closed Metered reverse flow	
CH Normally Closed Metered reverse flow (Fast response)	
CHR Normally Closed Free reverse flow (Fast response)	
CR Normally Closed Free reverse flow	
N Normally Open Metered reverse flow	
NR Normally Open Free reverse flow	

Code	Override Options
Omit	None
E	Push Type with Extended Rod (N.O. Only)
M	Push Type with Flush Rod (N.O. Only)
P	Pull & Release (N.C. Only)
T	Push & Twist (N.C. & N.O.)

Code	Seals / Kit. No.
Omit	"D"-Ring / (SK10-2)
N	Nitrile / (SK10-2N)
V	Fluorocarbon / (SK10-2V)

Code	Screen
Omit	None
S	Screen

Code	Coil Type
Omit	Without Coil
SP*	Super Coil - 28 Watts

*Recommended

Code	Coil Voltage
Omit	Without Coil
D012	12 VDC
D024	24 VDC
A120	120/110 VAC, 60/50 Hz
A240	240/220 VAC, 60/50 Hz

SP* Coil	Coil Termination
Omit	Without Coil
C	Conduit With Leads
D	DIN Plug Face
A	Amp Jr. Timert†
S	Dual Spade†
L	Dual Lead Wire†
LS	Sealed Lead Wire†
H	Molded Deutsch†

*Recommended †DC Only

Code	Diode
Omit	None
R	Diode

Code	Body Material
Omit	Steel
A	Aluminum

Code	Port Size	Body Part No.
Omit	Cartridge Only	
4P	1/4" NPTF	(B10-2-*4P)
6P	3/8" NPTF	(B10-2-*6P)
8P	1/2" NPTF	(B10-2-*8P)
6T	SAE-6	(B10-2-*6T)
8T	SAE-8	(B10-2-*8T)
T8T	SAE-8	(B10-2-T8T)†
6B	3/8" BSPG	(B10-2-6B)†

* Add "A" for aluminum. omit for steel. † Steel body only.