

Parts List			
ITEM	QTY	PART NUMBER	DESCRIPTION
1	1	57XL-40N	40 MICRON FILL W/NYLON STRAINER
2	2	BF-16	1" NPT VENT
3	1	N_A4070	NAM WELDMENT ~65 1/2 lbs

AMP PARTS INCLUDE:  
 -ABK-340-C OR ABK-340-S MOUNTING KIT

NOTE:  
 -PLUG ALL PORTS FOR SHIPMENT

DATE	SYM.	DESCRIPTION	BY
2-18-15	F	REDUCE OAL BY .100	BPK
8-21-12	E	ADD SECOND VENT	BPK
6-1-12	D	INCREASED OAL BY 2.50	BPK
5-16-12	C	REVISED SUCTION PORTS	BPK
10-20-08	A	ADDED SUCTION PORT REINFORCEMENTS	BPK
REVISIONS			
10-23-06	N/A	SUPERSEDES MODEL A4070 DATED 10-26-2005	BPK

<b>AMERICAN MOBILE POWER</b> PH: (800) 634-8265 FAX: (765) 948-3403	DRAWING BY: BPKNIGHT	DESIGN FOR: <b>AMERICAN MOBILE POWER</b>	FILE NAME: A4070	
	COMPLETED: 10/23/2006		SHEET: 1 of 9	SHEET SIZE: B

4

3

2

1

B

B

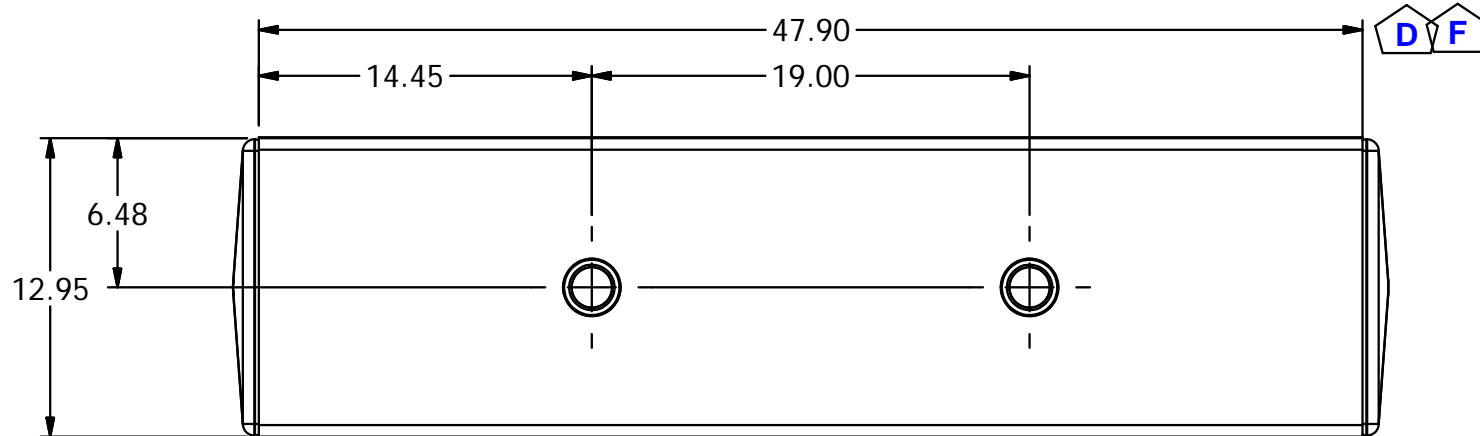
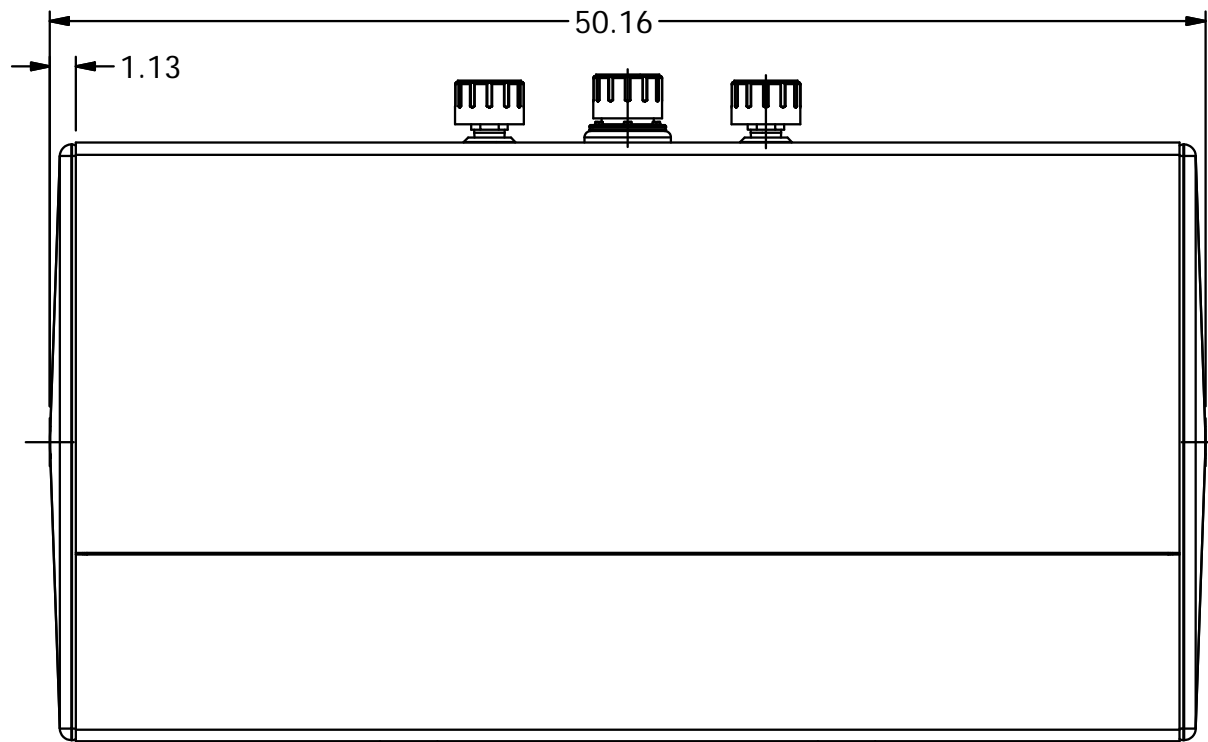
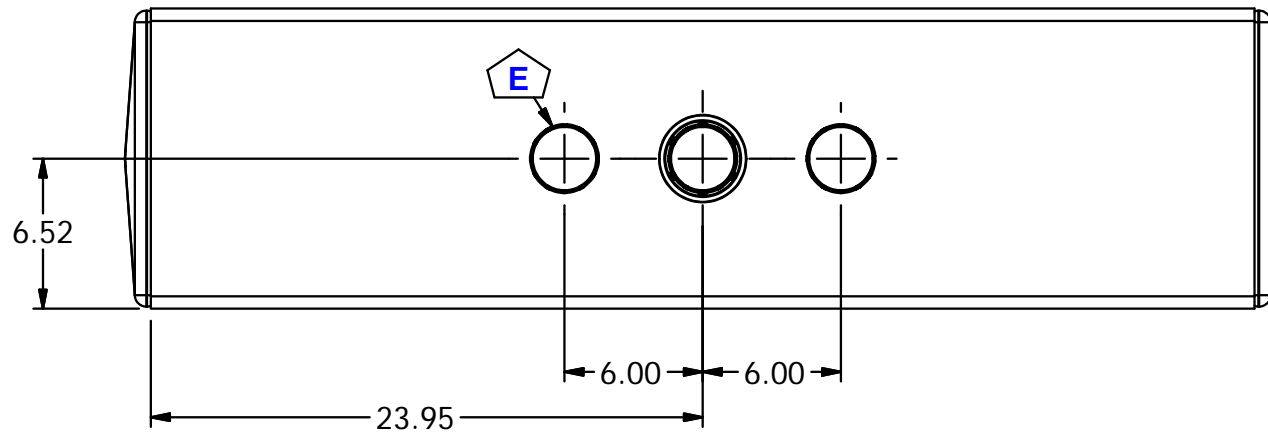
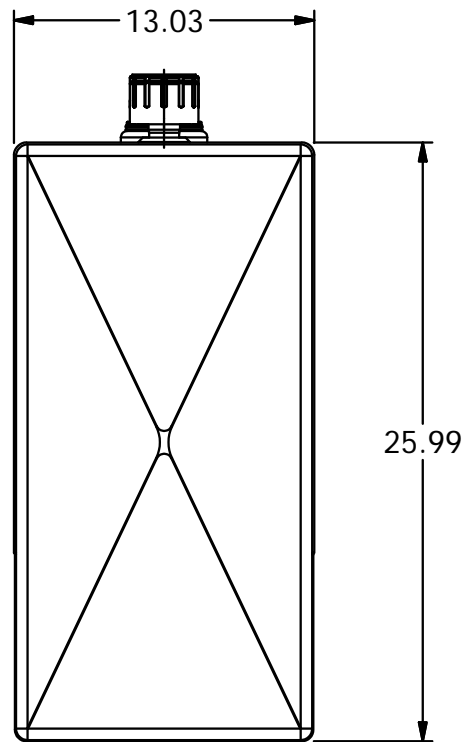

A

A

REVISIONS			
DATE	SYM.	DESCRIPTION	BY
2-18-15	F	REDUCE OAL BY .100	BPK
8-21-12	E	ADD SECOND VENT	BPK
6-1-12	D	INCREASED OAL BY 2.50	BPK

<b>AMERICAN MOBILE POWER</b> PH: (800) 634-8265 FAX: (765) 948-3403	DRAWING BY: BPKNIGHT	DESIGN FOR: AMERICAN MOBILE POWER	FILE NAME: A4070	
	COMPLETED: 10/23/2006		SHEET: 2 of 9	SHEET SIZE: B

4

3

2

1

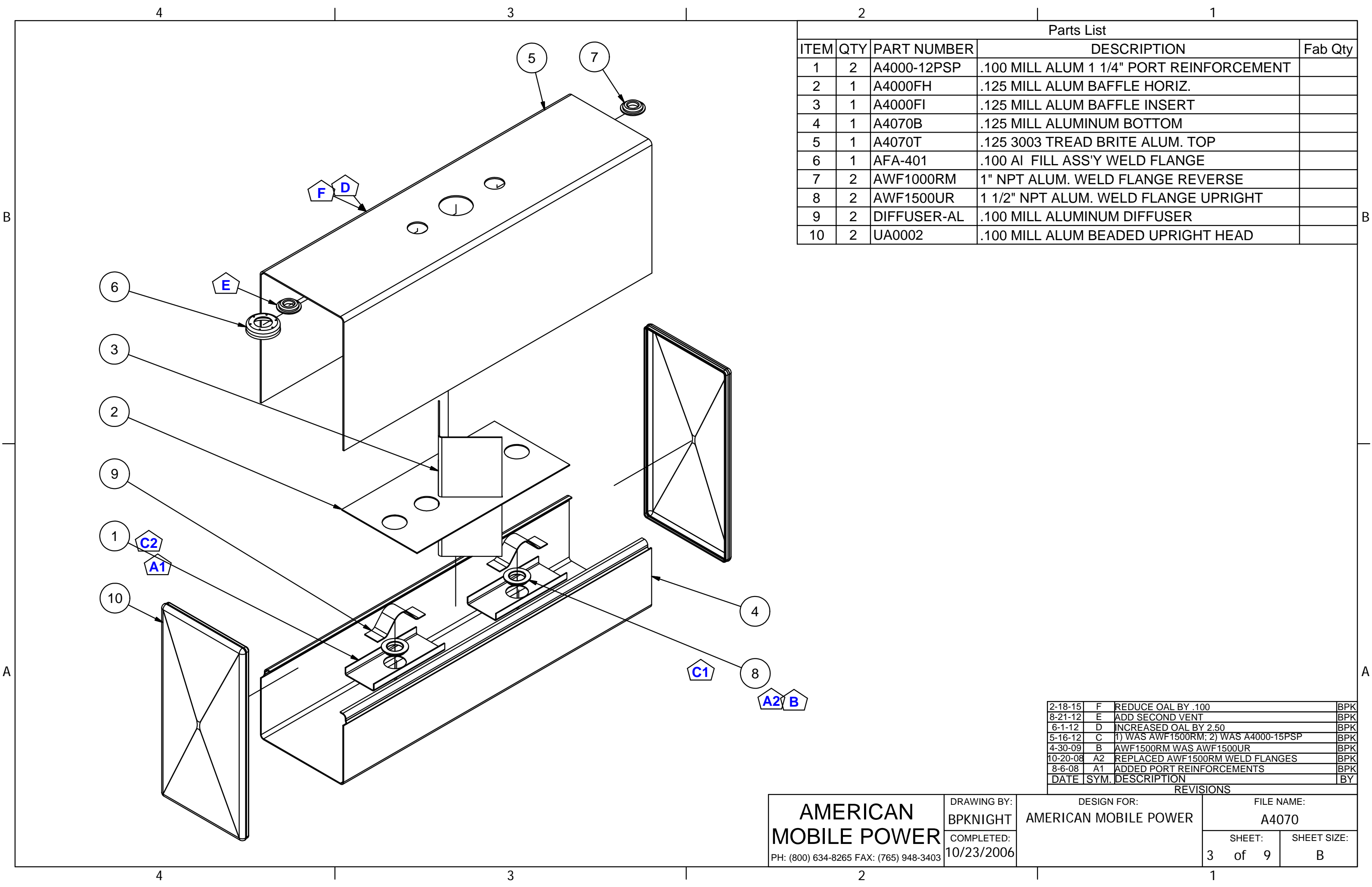

Parts List				
ITEM	QTY	PART NUMBER	DESCRIPTION	Fab Qty
1	2	A4000-12PSP	.100 MILL ALUM 1 1/4" PORT REINFORCEMENT	
2	1	A4000FH	.125 MILL ALUM BAFFLE HORIZ.	
3	1	A4000FI	.125 MILL ALUM BAFFLE INSERT	
4	1	A4070B	.125 MILL ALUMINUM BOTTOM	
5	1	A4070T	.125 3003 TREAD BRITE ALUM. TOP	
6	1	AFA-401	.100 AI FILL ASS'Y WELD FLANGE	
7	2	AWF1000RM	1" NPT ALUM. WELD FLANGE REVERSE	
8	2	AWF1500UR	1 1/2" NPT ALUM. WELD FLANGE UPRIGHT	
9	2	DIFFUSER-AL	.100 MILL ALUMINUM DIFFUSER	
10	2	UA0002	.100 MILL ALUM BEADED UPRIGHT HEAD	

DATE	SYM.	DESCRIPTION	BY
2-18-15	F	REDUCE OAL BY .100	BPK
8-21-12	E	ADD SECOND VENT	BPK
6-1-12	D	INCREASED OAL BY 2.50	BPK
5-16-12	C	1) WAS AWF1500RM; 2) WAS A4000-15PSP	BPK
4-30-09	B	AWF1500RM WAS AWF1500UR	BPK
10-20-08	A2	REPLACED AWF1500RM WELD FLANGES	BPK
8-6-08	A1	ADDED PORT REINFORCEMENTS	BPK

<b>AMERICAN MOBILE POWER</b> <small>PH: (800) 634-8265 FAX: (765) 948-3403</small>	DRAWING BY: BPKNIGHT	DESIGN FOR: <b>AMERICAN MOBILE POWER</b>	FILE NAME: A4070	
	COMPLETED: 10/23/2006		SHEET: 3 of 9	SHEET SIZE: B

REVISIONS