

American Wet Tank System

Model A3000 & A4000

Mounting Kit Contents: Part Number ASK-200

Qty	Description
4	Pre-drilled and powder coated chassis mounting angles
4	Pre-drilled rubber mounting pads
4	Two inch (2") plated compression springs
4	Cap screws - 5/8" - 11 x 4-1/2", grade 5
4	Ny-Loc nuts - 5/8" - 11
8	Plated flat washers - 5/8"

Materials Required To Complete Installation:

Qty	Description
8	Cap screws 1/2", grade 5 (length determined by installer)
8	Ny-Loc nuts - 1/2" diameter
16	1/2" washers

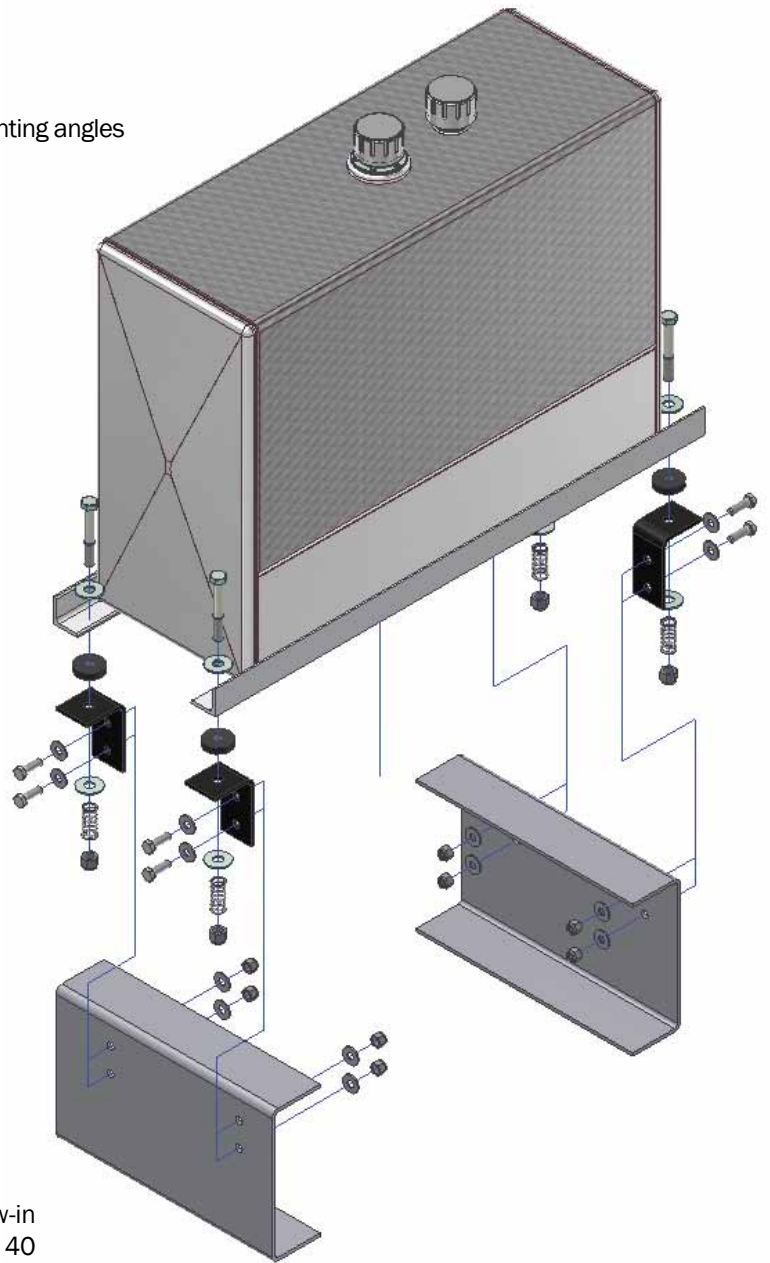

Pre-Packaged Kit Includes:

Steel or aluminum tank assembly with two 1-1/4" screw-in NPT bottom ports, filler/breather assembly including a 40 micron filter/breather cap (chain mounted), auxiliary vent, and the ASK-200 mounting kit.

This wet tank assembly has been designed for a dump trailer application using either a two or three line system.



American Wet Tank System Model A3000 & A4000

INSTRUCTIONS:

1. Position tank and base assembly on frame rails of the truck chassis as desired.

2. Position chassis mounting angles so that the double pre-drilled holes are positioned against the frame rail and the single ($11/16$ " hole is positioned upward against the tank mounting angles. (see diagram at right)

Note: The top of the mounting angle should be flush with the top of the chassis rail.

3. Using the pre-drilled mounting angles as a guide, mark both the frame rail and tank mounting angles. Chassis requires use of a $9/16$ " drill bit while the mounting angles require an $11/16$ " drill bit. Drill holes and bolt the four mounting angles into place.

4. Place tank assembly across frame with mounting rails lined up directly over top holes in mounting angles. Mark and drill using a $11/16$ " drill bit

5. Place rubber mounting pads on top of the four mounting angles. (see diagram at right)

Note: The rubber pads should be above the top of the frame rails.

6. Reposition tank over pads and angles, install bolts and springs as shown in exploded view. (see diagram at right)

7. National Pipe Thread port openings: (see diagram at right)
The American Wet Tank System is designed with two $1-1/4$ " NPT port openings in the bottom of the tank. The system allows either port to be used as a suction or return line.

The assembly may be plumbed for use as a two or three line system.

