

# American Wet Tank System

## Model A3070 & A4070

### Mounting Kit Contents: Part Number ABK-340

Qty	Description
1	Heavy duty mounting base panel
2	2" wide strap assemblies including (4) ny-loc nuts w/ springs
4	13"x 2"x 1" rubber mounting pads
1	ASK-200 frame mounting kit

### Materials Required To Complete Installation:

Qty	Description
8	Cap screws 1/2", grade 5 (length determined by installer)
8	Ny-loc nuts - 1/2" diameter
16	1/2" washers

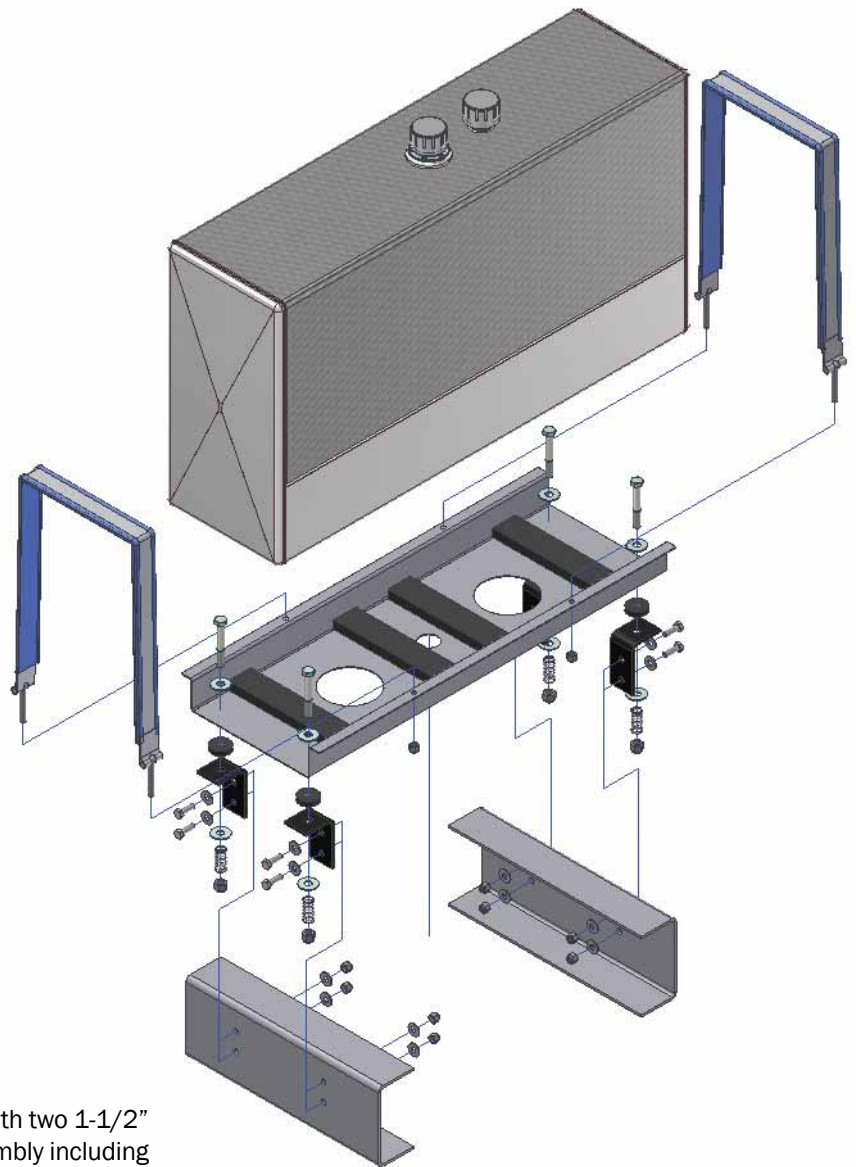

### Pre-Packaged Kit Includes:

Steel or aluminum tank assembly (70 gallon) with two 1-1/2" screw-in NPT bottom ports, filler/breather assembly including a 40 micron filter/breather cap (chain mounted), auxiliary vent, and the ABK-340 mounting base kit.

This wet tank assembly has been designed for use as a two or three line system.



# American Wet Tank System Model A3070 & A4070

## INSTRUCTIONS:

1. Position base panel on frame rails of the truck chassis as desired.
2. Position chassis mounting angles so that the double pre-drilled holes are positioned against the frame rail and the single (11/16") hole is positioned upward against the tank mounting base panel. (see diagram at right)

*Note: The top of the mounting angle should be flush with the top of the chassis rail.*

3. Using the pre-drilled mounting angles as a guide, mark both the frame rail and tank mounting base panel. Chassis requires use of a 9/16" drill bit while the mounting base requires an 11/16" drill bit. Drill holes and bolt the four mounting angles into place. (see diagram at right)

4. Next, place base panel over angles and install bolts and springs as shown in exploded view. (see diagram at right)

*Note: The rubber pads should be above the top of the frame rails.*

5. Place the (4) 13" x 2" x 1" rubber mounting pads on the base panel as shown in exploded view.

Center tank on base panel, install strap assemblies. (see diagram at right)

Rubber will conform to tank bottom as straps are tightened.

