

Effective: HY25-1400-M1/US June 2024  
Supersedes: HY25-1400-M1/US May 2024  
Supersedes: HY25-1810-M1/US August 2023

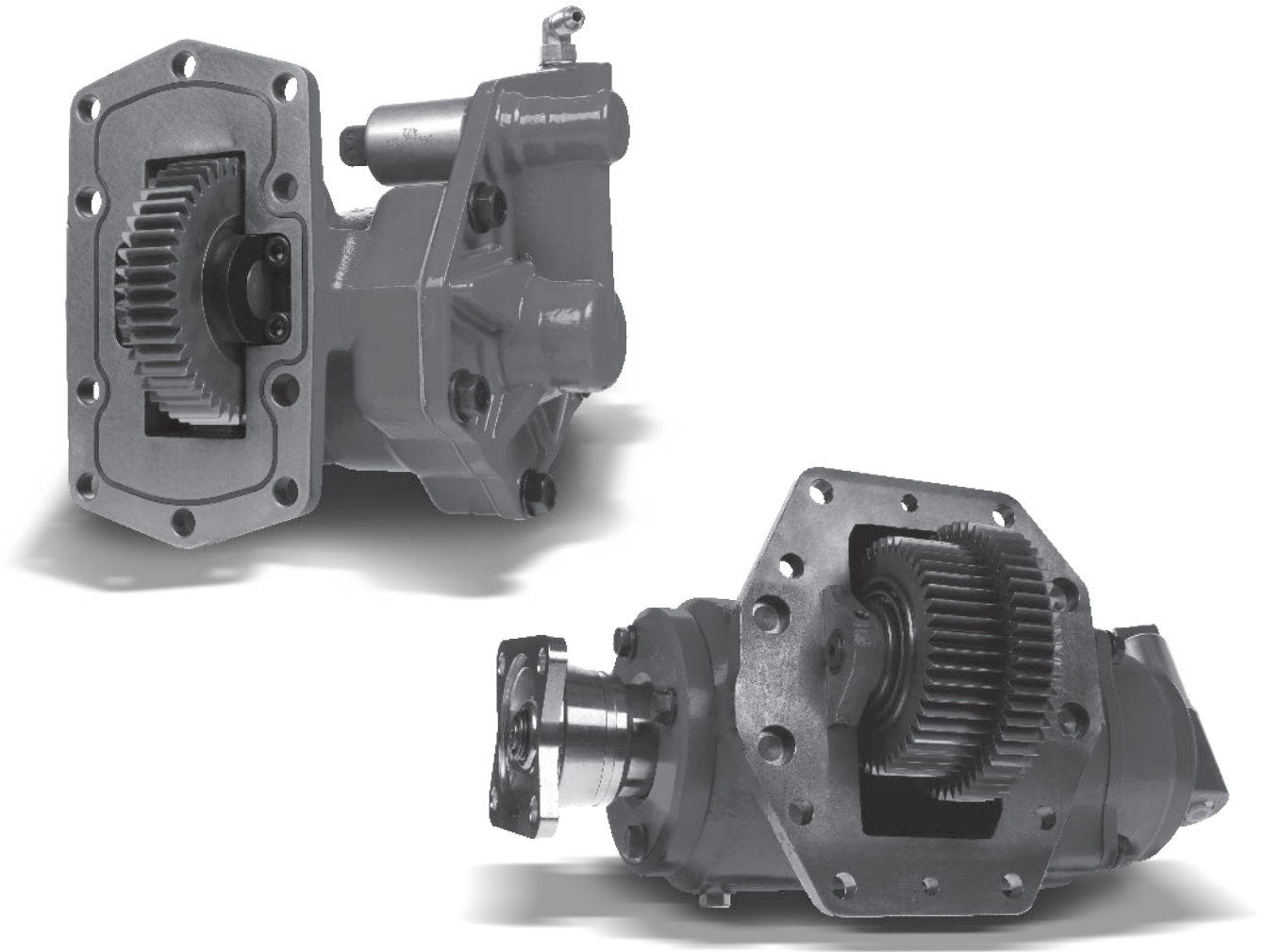

# Power Take-Offs Owner's Manual

## 210, 810 Series



ENGINEERING YOUR SUCCESS.



### **WARNING – User Responsibility**

FAILURE OR IMPROPER SELECTION OR IMPROPER USE OF THE PRODUCTS DESCRIBED HEREIN OR RELATED ITEMS CAN CAUSE DEATH, PERSONAL INJURY AND PROPERTY DAMAGE.

This document and other information from Parker Hannifin Corporation, its subsidiaries and authorized distributors provide product or system options for further investigation by users having technical expertise.

The user, through its own analysis and testing, is solely responsible for making the final selection of the system and components and assuring that all performance, endurance, maintenance, safety and warning requirements of the application are met. The user must analyze all aspects of the application, follow applicable industry standards, and follow the information concerning the product in the current product catalog and in any other materials provided from Parker or its subsidiaries or authorized distributors.

To the extent that Parker or its subsidiaries or authorized distributors provide component or system options based upon data or specifications provided by the user, the user is responsible for determining that such data and specifications are suitable and sufficient for all applications and reasonably foreseeable uses of the components or systems.

### **Offer of Sale**

The items described in this document are hereby offered for sale by Parker Hannifin Corporation, its subsidiaries or its authorized distributors. This offer and its acceptance are governed by the provisions stated in the "Offer of Sale".



**WARNING:** This product can expose you to chemicals including Lead and Lead Compounds, and Di(2-ethylhexyl)phthalate (DEHP) which are known to the State of California to cause cancer and birth defects or other reproductive harm. For more information go to [www.P65Warnings.ca.gov](http://www.P65Warnings.ca.gov)

© Copyright 2024, Parker Hannifin Corporation, All Rights Reserved

**Table of Contents**

**General Information**

Foreword..... 1  
 Safety Information ..... 1-3  
 PTO Safety Label Instructions ..... 3  
 Pump Bracketing Best Practices ..... 4-5  
 Function of Auxiliary Power Shafts..... 6  
 Spicer® Universal Joint Engineering Data..... 7  
 PTO Shifting Procedure & Precautions ..... 8  
 PTO Maintenance..... 9

**210 Series Installation Instructions – Ford TorqShift® 10R140 Transmission  
 Super Duty F-250/350/450/550/600 MY2020+**

**Transmission Overview**

TorqShift® 10R140 Transmission Stationary Elevated Idle Control (SEIC)  
 PTO Operating Modes ..... 12-16

**Installation Instructions**

Super Duty F-250/350/450/550/600 – MY2020+ – ALL In-Cab PTO Switch Installation ..... 17-18  
 PTO Installation – Overview ..... 19  
 PTO Installation – Pre-Work ..... 19-22  
 PTO Installation..... 23-25  
 Transmission/PTO Electrical Operation..... 25

**Installation Sketches**

Wiring Installation (Shift Option B) Super Duty F-250/350/450/550/600 – MY2020+ w/o Electronic Overspeed  
 Control (EOC) 210 Series (SK-658) ..... 26  
 Wiring Installation (Shift Option K) Super Duty F-250/350/450/550/600 – MY2020+ w/ Electronic Overspeed  
 Control (EOC) 210 Series (SK-660) ..... 27  
 Wiring Installation PTO to Ford Super Duty F-250/350/450/550/600 – MY2020+ w/o Electronic Overspeed  
 Control (EOC) 210 Series (SK-656 Rev B) ..... 28-29  
 Wiring Installation to Ford Super Duty F-250/350/450/550/600 – MY2020+ w/ Electronic Overspeed  
 Control (EOC) 210 Series (SK-656 Rev B) ..... 30-31  
 Wiring Installation Chart PTO to Ford Super Duty F-250/350/450/550/600 – MY2020+  
 w/ and w/o Electronic Overspeed Control (EOC) 210 Series ..... 32-33

**810 Series Installation Instructions – Ford TorqShift® HD 10R140 Transmission  
 Medium Duty F-650/F-750 MY2024+**

**Transmission Overview**

TorqShift® HD 10R140 Transmission – Stationary Elevated Idle Control (SEIC)  
 PTO Operating Modes ..... 36-43

**Installation Instructions**

PTO Installation – Overview ..... 44  
 PTO Installation..... 44-47  
 Checking Backlash ..... 48  
 Transmission/PTO Electrical Operation..... 49

Continued on Next Page

**Table of Contents**

**810 Series Installation Instructions – Ford TorqShift® HD 10R140 Transmission  
Medium Duty F-650/F-750 MY2024+ (Continued)**

**Installation Sketches**

Wiring Installation (Shift Option B) F-650/F-750 6.7L Diesel MY2024+ w/o Electronic Overspeed  
Control (EOC) 810 Series (SK-685 Rev B) ..... 50

Wiring Installation Chart (Shift Option B) F-650/F-750 6.7L Diesel MY2024+ w/o Electronic Overspeed  
Control (EOC) 810 Series (SK-685 Rev B) ..... 51

Wiring Installation (Shift Option K) F-650/F-750 6.7L Diesel MY2024+ w/ Electronic Overspeed  
Control (EOC) 810 Series (SK-660 Rev B) ..... 52

Wiring Installation Chart (Shift Option K) F-650/F-750 6.7L Diesel MY2024+ w/ Electronic Overspeed  
Control (EOC) 810 Series (SK-660 Rev B) ..... 53

Wiring Installation (Shift Option B) F-650/F-750 6.7L Diesel MY2024+ w/o Electronic Overspeed  
Control (EOC) 810 Series (SK-656 Rev B) ..... 54-55

Wiring Installation (Shift Option K) F-650/F-750 6.7L Diesel MY2024+ w/ Electronic Overspeed  
Control (EOC) 810 Series (SK-656 Rev B) ..... 56-57

**810 Series Appendix**

Appendix A: Resistor Tables ..... 58-59

Appendix B: SEIC/PTO: PTO Modes Circuit Descriptions (Diesel) ..... 60

Offer of Sale ..... 61-63

**Foreword**

This booklet will provide you with information on correct installation of Chelsea® Power Take-Offs (PTOs). Proper installation and setup procedures can help you get additional and more profitable hours from your truck equipment and components.

It is important that you be sure that you are getting the right transmission and PTO combination when you order a new truck. A mismatched transmission and PTO combination can result in unsatisfactory performance of your auxiliary power system from the start.

If you have questions regarding correct PTO and transmission combination, please contact your local Chelsea® representative. They can help you select the properly matched components to ensure correct and efficient applications.

**Safety Information**

These instructions are intended for the safety of the system designer, installer, operator, and supporting personnel. If you have any additional questions after reading the instructions below, please reach out to your local Chelsea representative.

**General Safety Information****To prevent injury to yourself and/or damage to the equipment:**

- Carefully read all owner's manuals, service manuals, and/or other instructions.
- Always follow procedures using proper tools and safety equipment.
- Ensure proper training is received prior to attempting to install equipment.
- Always block any raised or moving device that may injure a person working on or under a vehicle.
- Never work alone while under a vehicle, repairing equipment, or maintaining equipment.
- Always use proper components in applications for which they are approved.
- Never use worn-out or damaged components.
- Never operate the controls of the PTO or other driven equipment from any position that could result in getting caught in the moving machinery.

**Proper Matching of PTO**

**WARNING:** A Power Take-Off must be properly matched to the vehicle transmission and to the auxiliary equipment being powered. An improperly matched Power Take-Off could cause severe damage to the vehicle transmission, the auxiliary driveshaft, and/or to the auxiliary equipment being powered. **Damaged components or equipment could malfunction causing serious personal injury to the vehicle operator or to others nearby.**

**To avoid personal injury and/or equipment damage:**

- Always refer to Chelsea's catalogs, literature, and owner's manuals.
- Follow Chelsea's recommendations when selecting, installing, repairing, or operating a PTO.
- Never attempt to use a PTO that is not specifically recommended by Chelsea for the vehicle, transmission, and application.
- Always match the PTO's specified output capabilities with the requirements of the equipment to be powered.
- Never exceed the maximum speed listed in Chelsea's Applications Catalog.



This symbol warns of possible personal injury.

## Safety Information (Continued)

### Cold Weather Operation of PowerShift PTO

 **WARNING:** During extreme cold weather operation [32°F (0°C) and lower], a disengaged PowerShift Power Take-Off can momentarily transmit high torque that will cause unexpected output shaft rotation. This is caused by the high viscosity of the transmission oil when it is extremely cold. As slippage occurs between the Power Take-Off clutch plates, the oil will rapidly heat up, and the viscous drag will quickly decrease.

The rotation of the PTO's output shaft could cause unexpected movement of the driven equipment resulting in serious personal injury, death, or equipment damage.

#### To avoid personal injury or equipment damage:

- Driven equipment must have separate controls.
- The driven equipment must be left in the disengaged position when not in operation.
- Do not operate the driven equipment until the vehicle is allowed to warm up.

### Rotating Auxiliary Driveshafts



- Rotating auxiliary driveshafts can cause serious injury or death by snagging clothes, skin, hair, hands etc.
- Do not go under the vehicle when the engine is running.
- Do not work on or near an exposed shaft when the engine is running.
- Shut off the engine before working on the PTO or driven equipment.
- Exposed rotating driveshafts must be guarded.

### Guarding Auxiliary Driveshafts

 **WARNING:** We strongly recommend that a Power Take-Off and a directly mounted pump be used to eliminate the auxiliary driveshaft whenever possible. If an auxiliary driveshaft is used and remains exposed after installation, it is the responsibility of the vehicle designer to specify guard(s) and PTO installer to install guard(s).

### Using Set Screws

 **WARNING:** Auxiliary driveshafts may be installed with either recessed or protruding set screws. If you choose a square head set screw, you should be aware that it will protrude above the hub of the yoke and may be a point where clothes, skin, hair, hands etc., could be snagged. A socket head set screw, which may not protrude above the hub of the yoke, does not permit the same amount of torquing as does a square head set screw. Also, a square head set screw, if used with a lock wire, will prevent loosening of the screw caused by vibration. Regardless of the choice made with respect to a set screw, an exposed rotating auxiliary driveshaft must be guarded.

### Important: Safety Information and Owner's Manual

 **WARNING:** Chelsea Power Take-Offs are packaged with warning labels, safety information decals, instructions, and an owner's manual. These items are located in the envelope with the PTO mounting gaskets. Also, safety information and installation instructions are packaged with some individual parts and kits. Be sure to read the owner's manual and safety information before installing or operating the PTO. Always install the safety information decals according to the instructions provided. Place the owner's manual in the vehicle glove compartment.

 This symbol warns of possible personal injury.

**Safety Information (Continued)**

**! WARNING: Operating the PTO with the Vehicle in Motion**

Some Power Take-Offs may be operated when the vehicle is in motion. PTOs must be properly selected to operate at highway speeds, correctly matched to the vehicle's transmission, as well as the requirements of the driven equipment.

If in doubt about the PTO specifications and capabilities, avoid operating the PTO when the vehicle is in motion. Improper application and/or operation can cause serious personal injury as well as premature failure of the vehicle, driven equipment, and PTO.

Always remember to disengage the PTO when the driven equipment is not in operation.

**PTO Safety Label Instructions**

1. The two black and orange on white 5" x 7" pressure sensitive vinyl labels (PN 379274) must be placed one on each side of the vehicle in a position that would be **HIGHLY** visible to anyone that would go under the truck near the PTO rotating shaft. If the vehicle is to be painted after these labels are installed, cover them with two blank masking covers. Remove the masking covers after painting.
2. Place the one black and orange on white 3.5" x 5" pressure sensitive vinyl label (PN 379275) on the sun visor nearest the operator of the vehicle.
3. Place the one red and white with black lettering 3.5" x 7" pressure sensitive vinyl label (PN 379915) on the sun visor next to the above label (PN 379275).
4. Place the one white and black heavy-duty card (PN 379276) in the vehicle glove box in a position highly visible to the operator. For example, try to place this card on top of whatever may be in the glove box.

If you require labels, please order part number 328946X at no charge from your local Chelsea representative or send request direct to:

**Parker-Hannifin Corporation**  
 Chelsea Products Division  
 8225 Hacks Cross Road  
 Olive Branch, MS 38654

Phone: +1 (662) 895-1011  
 Email: [chd\\_support@support.parker.com](mailto:chd_support@support.parker.com)

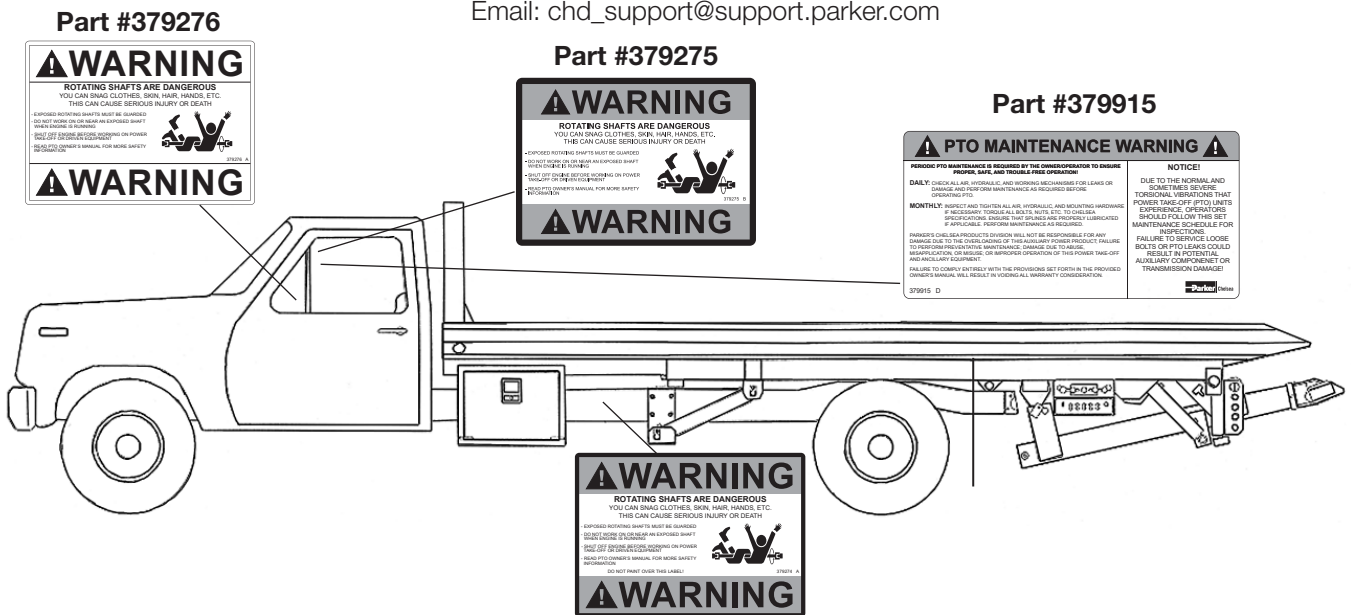

**! This symbol warns of possible personal injury.**

## Pump Bracketing Best Practices

With changes in emissions standards, truck systems are experiencing more vibration and vibration related issues. Due to the changes, Parker Chelsea finds it necessary to discuss the importance of pump bracketing and the effects it can have on the mounted PTO. Parker Chelsea has made updates to the pump bracketing support guidelines listed in all PTO Owner's Manuals. This bulletin will discuss the importance of bracketing and the best practices to keep in mind when mounting a pump.

**Please note, due to the high variance of applications and the increasing severity of vibration found in modern diesel engines Parker Chelsea's pump bracketing best practices cannot consider all factors affecting the PTO and Pump bracketing. Please use the following information as a GUIDELINE ONLY when installing pump bracketing.**

### Potential causes of bracket failures that can damage a PTO and/or Pump:

- Excessive preload from poor bracket design, fabrication, and installation.
- Excessive vibration from the vehicle's normal driving operation leading to high loads on the PTO bolts.
- Torque spikes from extreme vibration could be intense enough to break bolts in the bracketing. The worst cases occur while the truck is operating at highway speeds.

**⚠ In addition to the conditions listed above, Chelsea requires the use of support brackets in all applications to ensure the Maximum Bending Moment (MBM) of the PTO and pump assembly is not exceeded. Exceeding the MBM can result in damage to PTO, transmission, driven equipment, and/or personnel. It is the responsibility of the installer to ensure that adequate support is implemented. All applications are unique and it is important to consider all parameters in designing a proper support bracket.**

Use **CAUTION** to ensure the support bracket does not pre-load PTO and pump mounting. Prior to mounting, pumps must be fully supported by a jack until it is properly secured with support bracket(s). This will ensure the PTO is not being stressed by the bracket. Brackets must be designed to adequately eliminate deflections from weight, vibration, and truck movements.

PTO warranty will be voided if support brackets are not used when one of the following conditions apply:

- Combined weight of the pump, fittings, hoses, and oil exceeds 40 lbs [18.14 kg]
- Combined length of the PTO and pump is greater than 18 inches [45.72 cm]
- Pumps should have a support bracket when mounted onto a on a non-extended shaft PTO
- Extended Shaft PTOs: Please see applicable owner's manual for additional guidance

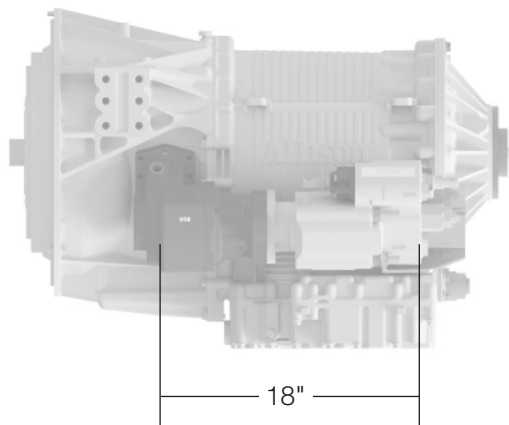

To ensure proper bracketing, brackets must attach at two or more transmission bolt locations as well as two or more pump (bolt) locations. Please reach out to your transmission manufacturer for proper bracket mounting locations.

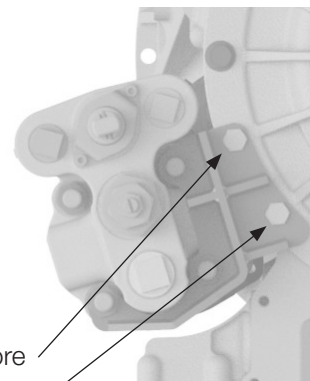

**⚠ This symbol warns of possible personal injury.**

## Pump Bracketing Best Practices (Continued)

An installed PTO/Pump bracket needs to be properly aligned. Misalignment in the X direction (**Fig. 1**) is substantially more impactful than misalignment in the Y or Z direction (**Fig. 2**). To prevent this, installing a fixture-built bracket is preferred. This allows the PTO/Pump to be installed prior to making the final welds on the bracket.

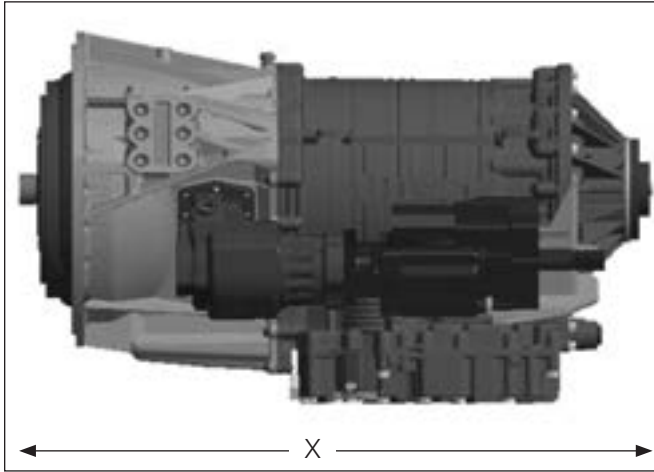

Figure 1

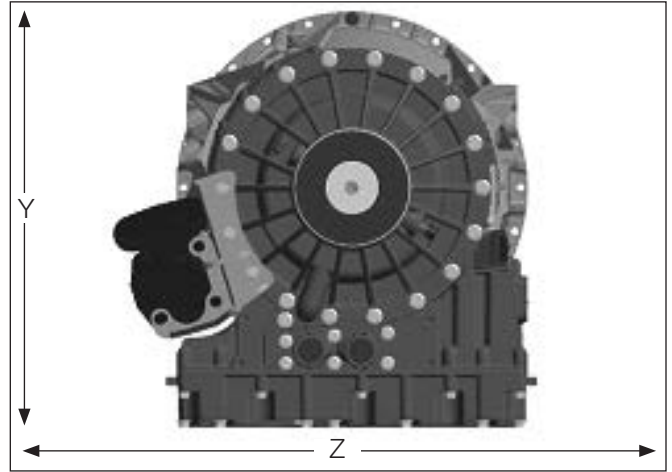
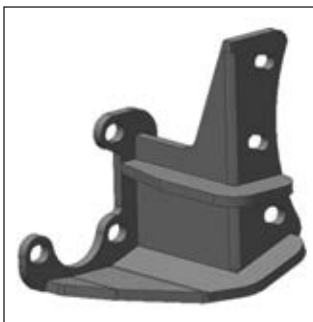

Figure 2

- The PTO/Pump should be treated as engine mounted components and installed per the engine manufacturer's published guidelines for engine mounted components when applicable.
- For proper bracketing, attach the bracket at two or more transmission bolt locations and two or more pump locations. Whenever possible, three attachment points in either (or both) locations is suggested. Please contact the transmission manufacturer for proper bracket mounting locations.
- Brackets should contain at least one gusset, preferably two. The gussets should be 3/8" thick and at least 1" deep. 3/8" steel is suggested particularly with gussets and in areas with reduced cross section.
- Please refer to the transmission and pump manufacturer's approved pump bracket support locations.



These best practices should be followed for optimal results. Please note, each bracketing situation is different so this bulletin must only be used as a guideline. For further bracketing assistance please refer to your PTO Owner's Manual or contact your Chelsea PTO representative for questions.

**If you have any technical questions, contact us at:**

**Phone: +1 (662) 895-1011**

**Email: [chd\\_support@support.parker.com](mailto:chd_support@support.parker.com)**

## Function of Auxiliary Power Shafts

An auxiliary power shaft transmits torque from the power source to the driven accessory. The shaft must be capable of transmitting the maximum torque and RPM required of the accessory, plus any shock loads that develop.

An auxiliary power shaft operates through constantly relative angles between the power source and the driven accessory. Therefore, the length of the auxiliary power shaft must be capable of changing while transmitting torque. This length change, commonly called slip movement, is caused by movement of the power train due to torque reactions and chassis deflections.

Joint operating angles are very important in an auxiliary power joint application. In many cases, the longevity of a joint is dependent on the operating angles in the chart below.

<b>SPICER® UNIVERSAL JOINT OPERATING ANGLES</b>			
<b>Prop. Shaft RPM</b>	<b>Max. Normal Operating Angle</b>	<b>Prop. Shaft RPM</b>	<b>Max. Normal Operating Angle</b>
3000	5° 50'	1500	11° 30'
2500	7° 00'	1000	11° 30'
2000	8° 40'	500	11° 30'

Above based on angular acceleration of 100 RAD/SEC<sup>2</sup>

This information is limited to 1000 through 1310 series applications. For applications requiring a series larger than 1310, please contact your driveline specialist.

### Determining Shaft Type

- 1) Solid or tubular?
  - a) In applications requiring more than 1000 RPM or where the application necessitates a highly balanced auxiliary power shaft, a tubular shaft should be used.
  - b) Spicer's solid shaft auxiliary power joints are designed for intermittent service at 1000 or less RPM. Examples include driving of small hydraulic pumps, low speed product pumps, and winches.
- 2) Joint Series should be determined using the chart on the following page.

 **WARNING:** direct customer to driveline manuf/spec.

**Spicer® Universal Joint Engineering Data**

<b>Joint Series</b>	<b>1000</b>	<b>1100</b>	<b>1280</b>	<b>1310</b>
<b>Torque Rating</b>				
Automotive (Gas or Diesel Engine) lb-ft Continuous	50	54	95	130
<b>Tubing</b>				
Diameter	1.750"	1.250"	2.500"	3.000"
Wall Thickness	.065"	.095"	.083"	.083"
W = Welded S = Seamless	W	S	W	W
<b>Flange Diameter</b> (Swing Diameter)				
Rectangular Type	3.500"	3.500"	3.875"	3.875"
<b>Bolt Holes</b> - Flange Yoke				
Circle	2.750"	2.750"	3.125"	3.125"
Diameter	.312"	.312"	.375"	.375"
Number	4	4	4	4
Male Pilot Dia.	2.250"	2.250"	2.375"	2.375"
<b>Distance Across Lugs</b>				
Snap Ring	2.188"	2.656"	3.469"	3.469"
Construction	2.188"	2.656"	3.469"	3.469"
<b>Bearing Diameter</b>	.938"	.938"	1.062"	1.062"

<b><sup>1,2</sup> Maximum Operating Speed for Tube or Solid Shaft Diameter and Length</b>					
Tube	RPM - Revolutions per Minute				
OD x Wall Thickness (Joint Type)	<b>500</b>	<b>1000</b>	<b>1500</b>	<b>2000</b>	<b>2500</b>
1.750" x .065" (Welded)	117"	82"	67"	58"	52"
1.250" x .095" (Seamless)	91"	64"	52"	45"	40"
2.500" x .083" (Welded)	122"	87"	70"	62"	55"
3.000" x .083" (Seamless)	-	-	-	85"	76"
Solid Shaft	RPM - Revolutions per Minute				
Diameter	<b>500</b>	<b>1000</b>	<b>1500</b>	<b>2000</b>	<b>2500</b>
.750"	60"	42"	35"	30"	27"
.812"	62"	44"	36"	31"	28"
.875"	65"	46"	37"	32"	29"
1.000"	69"	49"	40"	35"	31"
1.250"	77"	55"	45"	39"	35"

<sup>1</sup> The numbers expressed above represent the maximum installed length for tubing or solid shaft in both two joint assemblies and joint shaft applications.

<sup>2</sup> Please contact your Chelsea representative for applications with speeds below 500 RPM and over 2500 RPM.

 **WARNING:** direct customer to driveline manuf/spec.

## **PTO Shifting Procedure & Precautions**

**CAUTION:** This vehicle is equipped with a Power Take-Off. Shut engine off before working on the Power Take-Off or getting below the vehicle. Consult the operating instructions before using the PTO (See sun visor).

POWER TAKE-OFF OPERATION — VEHICLE STATIONARY

### **Automatic Transmission with PowerShift PTO**

Engage the PTO with the engine at idle speed.

**NOTE:** PowerShift PTO: The engine must be at idle or below 1000 RPM when the PTO is engaged. See the transmission manufacturer's instructions for special procedures.

### **IMPORTANT:**

**Failure to follow the proper shifting or operating sequences will result in premature PTO failure with possible damage to other equipment.**

 **WARNING:** Cold Weather Operation of PowerShift PTO

During extreme cold weather operation [32°F (0°C) and lower], a disengaged PowerShift Power Take-Off can momentarily transmit high torque that will cause unexpected output shaft rotation. This is caused by the high viscosity of the transmission oil when it is extremely cold. As slippage occurs between the Power Take-Off clutch plates, the oil will rapidly heat up and the viscous drag quickly decreases.

The rotation of the PTO's output shaft could cause unexpected movement of the driven equipment, resulting in serious personal injury, death, or equipment damage.

### **To avoid personal injury or equipment damage:**

- Driven equipment must have separate controls.
- Driven equipment must be left in the disengaged position when not in operation.
- Driven equipment must not be operated until the vehicle is allowed to warm up.

 This symbol warns of possible personal injury.

---

## Power Take-Off Maintenance

Due to the normal and sometime severe torsional vibrations that PTOs experience, operators should follow a set maintenance schedule for inspections. Failure to service loose bolts or PTO leaks could result in potential auxiliary Power Take-Off or transmission damage.

Periodic PTO maintenance is required by the owner/operator to ensure proper, safe, and trouble-free operation.

**Daily:** Check all air, hydraulic, and working mechanisms before operating PTO and perform maintenance as required.

**Monthly:** Inspect for possible leaks and tighten all air, hydraulic, and mounting hardware if necessary. Torque all bolts, nuts, etc., to Chelsea's specifications. If applicable, ensure that splines are properly lubricated. Perform maintenance as required.

With regards to the direct mounted pump splines, the PTO requires the application of a specially formulated anti-fretting grease. This grease must be specified for both high pressure and high temperature applications. The addition of the grease has been proven to reduce the effects of torsional vibrations, which result in fretting corrosion on the PTO's internal splines as well as the pump's external splines. Fretting corrosion appears as a rusting and wearing of the pump shaft splines. Severe duty applications, which require long PTO running times and high torque, may require more frequent regreasing. Continuous duty applications with light loads require frequent regreasing due to the higher number of running hours, an example of this is utility trucks. It is important to note that service intervals will vary for every application and they are the responsibility of the end user of the product. Chelsea also recommends that you consult your pump's owner's manual and technical services for their maintenance guidelines. Fretting corrosion is caused by many factors and without proper maintenance; the anti-fretting grease can only reduce its effects on components.

Chelsea offers anti-fretting grease to our customers in two package sizes:

- 5/8 fluid ounce tube (PN 379688) - Provided with PTO where applicable
- 14-ounce grease cartridge (PN 379831)

**Warranty: Failure to comply entirely with the provisions set forth in the appropriate owner's manual will result in voiding of warranty consideration.**

 This symbol warns of possible personal injury.



# 210 Series

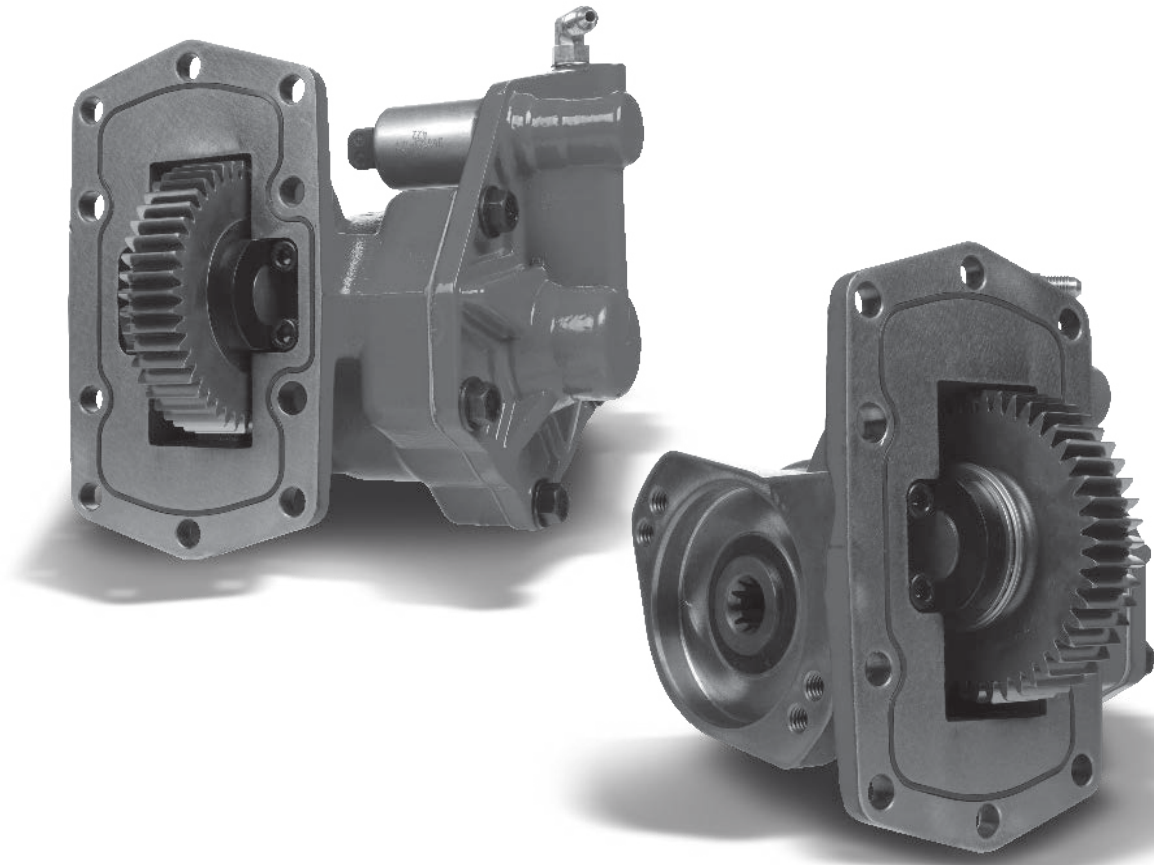

## FORD TorqShift® 10R140 Transmission

**Super Duty F-250/350/450/550/600  
Diesel/Gas  
MY2020+**

## TorqShift® 10R140 Transmission – Stationary Elevated Idle Control (SEIC) PTO Operating Modes

### Models Affected

F-250/350/450/550/600 Super Duty  
Diesel/Gas  
Starting MY2020

### General System Behavior

Purpose to explain functions of the (SEIC) system as well as Power Take-Off (PTO) operating modes. Always reference [fordbbas.com](http://fordbbas.com) for the most up to date information.

### Overview – SEIC and Transmission PTO

- A powertrain control module (PCM) strategy that provides elevated engine speed to drive auxiliary commercial equipment such as hydraulic pumps, generators, and air compressors; or maintain vehicle battery charge under extreme electrical demands.
- SEIC is standard in all PCMs for Super Duty Trucks.

### Customer Access Wires for SEIC and VSO/CTO/PARK Signals

- Located in cabin, tagged and bundled behind the passenger side kick Panel. Pass thru wires are in the same location.
- The final stage manufacturer or up-fitter is required to supply the customer interface equipment.

### Transmission PTO Gear and Port

- Available on F-250/350/450/550/600
- Available for TorqShift® automatic transmissions by ordering “Transmission Power Take-Off Provision”.
- The PTO gear is direct-splined to the torque converter cover and thus able to deliver power any time the engine is running (i.e., no internal PTO clutch).
- NEVER use any sealer, especially silicone-based, on the PTO port gasket.
- The PTO gear delivers up to 300 lb-ft [406 N-m] of torque (w/ Diesel) and 250 lb-ft [338 N-m] of torque (w/ 6.2L and 7.3L Gas) to the Chelsea PTO, and can manage the heat of 60 HP (Diesel) and 40 HP (Gas) continuously. Higher horsepower can be delivered, but for shorter durations depending on the amount of power required.

### Maximum Loads at PTO (Summary)

Engine	Stationary Mode	Mobile Mode	*Split Shaft Mode
6.7L Diesel	300 lb-ft [406 N-m]	150 lb-ft [203 N-m]	N/A
7.3L Gas	250 lb-ft [338 N-m]	125 lb-ft [169 N-m]	–
6.2L Gas	250 lb-ft [338 N-m]	115 lb-ft [155 N-m]	–

\*We presently do not offer a Split Shaft option for this platform. Please reference Ford's Body Builder website for additional Split Shaft information.

Please reference the most current edition of Ford's Body Builder Layout Book for Super Duty F-Series at [www.fordbbas.com](http://www.fordbbas.com)

## TorqShift® 10R140 Transmission – Stationary Elevated Idle Control (SEIC) PTO Operating Modes (Continued)

### Models Affected

F-250/350/450/550/600 Super Duty

Diesel/Gas

Starting MY2020

### General System Behavior (Continued)

SEIC Enable/Disable Conditions				
Vehicle Conditions to Enable SEIC (all are required)	Vehicle Conditions that Disable SEIC (any one required) <sup>(1)</sup>	SEIC	*Split Shaft (Diesel Only) <sup>(3)</sup>	Mobile Mode
Parking brake applied	Parking brake disengaged	Yes	Yes	No
Foot off of service brake	Depressing service brake	Yes	Yes <sup>(2)</sup>	No
Vehicle in PARK (automatic trans.)	Vehicle taken out of PARK	Yes	Yes <sup>(2)</sup>	No
Foot off of accelerator pedal	Accelerator pedal depressed	Yes	Yes	No
Vehicle speed is 0 mph (stationary)	Vehicle speed is not 0 mph (stationary)	Yes	Yes	No
Engine at a stable base idle speed		Yes	Yes	No
Transmission Oil Temp above 20°F	Transmission Oil Temperature (TOT) Limit exceeds 240°F on Diesel and 250°F on Gas	Yes <sup>(1)</sup>	Yes <sup>(1)</sup>	Yes
Eng Coolant Temp above 20°F (6.7L Diesel)	Engine Coolant Temperature (ECT) Limit	No	No	Yes
Eng Coolant Temp above 40°F (6.2L or 7.3L Gas)	Engine Coolant Temperature (ECT) Limit	Yes <sup>(1)</sup>	Yes <sup>(1)</sup>	No
	Catalyst Temperature Limit	Yes <sup>(1)</sup>	Yes <sup>(1)</sup>	Yes
<sup>(1)</sup> A "Change-of-State" at the "PTO-REQ1" input (for Stationary Elevated Idle Control non-Split Shaft), or for both "PTO REQ1 and PTO REQ2" inputs (for Stationary Elevated Idle Control *Split Shaft) is required to re-invoke Stationary Elevated Idle Control. When a disable is seen by the PCM, the Stationary Elevated Idle Control function is de-activated, the "PTO RELAY" output circuit changes from a "ground-source" to "open circuit" and engine speed returns to base idle. To reactivate Stationary Elevated Idle Control, the operator must open the PTO Switch to the "PTO REQ1" and "PTO REQ2" inputs, then close the PTO Switch again to the "PTO REQ1" or "PTO REQ1 and PTO REQ2" inputs.				
<sup>(2)</sup> See *Split Shaft Mode description under Operating Modes.				
<sup>(3)</sup> Brake pedal must remain depressed for a minimum of <b>3 seconds</b> after moving gear shifter into DRIVE position in order to enable Split Shaft Mode.				
*We presently do not offer a Split Shaft option for this platform. Please reference Ford's Body Builder website for additional Split Shaft information.				

Please reference the most current edition of Ford's Body Builder Layout Book for Super Duty F-Series at [www.fordbbas.com](http://www.fordbbas.com)

**Transmission Overview****TorqShift® 10R140 Transmission – Stationary Elevated Idle Control (SEIC)  
PTO Operating Modes (Continued)****Models Affected**

F-250/350/450/550/600 Super Duty  
Diesel/Gas  
Starting MY2020

**General System Behavior (Continued)****Stationary Elevated Idle Control (SEIC)**

- Operates with transmission in “Park” at elevated engine speeds. Intended to be commanded ONLY by applying battery voltage to certain customer-access blunt-cut wire circuits, and adding a target-speed resistor, and is only available when the vehicle road speed CAN signal is zero.
- Includes a PTO\_RELAY circuit which changes from open circuit to ground when enablers are met, that may be used to turn on an indicator lamp, while providing battery power to an aftermarket PTO clutch or solenoid.
- Engine speed ramp-rates are configurable for all powertrains by means of an IOS tool
  - Default ramp-rate for all powertrains is 200 RPM/second
  - Configurable ramp rates are as follows:
    - Diesel:** 100 – 800 RPM/sec (in 100 RPM/sec increments)
    - Gas:** 100 – 1000 RPM/sec (in 100 RPM/sec increments)

**NOTE:** Chelsea PTO output speed should not exceed 2500 RPM. The PTO output speed is 144% of engine speed. **DO NOT** exceed 1,736 engine RPMs with Chelsea PTO installed without Chelsea engineering approval.

**\*Split Shaft Mode (Diesel Only)**

To install Split Shaft mode, wire according to the instructions provided in **Bulletin Q-256** on Ford's BBAS website. Select elevated idle speed by installing a resistor (which provides voltage to PTO RPM input) as indicated in the wiring diagram. Split Shaft mode requires that supply voltage (nominal 12VDC) be applied to both the **PTO 1** and **PTO 2** circuits.

**\*Split Shaft Engagement Procedure**

1. Ensure the following: engine is running and the engine coolant temp is above 20°F.
2. Apply park brake.
3. Disconnect vehicle drivetrain (transmission in NEUTRAL, 4x4 DISENGAGED) and engage PTO load.
4. With foot off both the service brake and accelerator pedals, turn Split Shaft PTO on.
5. While pressing the service brake, shift transmission into drive and continue holding brake for a minimum of 3 more seconds.
6. The system will shift the transmission into 7th gear, lock the converter and then ramp up to the target idle speed in a controlled manner. Release the service brake†.

†If vehicle unexpectedly lurches or moves upon releasing service brake, immediately depress brake pedal and shift transmission into PARK or NEUTRAL to secure vehicle. Contact Upfitter immediately.

\*We presently do not offer a Split Shaft option for this platform. Please reference Ford's Body Builder website for additional Split Shaft information.

**Please reference the most current edition of Ford's Body Builder Layout Book for Super Duty F-Series at [www.fordbbas.com](http://www.fordbbas.com)**

## TorqShift® 10R140 Transmission – Stationary Elevated Idle Control (SEIC) PTO Operating Modes (Continued)

### Models Affected

F-250/350/450/550/600 Super Duty  
Diesel/Gas  
Starting MY2020

### General System Behavior (Continued)

#### Battery Charge Protect (BCP)

Available on vehicles equipped with the TorqShift® 10R140 (10-speed) transmission. When 12VDC is applied to the BCP SW circuit, the engine speed goes immediately to 600. From this state, the PCM uses battery voltage, ambient air temperature, and engine oil temperature information to raise engine speed higher to maintain battery charge. Maximum engine speed in BCP mode is 1200 RPM. Loss of an operating condition after BCP is engaged will require the BCP switch to be cycled before BCP will re-engage.

- BCP cannot be active when SEIC or PTO modes are active
- A Resistor must be installed between DIESEL PTO REF (GAS PTO-VREF for 7.3L) and PTO-RPM for both Diesel and Gas engines

#### Mobile Mode

Operates in all gears and all vehicle speeds. The engine idle speed is elevated to 750 RPM when the Mobile Mode is initiated. Engine RPM is controlled by the driver through the throttle pedal but peak engine speed is not limited beyond normal operating ranges. There is no built-in provision to limit engine speed to a pre-set RPM. To prevent over-speed damage to attached pumps and equipment, an additional aftermarket RPM-limiter will be required.

Engine Speed Limiting (ESL feature) will be available on all 3 powertrains: ESL feature controls the engine speed in Mobile Mode below a selectable maximum threshold. Maximum RPM is determined by the resistor installed between the PTO\_REF and PTO-RPM circuits. See Ford BBLB ([fordbbas.com](http://fordbbas.com)) for RPM/resistor values.

- Transmission behavior changes in Mobile Mode due to upshifting performance. It is possible for a user to reach maximum RPM output in a lower gear while the transmission is unable to accelerate or upshift to the next gear.
- If this action is not desired, the operator can:
  - a. Ease up on the accelerator pedal and receive an upshift
  - b. Put the transmission in manual mode and select the gears manually
- Selected target RPM has a margin of +/- 15% based on transient conditions (for example, descending a grade)
- Mobile PTO may overshoot selected the RPM by 100-200 RPM for drivability

## TorqShift® 10R140 Transmission – Stationary Elevated Idle Control (SEIC) PTO Operating Modes (Continued)

### Models Affected

F-250/350/450/550/600 Super Duty

Diesel/Gas

Starting MY2020

### General System Behavior (Continued)

#### Mobile Mode (Continued)

**NOTE:** Parker Chelsea Electronic Overspeed Control (EOC) should be optioned with the PTO to prevent over speed damage to attached pumps and equipment.

**NOTE:** If the PTO feature is used for extended periods of time without vehicle movement it is recommended to switch to Stationary Mode.

**NOTE:** In Mobile Mode, there is no engine speed limiter unless the Engine Speed Limiter (ESL) feature is enabled via the resistor chart provided in Ford BBLB.

**NOTE:** While in Mobile Mode, when using a Chelsea PTO harness, the factory ESL function will limit the engine's maximum RPM based on potentiometer setting (clockwise to decrease, counterclockwise to increase).

**NOTE:** Without application approval from Chelsea Engineering, maximum PTO output speed is 2500 RPM (or an engine RPM of 1736).

**Installation Instructions**

**Super Duty F-250/350/450/550/600 – MY2020+ – ALL  
In-Cab PTO Switch Installation**

**NOTE:** Before starting installation of the electrical wiring:

1. Disconnect the battery cables from the battery and secure to prevent accidental contact.
2. Locate a position in the cab for mounting the PTO switch and mounting bracket. The shaded area in (Fig. 3) shows the Occupant Protection Zone of the deployed air bags that are available in these vehicles.

**WARNING:** To avoid personal injury or equipment damage: **DO NOT** install any item from a Chelsea Power Take-Off (i.e.: PTO switch or mounting bracket) in the Occupant Protection Zone.

**CAUTION:** Before drilling any holes, make sure there is adequate clearance on both sides.

For electrical installation see installation sketch on [page 26](#) for non-EOC and [page 27](#) for EOC.

3. Locate the Ford wiring to be connected to the Chelsea PTO harness.
  - a. MY2020+ blunt cut wires located at passenger side kick panel.
    - i) MY2020-2022 rectangular plug (Fig. 5).
    - ii) MY2023+ dome plug (Fig. 6).
4. After determining the location of the PTO switch, run wiring assembly over to the area of the blunt cut wires. You are now ready to attach the wires from the Chelsea wiring harness to the Ford wires (Fig. 4).
5. Connect the Chelsea wiring harness to the Ford blunt cut wires per the wiring charts on [pages 26-33](#). Butt connectors are provided on the Chelsea wiring harness.

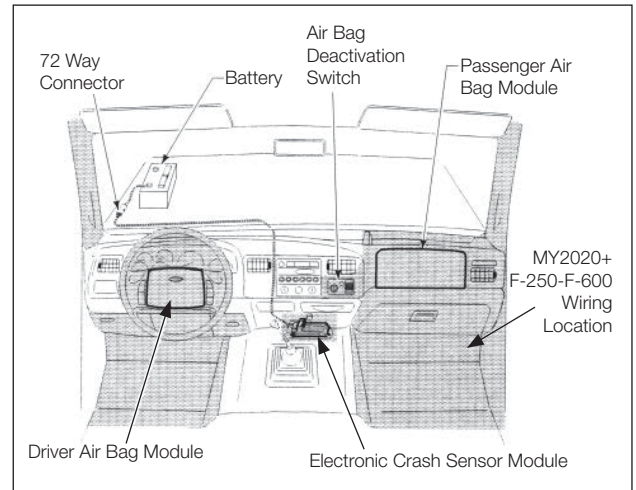

Figure 3



Figure 4

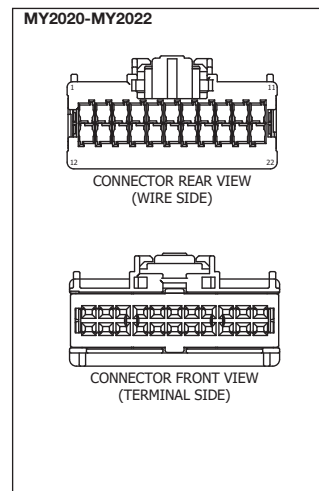

Figure 5

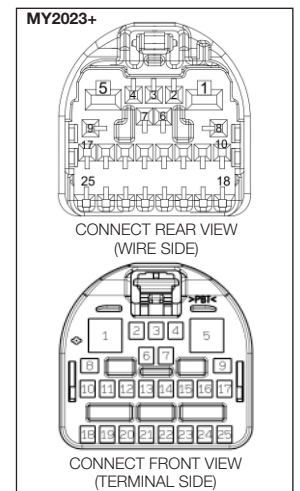

Figure 6

**WARNING:** Ensure all fasteners and fittings are torqued according to their manufacturer's specification.

**WARNING:** This symbol warns of possible personal injury.

## Super Duty F-250/350/450/550/600 – MY2020+ – ALL In-Cab PTO Switch Installation (Continued)

### Splice/Repair

When necessary to splice wire for repair or circuit length revisions, the following guide should be followed:

- Wire ends should be stripped making sure that individual conductor strands are not damaged.
- When soldering, make sure an adequate mechanical joint exists before applying solder. Use only rosin core solder — never acid core.
- For crimp joints, use butt-type metal barrel fasteners and a proper tool (such as Motorcraft crimp tool S-9796) specifically designated for this type of work.
- Splice joints must be adequately sealed and insulated. Adhesive-lined heat shrink tubing is highly recommended to cover soldered and bare metal barrel crimp joints (**Fig. 7**).
- The most durable splice joint will be bare metal barrel crimped, flow-soldered and covered with adhesive lined heat shrink tubing. This is recommended as the preferred splice joint.

**NOTE:** It is important to remember that a solid electrical connection is essential when installing any electrical device or option. A proper crimp is shown in (**Fig. 7**).

6. Attach the ground wire black with ring terminal (3/8") on its end to a confirmed ground location. Reference wiring charts on [pages 26-33](#) of this manual.
7. Wiring harness should be routed through fire wall using Chelsea provided grommet. Make sure wiring is clear of driveline and exhaust.

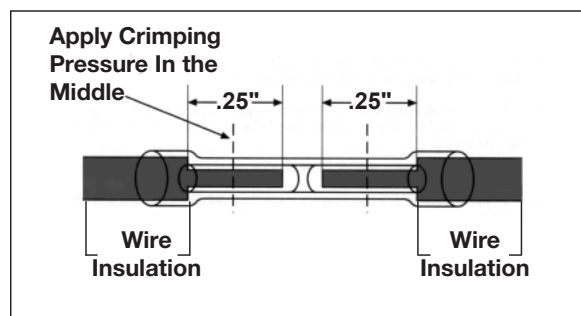

Figure 7

**CAUTION:** A 12VDC ignition voltage to the “PTO” wire is what the transmission looks for to initiate commands. Failing to do so may show up as low or oscillating hydraulic line pressure and low or no PTO torque or pump flow output. Any attempt to operate the Power Take-Off at elevated idle without these commands may result in under-capacity PTO clutch wear, resulting in rapid contamination of transmission fluid and internal transmission damage. This applies to both stationary and mobile automatic transmission PTO operations. Reference wiring charts on [pages 26-33](#).

**NOTE:** Chelsea wiring harness includes a potentiometer factory set to maximum resistance which defaults to the minimum engine RPM established by Ford. See [FordBBAS.com](#) for resistor values.

**Installation Instructions****Super Duty F-250/350/450/550/600 – MY2020+ – ALL  
PTO Installation – Overview**

1. Refer to [pages 17-25](#) of this manual for PTO installation.
2. Gas applications require thermal sleeving to protect PTO pressure switch and lube hose. Gas specific wiring harness feature high temperature heat loom.
3. Directly connected hoses must be routed away from exhaust and rotating components.
4. After wiring harness is connected to PTO solenoid valve and pressure switch, ensure harness has sufficient clearance from exhaust pipe and all rotating components.

**Super Duty F-250/350/450/550/600 – MY2020+ – ALL  
PTO Installation – Pre-work**

**CAUTION:** Always wear suitable Personal Protective Equipment (PPE) when installing the PTO. Safety glasses and gloves are recommended.

**Overview:** The 210 Series PTO has a single housing for all configurations. There is no separate geared adapter.

1. If NVH Cover is installed over PTO opening, cut away portion of the cover as described in Ford SVE Bulletin Q-300 (available at [www.fordbbas.com](http://www.fordbbas.com), see **Fig. 8**). Exercise caution when removing cover. Avoid any damage or severing of transmission, wiring, and fluid lines.

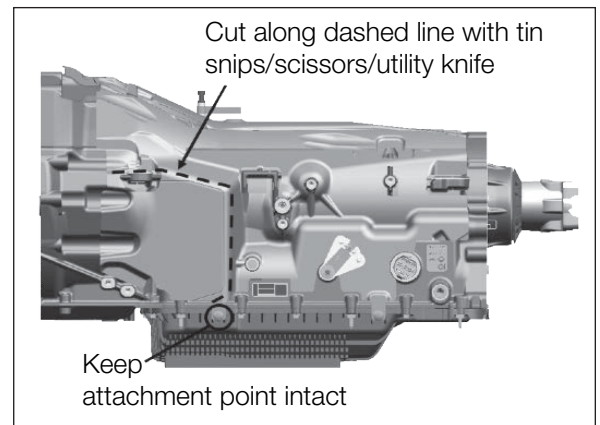

Figure 8

2. Install the PTO pressure switch onto port on the hydraulic valve cap. Torque to 10-12 lb-ft [13-16 N-m] (**Fig. 9**).

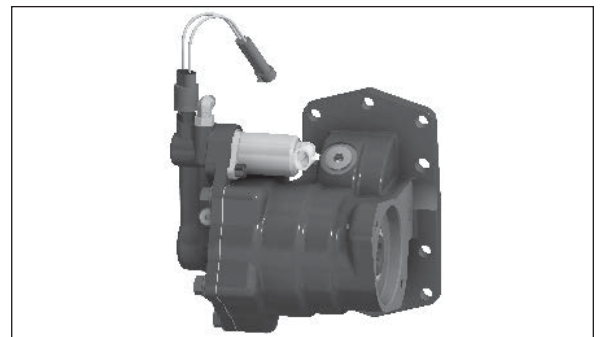

Figure 9

## Super Duty F-250/350/450/550/600 – MY2020+ – ALL (Continued) PTO Installation – Pre-work (Continued)

**CAUTION:** Thermal Sleeving is required for Gas installations.

- a. Slide on segment of thermal sleeving over pressure switch and connector.
- b. Use one of included stainless steel cable ties to secure the pressure switch end of sleeve-to-sleeve body (**Fig. 10**).
- c. Note that the sleeve is several inches longer than the switch wires. Once installed, the connector end of the sleeve should slide over the mating connector and any exposed wires to the harness shielding.



Figure 10

3. Remove the O-ring mounting seal from the PTO installation kit and align it with the groove on the PTO flange. Press firmly along the length of the seal until the seal is firmly seated in the groove. O-ring lubrication compound may assist the installation of the seal into the housing (**Fig. 11 and Fig. 12**).

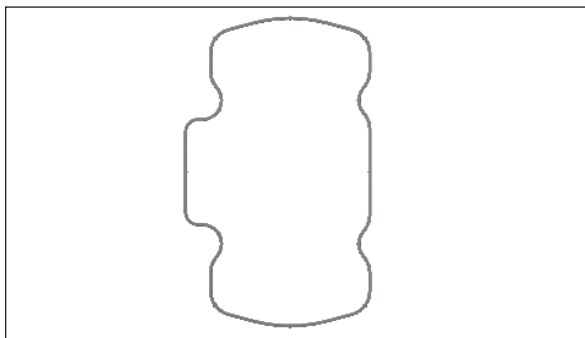

Figure 11

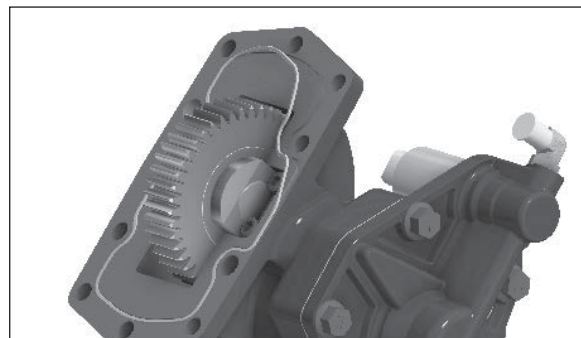

Figure 12

**NOTE:** Inspect the seal for damage before and after assembly. If there is any uncertainty about its condition, replace with a new seal (PN 28-P-397).

**NOTE:** Do not use sealing compounds because they are generally incompatible with automatic transmission fluids and may contaminate transmission valve bodies.

**NOTE:** For 4x4 applications, the 4WD auxiliary driveshaft will need to be dropped to allow for PTO installation. For most installations, the electrical bulkhead connector located near the rear of the transmission does not need to be removed.

**This transmission does not require the oil to be drained for PTO installation. However, minor drainage should be expected when covers and plugs are removed.**

**⚠ WARNING:** Oil may be hot. Use extreme caution during installation and removal of PTO to prevent accidental contact with hot fluid.

**⚠ This symbol warns of possible personal injury.**

## Super Duty F-250/350/450/550/600 – MY2020+ – ALL (Continued) PTO Installation – Pre-work (Continued)

4. Remove the transmission pressure port plug (**Fig. 13**) and follow the instructions outlined below to ensure the 90-degree Adapter Fitting (PN 380750 in **Fig. 14** and **Fig. 15**) is properly installed.

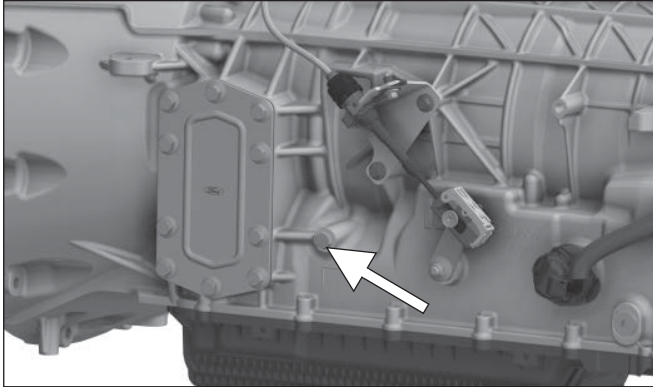

Figure 13

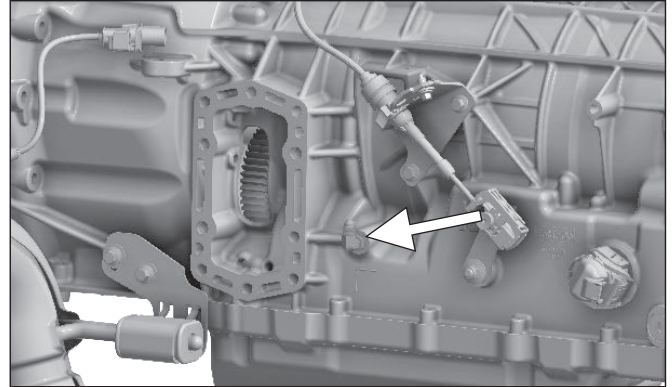

Figure 14

**IMPORTANT:** Both washers (captive and loose) and the O-ring must be present at installation. The second washer must fit around the O-ring for proper seal (**Fig. 15**).

- a. **Step 1:** Inspect components to ensure that male and female port threads and sealing surfaces are free of burrs, nicks, and scratches, or any foreign material.
- b. **Step 2:** If O-ring or seal is not pre-installed to fitting male port end, install proper size O-ring or seal, taking care not to damage it.
- c. **Step 3:** Lubricate O-ring with light coat of system fluid or a compatible lubricant to help the O-ring slide smoothly into the port and avoid damage.
- d. **Step 4:** Back off lock nut as far as possible. Make sure back-up washer is not loose and is pushed up as far as possible.
- e. **Step 5:** Screw fitting into port until the back-up washer or the retaining ring contacts face of the port. Light wrenching may be necessary. **Over tightening may damage washer.**



Figure 15

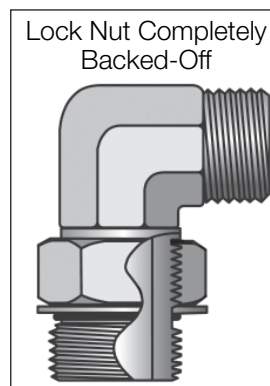

Step 4

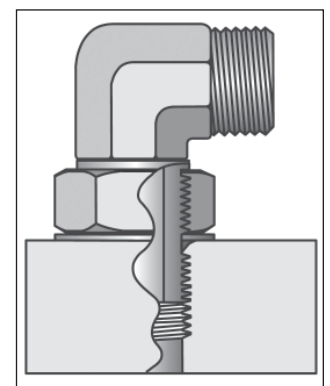

Step 5

**Super Duty F-250/350/450/550/600 – MY2020+ – ALL (Continued)**  
**PTO Installation – Pre-work (Continued)**

- f. **Step 6:** To align the tube end of the fitting to accept incoming tube or hose assembly, unscrew the fitting by the required amount, but not more than one full turn.

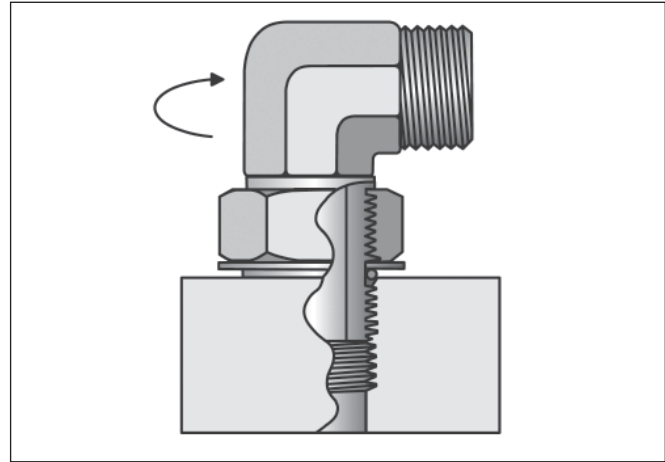

Step 6

- g. **Step 7:** Using two wrenches, hold fitting in desired position and tighten lock nut. Torque to 10-12 lb-ft [13-16 N-m].
- h. **Step 8:** Inspect to ensure that O-ring is not pinched and that washer is seated flat on face of port.

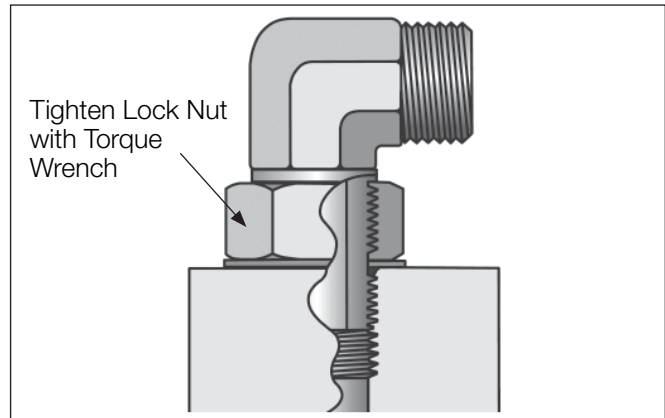

Step 7 and 8

- 5. Remove and discard the PTO aperture cover plate and gasket. Do not use this gasket when installing the PTO (**Fig. 16 and Fig. 17**).

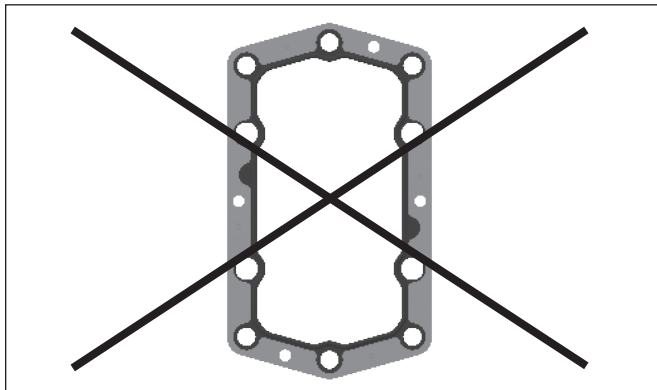

Figure 16

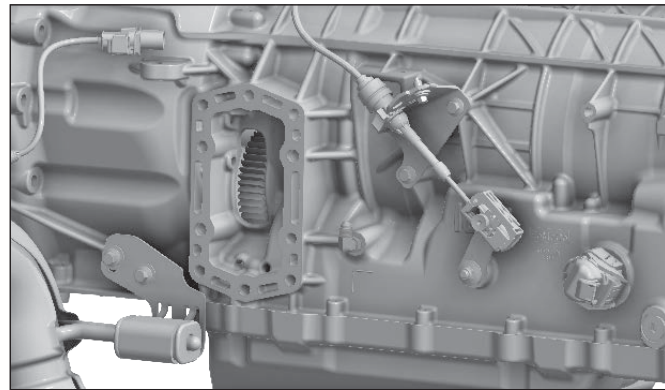

Figure 17

**Installation Instructions****Super Duty F-250/350/450/550/600 – MY2020+ – ALL (Continued)**  
**PTO Installation**

6. Eight bolts and two alignment pins and dowel bushings (**Fig. 18**) are used to attach the PTO to the transmission opening.

**NOTE:** Do not use sealing compounds because they are generally incompatible with automatic transmission fluids and could possibly contaminate valve bodies in the transmission.

7. Install the two alignment pins to the 2 O'clock and 8 O'clock mounting positions.

**CAUTION:** Over tightening the mounting hardware may damage the transmission threads.

8. Install the dowel bushings over the alignment pins so that they are seated in the transmission counterbores (**Fig. 19**).

9. Align the PTO over the alignment dowels and press firmly to seat. Ensure that the mounting seal does not fall out of the groove before it is compressed against the transmission face (**Fig. 20**).

10. Install the provided bolts to the remaining faster locations and torque to 24-28 lb-ft [32-37 N-m] in a crossing pattern (**Fig. 21**).

**NOTE:** Always torque fasteners in a crossing pattern (**Fig. 21**).

**CAUTION:** Over tightening the mounting hardware may damage the transmission threads.



Figure 18

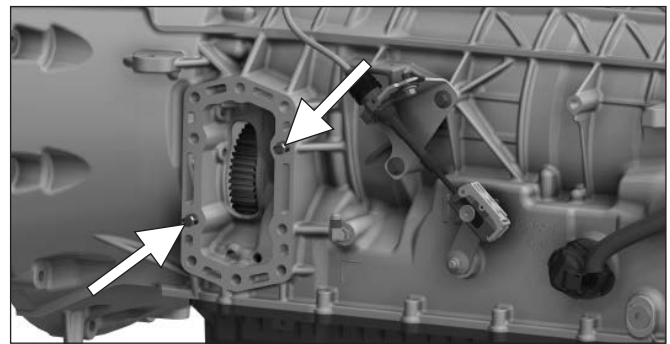

Figure 19

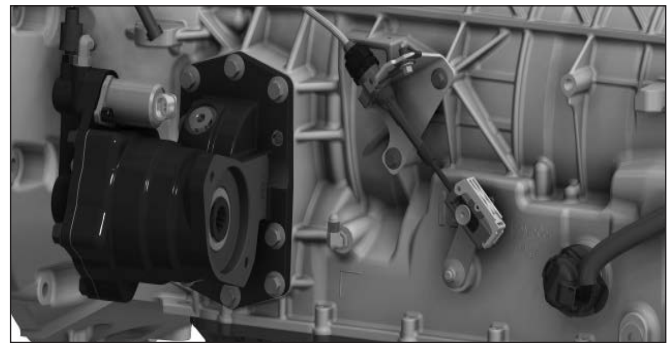

Figure 20

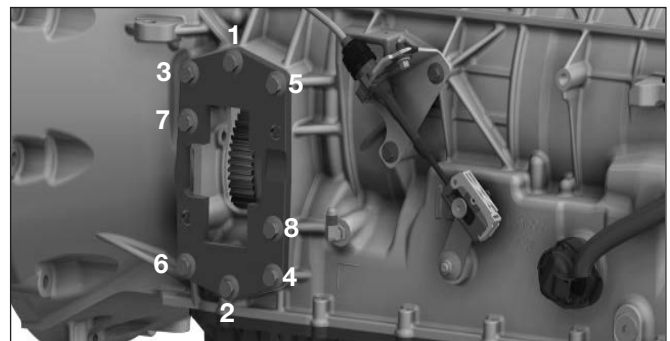

Figure 21

## Super Duty F-250/350/450/550/600 – MY2020+ – ALL (Continued) PTO Installation (Continued)

### PTO Pressure/Lube Fitting & Hose:

329784-3X Hose Assembly (1 each) (**Fig. 22**).

11. Connect hose assembly (PN 329784-3X) to the 90-degree fitting previously installed on the transmission. Chelsea recommends all hoses be routed above the PTO as shown in (**Fig. 23**). Some large pumps may require lube hose to be routed below the PTO (**Fig. 24**) due to clearance to the transmission fitting. Hold hose fitting in desired position and tighten lock nut with a wrench until solid feeling is encountered. From that point, apply one-sixth turn. Next, connect the other end of the hose to fitting on the PTO valve cap. Tighten until solid feeling is encountered. From that point, apply one-sixth turn.

**! WARNING:** Oil may be hot. Use extreme caution to assure that you do not accidentally come in contact with hot oil.

12. For Gas applications, thermal sleeving is required for lube hose assembly. Slide sleeve over lube hose. Secure sleeve with included steel cable ties to metal hose ends of the assembly (**Fig. 24**).

**! WARNING:** Installers MUST secure all wiring and hoses with maximum possible clearance from exhaust so there is no contact with exhaust while in operation.

**NOTE:** If smaller pumps (PGP511 or similar) are used on 4x4 applications, hose should be routed behind the pump and above the PTO. On gas applications, routing the hose above the pump is highly recommended if possible to maintain maximum clearance from the vehicle exhaust. The provided heat sleeve should also be installed (**Fig. 23**).

**NOTE:** If larger pumps (PGP315, P16, or similar) are used on 4x4 applications, the pump body may not allow the hose to be routed behind the pump. In these applications, the hose may be routed beneath the PTO and for gas applications the provided heat sleeve must be used to prevent damage to the hose (**Fig. 24**).

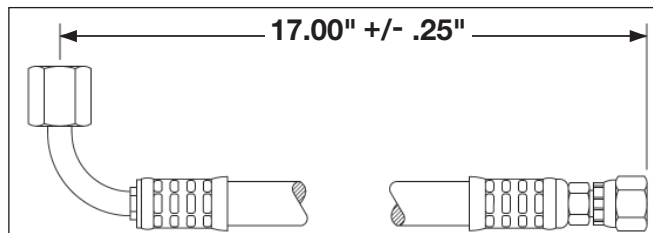

Figure 22

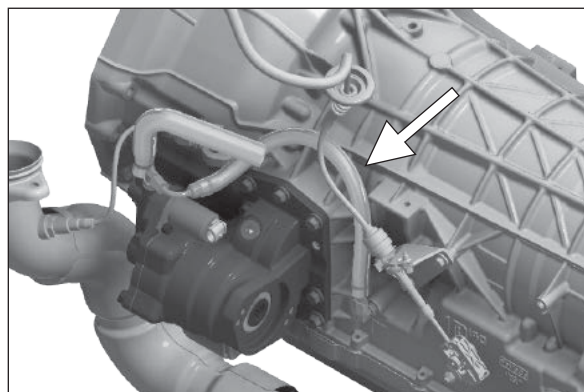

Figure 23

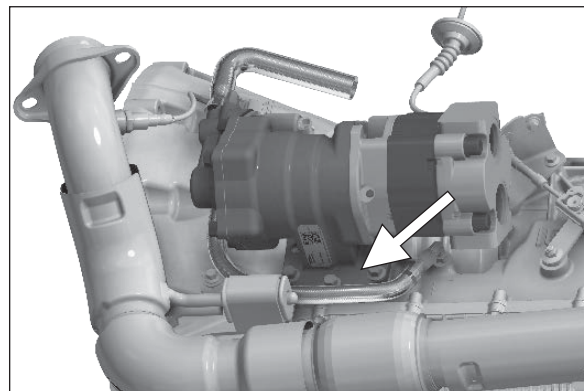

Figure 24

**! This symbol warns of possible personal injury.**

## Super Duty F-250/350/450/550/600 – MY2020+ – ALL (Continued) PTO Installation (Continued)

**NOTE:** Due to the dynamic motion and potential loading of a 4x4 vehicle using the 10R140 transmissions, there is a possible interference between the pump and the driveshaft if the pump is mounted with the bulge out towards the driveshaft. Clearance between the pump and the 4x4 driveshaft is not as large as it may seem when the vehicle is stationary or on a lift. Therefore, our engineering team stresses all 4x4 compatible pumps **MUST** be mounted with the bulge toward the transmission.

13. Connect wiring harness as shown on [pages 26-27](#).
14. Recommended pump mounting position (**Fig. 25**).
15. If installing a Chelsea Pump, torque bolt to 24 lb-ft [32 N-m].
16. Check transmission oil level per Ford guidelines.

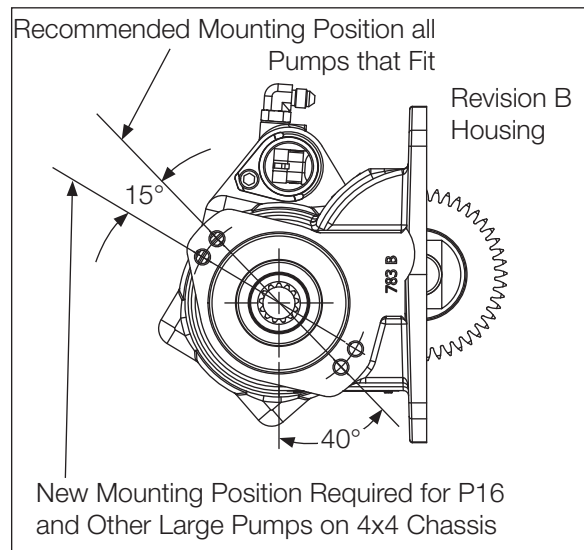

Figure 25

## Transmission/PTO Electrical Operation

1. When vehicle is on, power is supplied to switch via **12VDC IGN**
2. Switch illumination is controlled by **Light Control**. When PTO pressure switch closes (PTO is engaged), **Light Control** will be connected to ground via vehicle ground and the light will illuminate independent of on/off status of switch. A high-quality ground connection is important to prevent electrical errors that may be difficult to diagnose.
3. When switch is toggled on, power is supplied via **Power Out** to **PTO-REQ**. The relay will not actuate because the Ford power control module (PCM) has blocked the **PTO-RELAY** connection from receiving power until it is ready.
4. When the PCM gets voltage at **PTO-REQ**, initiates SEIC mode. This may include adjustment of the idle speed, cooling parameters, and transmission line pressure, depending on the selected mode. Note that the mode is selected by wiring to either Ford circuit **PTO 1** or **PTO 2**. The vehicle may fail to enter PTO mode if any of several safeguards not met. See Ford Body Builder's Guide for detailed information on these limitations.
5. If all checks are successful, transmission will enter PTO mode and increase hydraulic line pressure to 200 PSI for PTO clutch operation. Engine speed will also ramp to minimum required by operational mode. If PTO mode cannot be enabled, no changes will occur.
6. For SEIC operation, the engine speed will ramp to the level determined by the potentiometer circuit. The PCM outputs a reference voltage to **PTO-VREF** and provides a ground signal at **PTO-RTN**. The potentiometer is used as a voltage divider; adjusting it clockwise reduces the voltage measured at **PTO-RPM** (and vice versa). The voltage measured by the PCM at **PTO-RPM** is used to set the SEIC speed relative to the minimum and maximum speeds allowed by Ford. Consult the Ford Body Builder's Guide for correlations of voltage and SEIC RPM.
7. The PCM connects the **PTO-RELAY** connection to ground, which allows power to flow through the relay control circuit to close the relay. Once closed, the relay sends power to the PTO solenoid valve to actuate and engage the PTO.
8. PTO will continue to operate until any safeguard is violated and PTO mode is forcibly disabled by the PCM, or the PTO switch is toggled to cut power to the PTO system. If PTO mode is forcibly disabled, the PTO switch will need to be toggled after the error is resolved to re-enter PTO mode.

**Wiring Installation (Shift Option B)  
 Super Duty F-250/350/450/550/600 – MY2020+  
 w/o Electronic Overspeed Control (EOC)  
 210 Series**

**(SK-658)**

Integration Kit: 330007-2X (Included in 330008X)  
 Harness: 329616X (Diesel Only)  
 Harness: 75-P-39 (Gas Only)

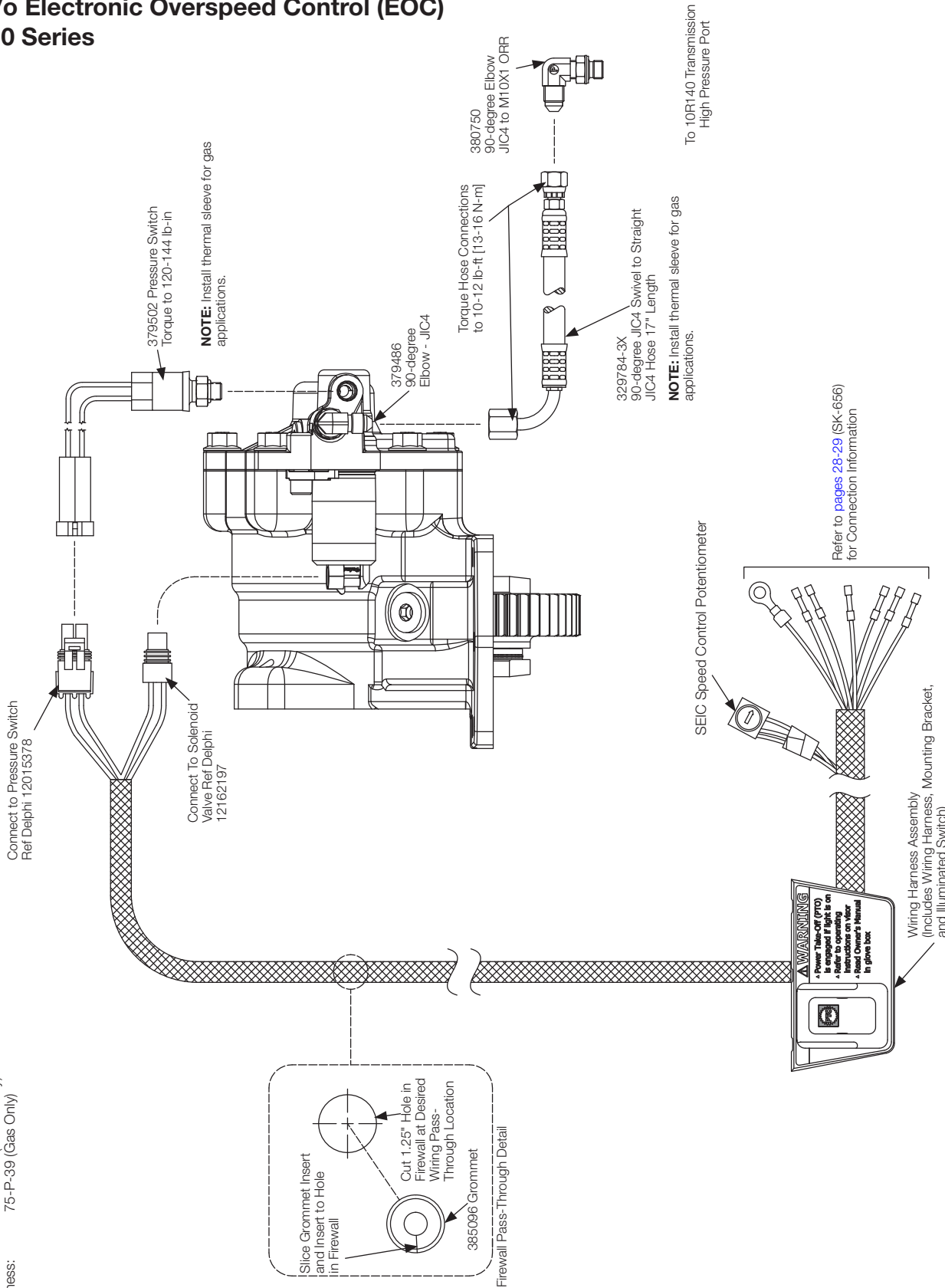

**NOTE:**  
 Chelsea Installation Sketch SK-656 on pages 28-29.  
 Reference Ford Body Builder Advisory Service (BBAS)

Wiring Installation (Shift Option K)  
Super Duty F-250/350/450/550/600 – MY2020+  
w/ Electronic Overspeed Control (EOC)  
210 Series

(SK-660)

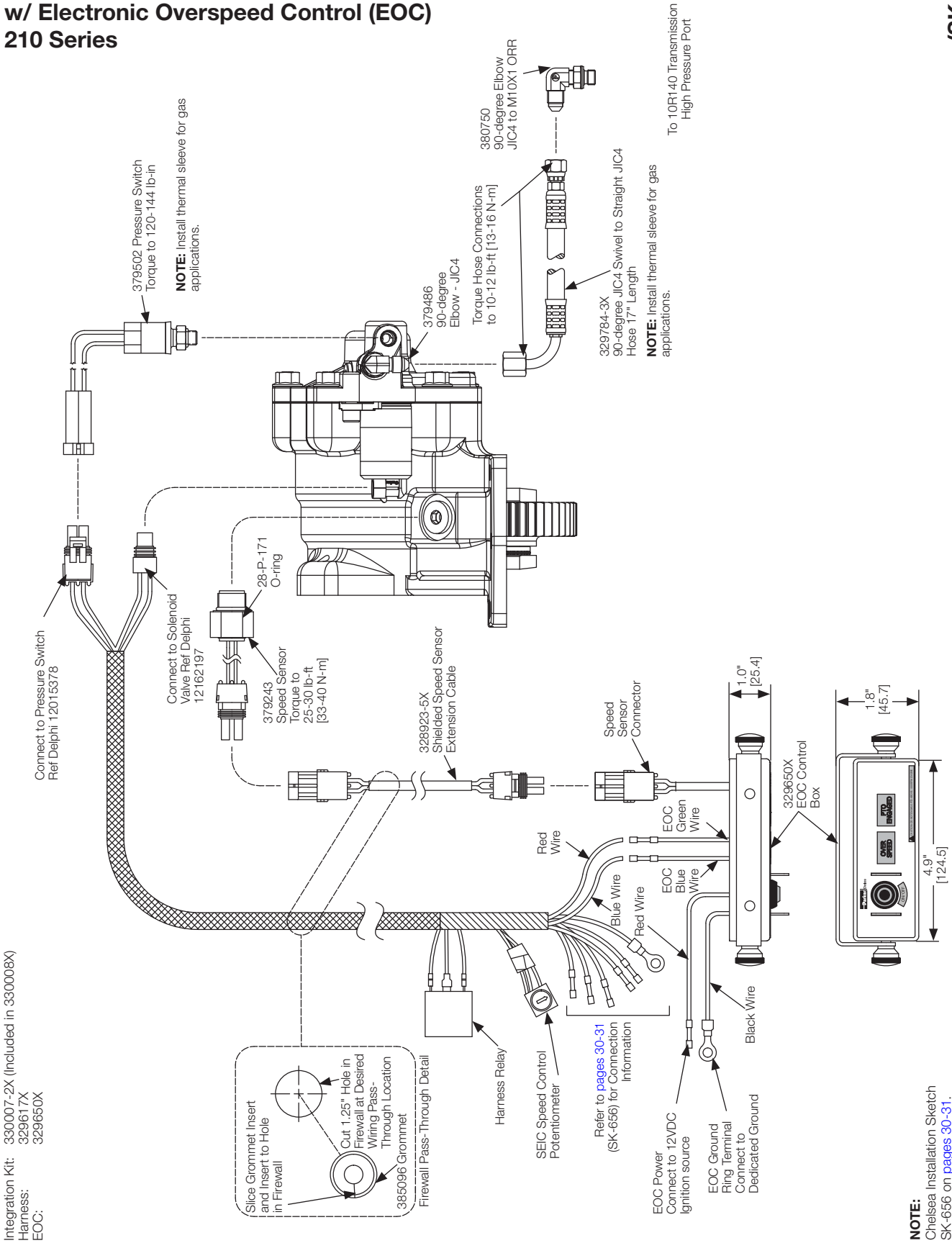

**Wiring Installation PTO to Ford  
 Super Duty F-250/350/450/550/600 – MY2020+  
 w/o Electronic Overspeed Control (EOC)  
 210 Series**

**(SK-656 Rev B)**

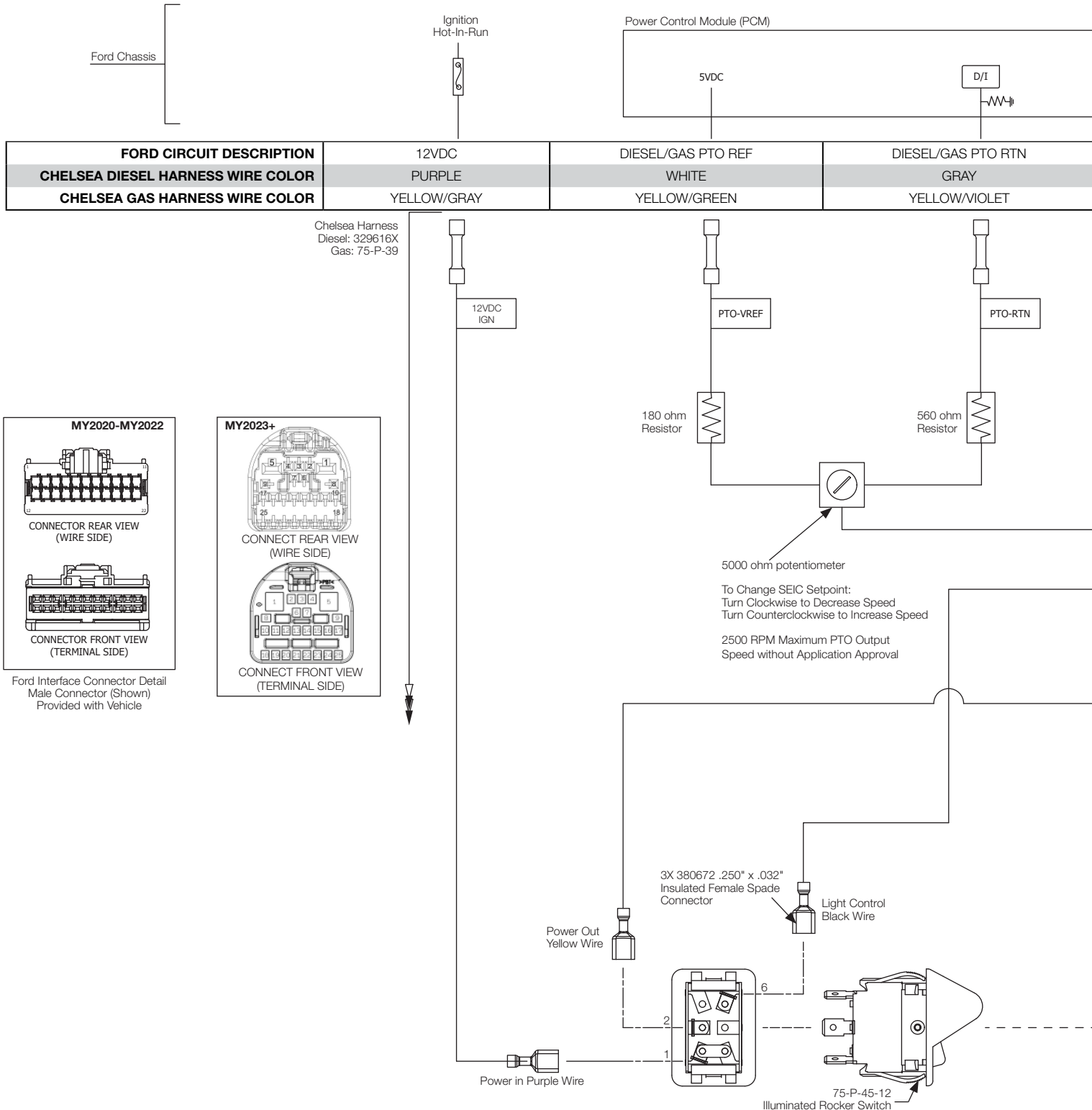

**NOTE:** Reference Chart on [pages 32-33](#) for appropriate wiring.

Please reference the most current edition of Ford's Body Builder Layout Book for Super Duty F-Series at [www.fordbbas.com](http://www.fordbbas.com)

Installation Sketches

Wiring Installation PTO to Ford (Continued)  
Super Duty F-250/350/450/550/600 – MY2020+  
w/o Electronic Overspeed Control (EOC)  
210 Series

(SK-656 Rev B)

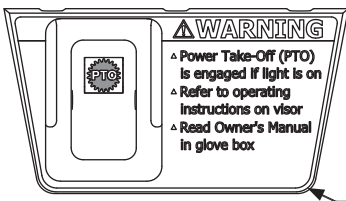
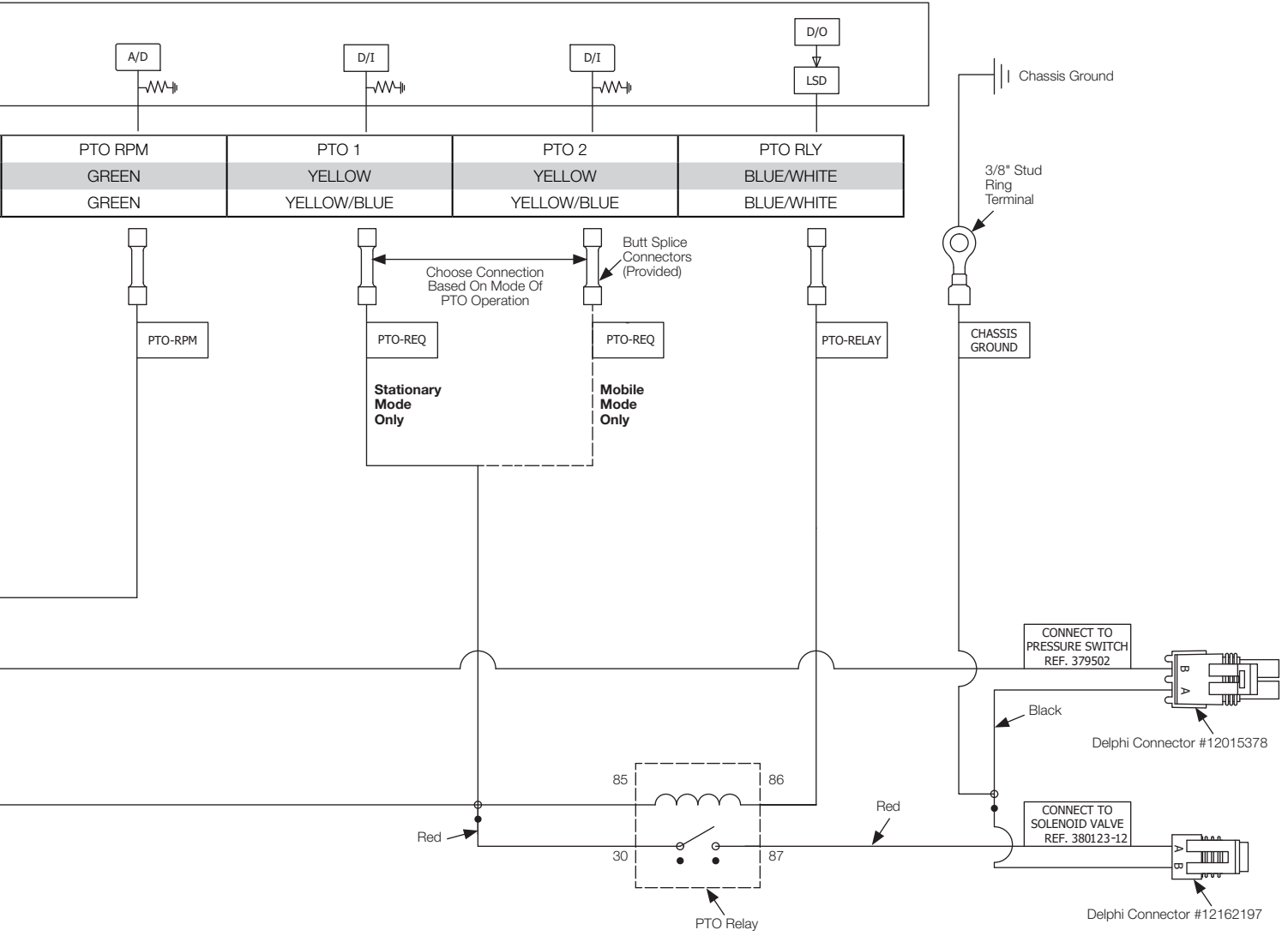

- NOTES:**
- 1) All Chelsea Harness Wire is 18 AWG.
  - 2) Potentiometer is Preset to Furthest Clockwise Position (Minimum Speed).
  - 3) Relay is Secured to Reverse of Bracket (Non EOC Only).
  - 4) Refer to Ford SVE Bulletin Q-256.

Please reference the most current edition of Ford's Body Builder Layout Book for Super Duty F-Series at [www.fordbbas.com](http://www.fordbbas.com)

**(SK-656 Rev B)**

**Wiring Installation PTO to Ford  
 Super Duty F-250/350/450/550/600 – MY2020+  
 w/ Electronic Overspeed Control (EOC)  
 210 Series**

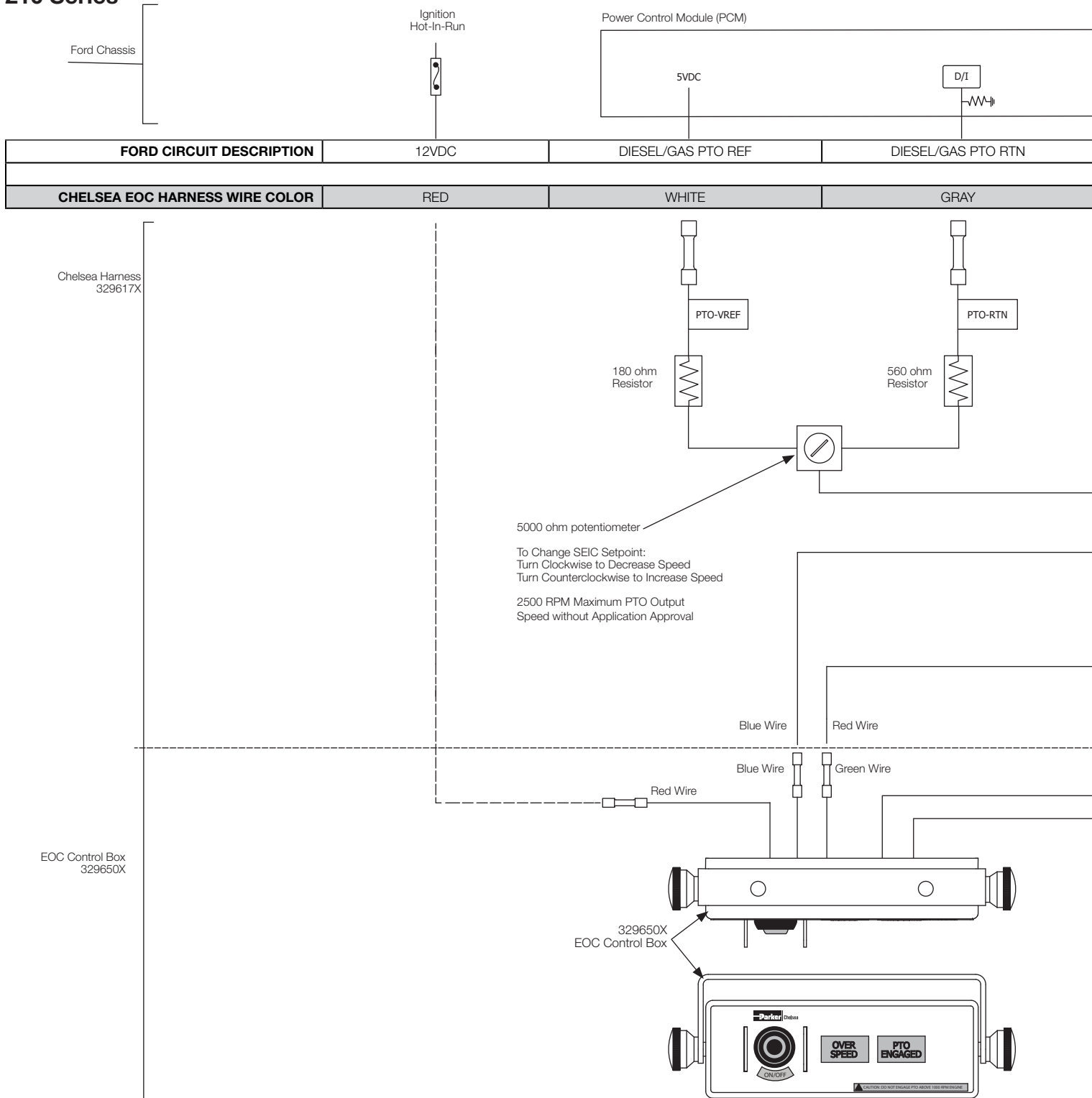

**NOTE:** Reference Chart on [pages 32-33](#) for appropriate wiring.

Please reference the most current edition of Ford's Body Builder Layout Book for Super Duty F-Series at [www.fordbbas.com](http://www.fordbbas.com)

**Wiring Installation PTO to Ford (Continued)**  
**Super Duty F-250/350/450/550/600 – MY2020+**  
**w/ Electronic Overspeed Control (EOC)**  
**210 Series**

(SK-656 Rev B)

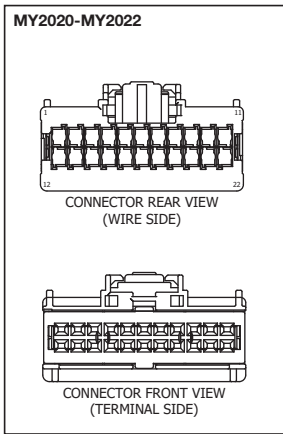
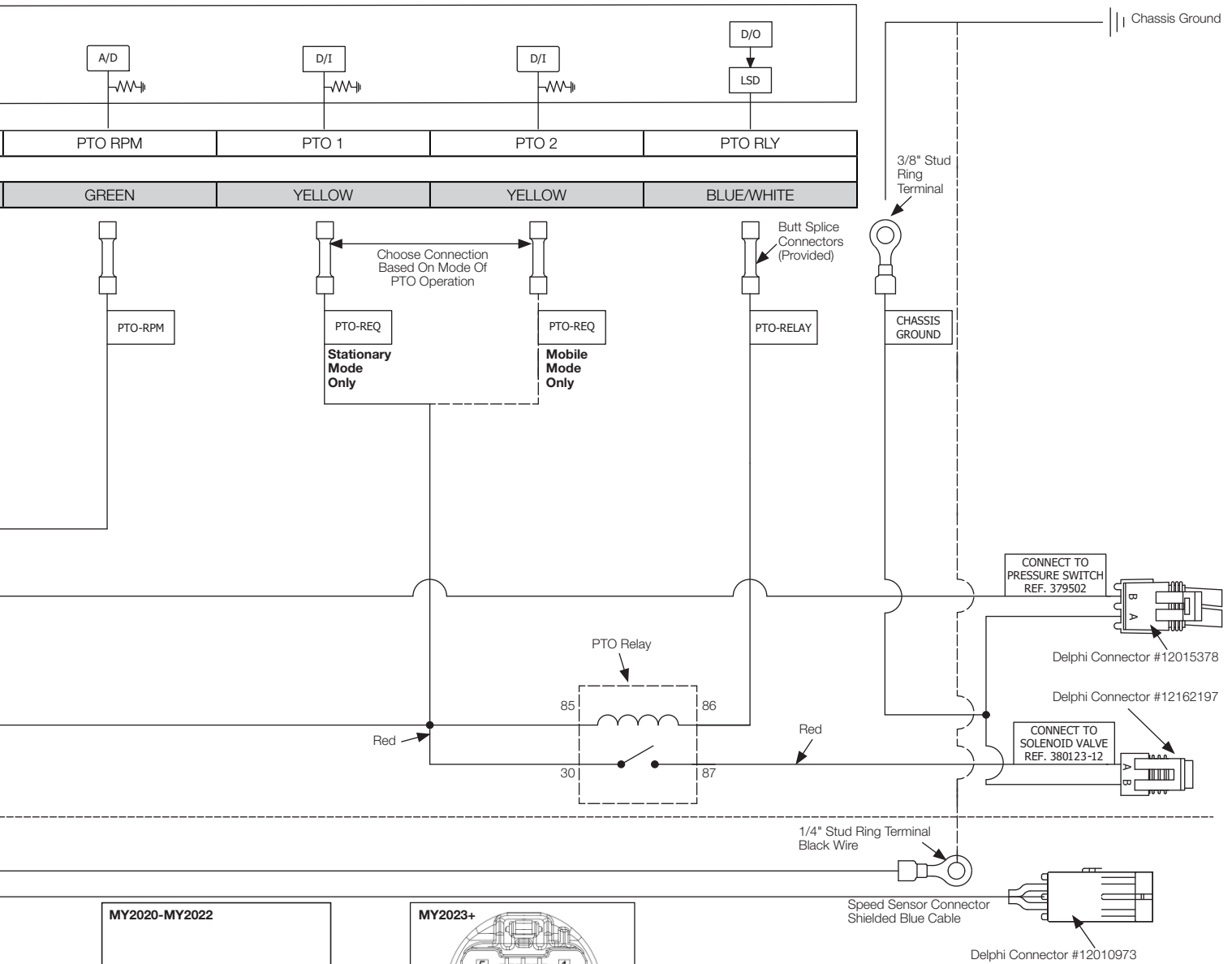

Ford Interface Connector Detail Male Connector (Shown) Provided with Vehicle

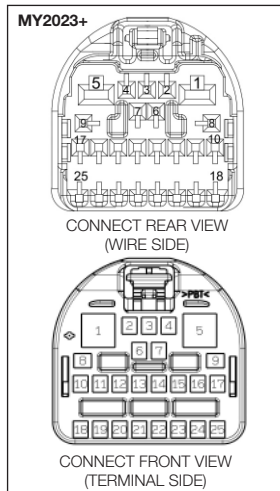

**NOTES:**

- 1) All Chelsea Harness Wire is 18 AWG.
- 2) Potentiometer is Preset to Furthest Clockwise Position (Minimum Speed).
- 3) Relay is Secured to Reverse of Bracket (Non EOC Only).
- 4) Refer to Ford SVE Bulletin Q-256.

Please reference the most current edition of Ford's Body Builder Layout Book for Super Duty F-Series at [www.fordbbas.com](http://www.fordbbas.com)

**Wiring Installation Chart PTO to Ford  
 Super Duty F-250/350/450/550/600 – MY2020+  
 w/ and w/o Electronic Overspeed Control (EOC)  
 210 Series**

SUPER DUTY F-250/350/450/550/600		IGNITION HOT-IN-RUN	5VDC PTO REF	PTO-RTN
FORD CIRCUIT NUMBER		CBP22	LE424 (GAS) LE434 (DIESEL)	RE407 (GAS) RE327 (DIESEL)
2020	6.2L and 7.3L GASOLINE	GREEN/ORANGE	YELLOW/GREEN	YELLOW/VIOLET
	6.2L and 7.3L GASOLINE - MOBILE MODE			
	6.7L DIESEL		WHITE/BROWN	GRAY/VIOLET
	6.7L DIESEL - MOBILE MODE			
FORD CIRCUIT NUMBER		CBP22	LE424 (GAS) LE434 (DIESEL)	RE407 (GAS) RE327 (DIESEL)
2021	6.2L and 7.3L GASOLINE	GREEN/ORANGE	YELLOW/GREEN	YELLOW/VIOLET
	6.2L and 7.3L GASOLINE - MOBILE MODE			
	6.7L DIESEL		WHITE/BROWN	GRAY/VIOLET
	6.7L DIESEL - MOBILE MODE			
FORD CIRCUIT NUMBER		CBP22	LE424 (GAS) LE434 (DIESEL)	RE407 (GAS) RE327 (DIESEL)
2022	6.2L and 7.3L GASOLINE	GREEN/ORANGE	YELLOW/GREEN	YELLOW/VIOLET
	6.2L and 7.3L GASOLINE - MOBILE MODE			
	6.7L DIESEL		WHITE/BROWN	GRAY/VIOLET
	6.7L DIESEL - MOBILE MODE			
FORD CIRCUIT NUMBER		CBP22	LE424 (GAS) LE434 (DIESEL)	RE407 (GAS) RE327 (DIESEL)
2023	7.3L GASOLINE	BROWN/BLUE	YELLOW/GREEN	YELLOW/VIOLET
	7.3L GASOLINE - MOBILE MODE			
	6.7L DIESEL		WHITE/BROWN	GRAY/VIOLET
	6.7L DIESEL - MOBILE MODE			

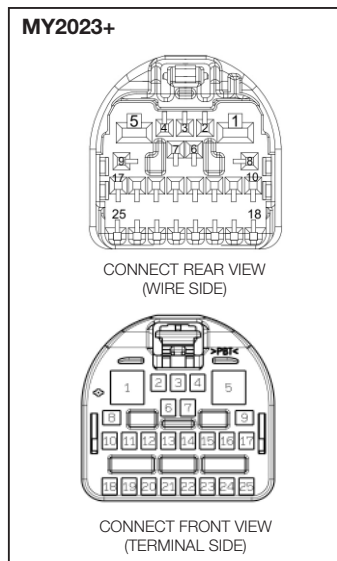
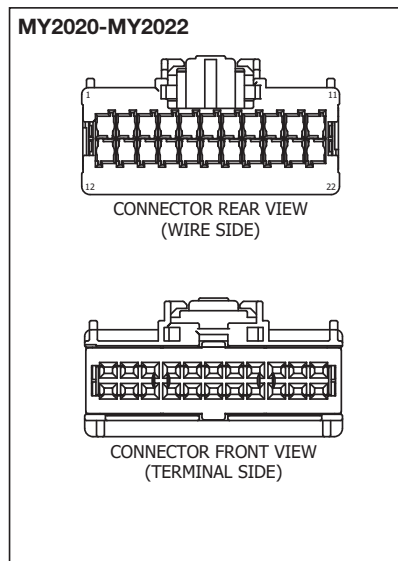

**Wiring Installation Chart PTO to Ford (Continued)**  
**Super Duty F-250/350/450/550/600 – MY2020+**  
**w/ and w/o Electronic Overspeed Control (EOC)**  
**210 Series**

PTO-RPM	PTO1 (STATIONARY)	PTO2 (MOBILE)	PTO RELAY	SUPER DUTY F-250/350/450/550/600	
CE914	CE912	CE933	CE326	FORD CIRCUIT NUMBER	
GREEN	YELLOW/GREEN		BLUE/WHITE	2020	6.2L and 7.3L GASOLINE
		BLUE/ORANGE			6.2L and 7.3L GASOLINE - MOBILE MODE
	YELLOW/GREEN				6.7L DIESEL
		BLUE/ORANGE			6.7L DIESEL - MOBILE MODE
CE914	CE912	CE933	CE326	FORD CIRCUIT NUMBER	
GREEN	YELLOW/GREEN		BLUE/WHITE	2021	6.2L and 7.3L GASOLINE
		BLUE/ORANGE			6.2L and 7.3L GASOLINE - MOBILE MODE
	YELLOW/GREEN				6.7L DIESEL
		BLUE/ORANGE			6.7L DIESEL - MOBILE MODE
CE914	CE912	CE933	CE326	FORD CIRCUIT NUMBER	
GREEN	YELLOW/GREEN		BLUE/WHITE	2022	6.2L and 7.3L GASOLINE
		BLUE/ORANGE			6.2L and 7.3L GASOLINE - MOBILE MODE
	YELLOW/GREEN				6.7L DIESEL
		BLUE/ORANGE			6.7L DIESEL - MOBILE MODE
CE914	CE912	CE933	CE326	FORD CIRCUIT NUMBER	
GREEN	YELLOW/GREEN		BLUE/WHITE	2023	7.3L GASOLINE
GREEN/WHITE		BLUE/ORANGE			7.3L GASOLINE - MOBILE MODE
GREEN	YELLOW/GREEN				6.7L DIESEL
GREEN/WHITE		BLUE/ORANGE			6.7L DIESEL - MOBILE MODE



# 810 Series

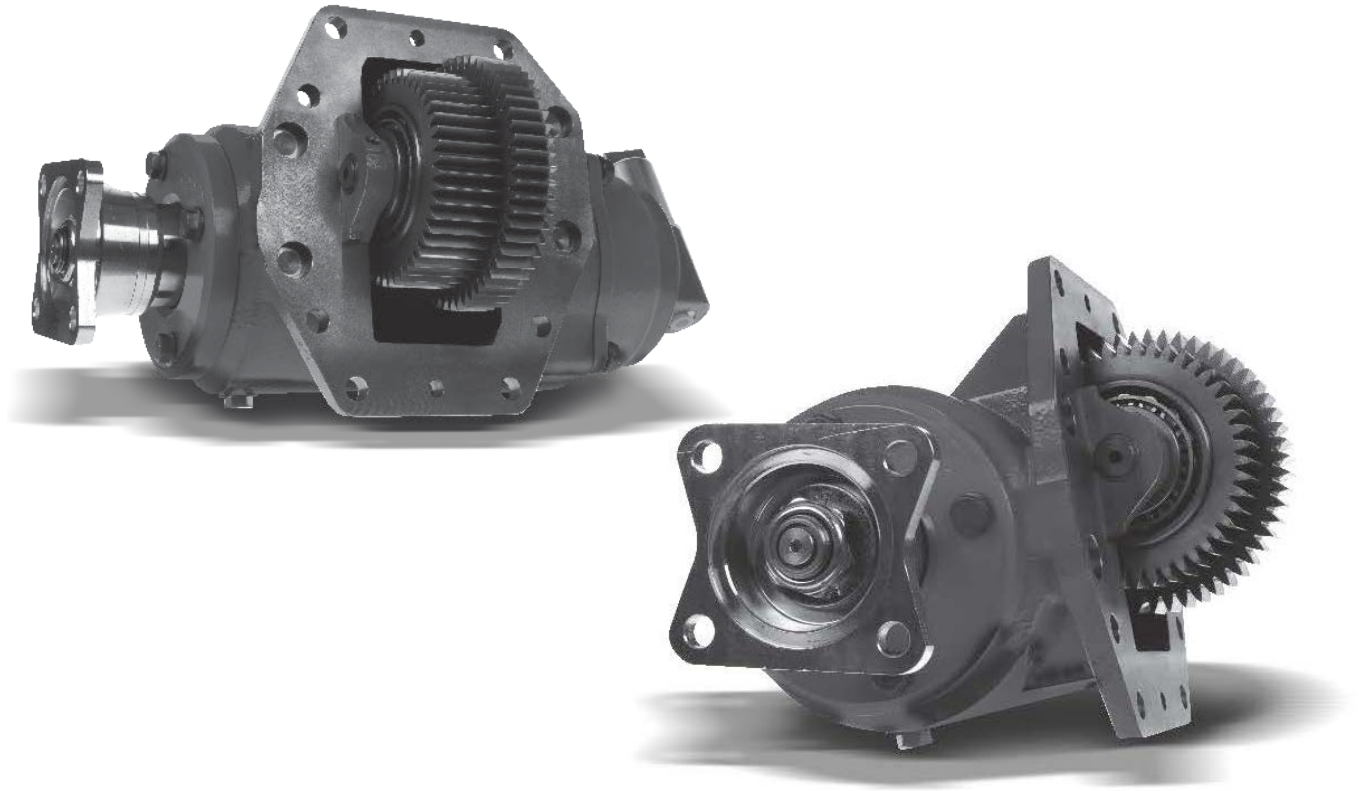

## **FORD TorqShift® HD 10R140 Transmission**

**Medium Duty F-650/F-750  
6.7L Diesel  
MY2024+**

## TorqShift® HD 10R140 Transmission – Stationary Elevated Idle Control (SEIC) PTO Operating Modes

### Models Affected

F-650/F-750 Medium Duty

6.7L Diesel

MY2024+

### General System Behavior

- To guarantee full advertised torque capability at the automatic transmission PTO gear and through the aftermarket PTO clutch, the hydraulic line pressure serving the aftermarket PTO clutch must be elevated. Applying battery voltage to the PTO circuit is the signal to the transmission to enter SEIC strategy. This applies to both stationary and mobile PTO operations.
- If an SEIC disabler occurs:
  - ALL engines will require a “change-of-state”, meaning the operator is required to turn off voltage to the “PTO-Request” circuit, and back on again to re-invoke SEIC and PTO operation.
- Battery Charge Protection (BCP):
  - When it is switched on the engine speed goes immediately to 600 RPM and stays there even if the battery is fully charged. From this state it uses system voltage, as well as ambient air temperature, and engine oil temperature information to raise engine speed higher to maintain a certain battery charge. Maximum engine speed in BCP mode is 1200 RPM.
- Auto Entry:
  - The BCP and Live-Drive operation modes allow PTO to engage automatically once the engine is started provided the input switch is left in the on position prior to starting the engine. However, loss of an operating condition after PTO is initially engaged will require the switch to be cycled before PTO will re-engage.
- The Transmission Control Module (TCM) will turn off the PTO system when Transmission Oil Temperature (TOT) reaches 240°F on Diesel applications.
- If the Transmission Oil Temperature (TOT) sensor reaches 240°F, the PTO system may disengage, preventing torque from being delivered to the aftermarket transmission PTO.
- SEIC/PTO strategy function in the PCM is not affected by the loss of vehicle battery electrical power.
- SEIC Ramp Rate:
  - When first applying battery voltage to the PTO circuit the PCM directs the engine to go to the initial target that it sees at the RPM circuit at 200 RPM/second.
  - The correlation will be better for diesel engines since the diesel engine SEIC system offers buffered PCM voltage and ground circuits to complete the resistor circuits for engine speed.
  - If there is a high electrical demand on the chassis battery, such as from aftermarket inverters or generators, etc., the actual elevated idle engine speed may vary with that demand for any given resistance in the SEIC circuit.
- Configurable ramp rates are as follows:
  - The SEIC system offers buffered PCM voltage and ground circuits to complete the resistor circuits for engine speed.
  - The SEIC system offers buffered PCM voltage and ground circuits to complete the resistor circuits for engine speed.

Reference Ford Body Builder website for most up-to-date information at <https://www.fordbbas.com/>

---

## TorqShift® HD 10R140 Transmission – Stationary Elevated Idle Control (SEIC) PTO Operating Modes

### Models Affected

F-650/F-750 Medium Duty  
6.7L Diesel  
MY2024+

### General System Behavior (Continued)

- Correlation between engine speed and resistor values:
  - Normal base engine calibration allows approximately +/-50 RPM fluctuation. If any factory vehicle accessories are used during SEIC, e.g. A/C, defroster, etc., then that fluctuation may increase to approximately +/-100 RPM or more.
  - The sudden loss of aftermarket PTO hydraulic pressure during SEIC/PTO operation, like a ruptured hose, may send SEIC engine speed to near 3000 RPM. It is recommended that a hydraulic pressure switch linked to SEIC/PTO be added to disable SEIC/PTO when a hose ruptures.
  - Because of a service brake circuit characteristic at engine-start, invoking SEIC may cause the diagnostic error code FFG\_BOO to get flagged (recorded in the PCM). To avoid this, simply tap the service brake pedal sometime after engine-start and prior to invoking SEIC. Once the code is set, SEIC may not be available until it is erased.

### Special Situations

Stationary mode and Live Drive operations are supported.

### Stationary Mode

Operates in Park at elevated engine speed. The maximum load at the transmission PTO gear is 300 lb-ft [406.75 N-m].

### Mobile Mode

Operates in all gears and all vehicle speeds. The engine idle speed is slightly elevated, but peak engine speed is not limited beyond normal operating ranges. An additional rev limiter may be required to prevent over speed damage to attached pumps and equipment. The maximum load allowable for mobile mode is 200 lb-ft [271.16 N-m] at the transmission PTO gear. If the PTO feature is used for extended periods of time without vehicle movement it is recommended to switch to Stationary Mode.

### Adaptive Cooling

Adaptive cooling automatically restricts engine power when it senses an over-temperature condition and may interrupt the SEIC-PTO operation. Typically, the over-temperature condition it reacts to will also show up on the temperature gage on the instrument panel. Elevated engine speed, typical of SEIC operation, may help avoid Adaptive Cooling occurrence due to the resultant additional engine and transmission coolant flow. However, depending on the auxiliary PTO power being demanded, 900 RPM may not be enough to prevent the power train from entering Adaptive Cooling mode, but 1500 RPM may.

---

Reference Ford Body Builder website for most up-to-date information at <https://www.fordbbas.com/>

## TorqShift® HD 10R140 Transmission – Stationary Elevated Idle Control (SEIC) PTO Operating Modes

### Models Affected

F-650/F-750 Medium Duty

6.7L Diesel

MY2024+

### Stationary Elevated Idle Control (SEIC)

- A power train control module (PCM) strategy that provides elevated engine speed to drive auxiliary commercial equipment such as hydraulic pumps, generators, air compressors; or maintain vehicle battery charge under extreme electrical demands.
- SEIC is standard in all PCM's for F-650/F-750 trucks.

### Customer Access Circuit/SEIC Wire Locations

SEIC circuits, Customer Access Signal Circuits.

### Customer Access Wires for SEIC and VSO/CTO/PARK Signals

- The final stage manufacturer or up-fitter is required to supply the customer interface equipment.
- Additional information in the “Circuit Descriptions” section.
- SEIC Circuits are now located underhood on the Driver's Side as shown in the picture below.

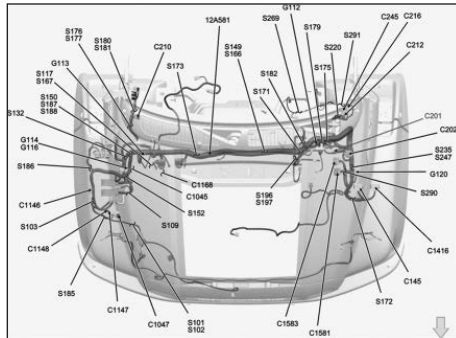

### Transmission Power Take-Off (PTO) Gear and Port

- Available on F-650/750.
- Available for TorqShift™ 10-speed automatic transmission by ordering “Transmission Power Take-Off Provision”. The PTO gear is direct splined to the torque converter impeller.
- NEVER use any sealer, especially silicone-based, on the PTO port gasket.
- TorqShift™ Automatic Transmission: On the 6.7L diesel engine, the PTO gear delivers up to 300 lb-ft [406.75 N-m] of torque to the aftermarket PTO. The powertrain cooling system can manage the heat of 60 HP on the 6.7L diesel engine during continuous operation. Higher horsepower can be delivered, but for shorter durations depending on the amount of power required.

Reference Ford Body Builder website for most up-to-date information at <https://www.fordbbas.com/>

## TorqShift® HD 10R140 Transmission – Stationary Elevated Idle Control (SEIC) PTO Operating Modes

### Models Affected

F-650/F-750 Medium Duty

6.7L Diesel

MY2024+

PTO Mode Specifications				
Engine	Mode	Max. Load at Transmission PTO Gear	Minimum Engine RPM	Maximum Engine RPM
6.7L Diesel	Stationary	300 lb-ft [406.75 N-m]	900	3000
	Mobile	200 lb-ft [271.16 N-m]	750	3000

### Stationary Elevated Idle Control mode

- Operates in Park at elevated engine speed. The maximum load at the transmission PTO gear are shown in the table below:

- Intended to be commanded ONLY by applying battery voltage to certain customer-access blunt-cut wire

Engine	Max. Load at Transmission PTO Gear, Stationary
6.7L Diesel	300 lb-ft [406.75 N-m]

circuits, and adding a target-speed resistor, and is only available when the vehicle road speed signal is zero.

- Includes a circuit which changes from open circuit to ground when enablers are met that may be used to turn on an indicator lamp while providing battery power to an aftermarket PTO clutch or solenoid.

### Engine speed ramp-rates are configurable, by means of an IDS tool, for all powertrains

- Default ramp-rate for all powertrains is 200 RPM/second.
- Configurable ramp rates are as follows:
  - DIESEL: 100 – 800 RPM/sec (in 100 RPM/second increments)

### Typical SEIC Engagement Sequence for TorqShift™ PTO

1. 12VDC is applied to **PTQ REQ1** circuit.
2. PCM looks for the following enabling conditions:
  - Parking brake applied
  - Foot off of service brake
  - Vehicle in PARK (or NEUTRAL)
  - Foot off of accelerator pedal
  - Vehicle speed is 0 mph (stationary)
  - Engine at a stable base idle speed
  - Transmission Oil Temp above 20°F
  - 6.7L only - Engine Coolant Temperature (ECT) 20°F minimum

Reference Ford Body Builder website for most up-to-date information at <https://www.fordbbas.com/>

**TorqShift® HD 10R140 Transmission – Stationary Elevated Idle Control (SEIC)  
PTO Operating Modes**

**Models Affected**

F-650/F-750 Medium Duty  
6.7L Diesel  
MY2024+

**Typical SEIC Engagement Sequence for TorqShift™ PTO (Continued)**

3. Command is sent to boost the transmission hydraulic line pressure to a minimum of 200 PSI, which is used by the aftermarket PTO supplier to hold their PTO Clutch. Command is sent to increase engine speed to 900 RPM.
4. The PTO RLY circuit changes from open circuit to ground. This will provide battery voltage to the aftermarket PTO solenoid to engage the PTO.
5. Engine RPM ramps to target speed determined by the resistor selection.

**Mobile Mode**

- Operates in all gears and all vehicle speeds. The engine idle speed is elevated to 750 RPM when the Mobile Mode is initiated.

Engine RPM is controlled by the driver through the throttle pedal and is limited to upfitter selected peak engine speed

- RPM limiting (2018 model year and later 6.7L diesel vehicles only).
- RPM limiting controls engine speed in Mobile Mode below a selectable maximum threshold. Maximum RPM is determined by the resistor installed between the PTO\_REF and PTO RPM circuits.

See table for RPM/resistor values.

- Transmission behavior changes in Mobile Mode due to upshifting performance; e.g., it is possible for a customer to reach maximum RPM in a lower gear, and the transmission is unable to accelerate – or upshift – to the next gear.
- If this action is not desired, the operator can
  1. Ease up on the accelerator pedal and receive an upshift, or
  2. Put the transmission in manual mode and select the gears manually.
- Selected target RPM has a margin of +/- 15% based on transient conditions (for example, descending a grade).
- Mobile PTO may overshoot the selected RPM by 100-200 RPM for drivability.

The Maximum load allowable for mobile mode are shown in the table below

Engine	Max. Load at Transmission PTO Gear, Mobile Mode
6.7L Diesel	200 lb-ft [271.16 N-m]

- If the PTO feature is used for extended periods of time without vehicle movement it is recommended to switch to Stationary Mode.

**Reference Ford Body Builder website for most up-to-date information at <https://www.fordbbas.com/>**

## **TorqShift® HD 10R140 Transmission – Stationary Elevated Idle Control (SEIC) PTO Operating Modes**

### **Models Affected**

F-650/F-750 Medium Duty

6.7L Diesel

MY2024+

### **Typical Mobile Mode Engagement Sequence**

1. 12VDC applied to PTO REQ2 circuit.
2. PCM looks for the following enabling conditions:
  - Transmission Oil Temp above 20°F
  - 6.7L only - Engine Coolant Temperature (ECT) 20°F minimum
3. PCM looks for voltage on PTO RPM circuit.
4. Command is sent to boost transmission hydraulic line pressure to a minimum of 200 PSI, which is used by the aftermarket PTO supplier to hold their PTO Clutch.
5. The PTO RLY circuit changes from open circuit to ground. If the up-fitter uses the circuit wiring offered in this bulletin then this will provide battery voltage to the aftermarket PTO solenoid to engage the PTO.
6. Engine idle increases to 750 RPM.

Reference Ford Body Builder website for most up-to-date information at <https://www.fordbbas.com/>

---

## TorqShift® HD 10R140 Transmission – Stationary Elevated Idle Control (SEIC) PTO Operating Modes

### Models Affected

F-650/F-750 Medium Duty  
6.7L Diesel  
MY2024+

### Battery Charge Protect (BCP):

- When 12VDC is applied to the BCP SW circuit, the engine speed goes immediately to 600. From this state, the PCM uses battery voltage, as well as ambient air temperature, and engine oil temperature information to raise engine speed higher to maintain battery charge. Maximum engine speed in BCP mode is 1200 RPM. Loss of an operating condition after BCP is engaged will require the BCP switch to be cycled before BCP will re-engage.
- BCP CANNOT BE ACTIVE WHEN SEIC OR PTO MODES ARE ACTIVE.
- A Resistor must be installed between PTO REF and PTO RPM for Diesel engines. See Appendix A for resistor selection (See pages 58-59).

### Typical Battery Charge Protect Mode

#### Engagement Sequence:

1. 12VDC applied to BCP SW circuit.
2. PCM looks for the following enabling conditions:
  - Parking brake applied
  - Foot off of service brake
  - Vehicle in PARK (or NEUTRAL)
  - Foot off of accelerator pedal
  - Vehicle speed is 0 mph (stationary)
  - Engine at a stable base idle speed
  - Transmission Oil Temp above 20°F
  - 6.7L only - Engine Coolant Temperature (ECT) 20°F minimum
3. PCM looks for a valid voltage between 0.2 to 4.7 Volts on the PTO RPM circuit.
4. Vehicle idle fluctuates slightly as PCM enters BCP mode.
5. The BCP LP circuit changes from open circuit to ground. This is intended to provide a ground path for a BCP indicator lamp.

**NOTE:** BCP is a smart system. Engine idle will not increase unless the vehicle senses an increase in electrical demand. Under periods of low electrical demand, the operator may not notice any change in engine RPM. It is recommended that the modifier install an indicator lamp to alert the operator that BCP is properly engaged.

### Additional notes:

#### Adaptive Cooling

This PCM strategy automatically restricts engine power when it senses an over-temperature condition and may interrupt the SEIC-PTO operation. Typically, the over-temperature condition it reacts to will also show up on the temperature gage on the instrument panel. Elevated engine speed, typical of SEIC operation, may help avoid Adaptive Cooling occurrence due to the resultant additional engine and transmission coolant flow. However, depending on the auxiliary PTO power being demanded, 900 RPM may not be enough to prevent the power train from entering Adaptive Cooling mode, but 1500 RPM may.

#### Input Resistor

ALL modes (SEIC, PTO) require usage of an input resistor. The resistor value may be obtained from Appendix A (See pages 58-59).

Reference Ford Body Builder website for most up-to-date information at <https://www.fordbbas.com/>

## TorqShift® HD 10R140 Transmission – Stationary Elevated Idle Control (SEIC) PTO Operating Modes

### Models Affected

F-650/F-750 Medium Duty

6.7L Diesel

MY2024+

Vehicle Conditions to Enable SEIC (all are required)	Vehicle Conditions that Disable SEIC (any one required - See Note-1)	SEIC	Mobile Mode	BCP
Parking brake applied	Parking brake disengaged	Yes	No	Yes
Foot off of service brake	Depressing service brake	Yes	No	Yes
Vehicle in PARK (or NEUTRAL)	Vehicle take out of PARK (or NEUTRAL)	Yes	No	Yes
Foot off of accelerator pedal	Accelerator pedal depressed	Yes	No	Yes
Vehicle speed is 0 mph (stationary)	Vehicle speed is not 0 mph (stationary)	Yes	No	Yes
Engine at a stable base idle speed		Yes	No	Yes
Transmission Oil Temp above 20°F	Transmission Oil Temperature (TOT) exceeds 240°F	Yes	Yes	Yes
	Catalyst Temperature Limit	Yes	Yes	Yes

**NOTE 1:** A “change-of-state” at the **PTO REQ1** input (for Stationary Elevated Idle Control non-Split Shaft), or for both **PTO REQ1** and **PTO REQ2** inputs (\*for Stationary Elevated Idle Control Split Shaft) is required to re-invoke Stationary Elevated Idle Control. When a disable is seen by the PCM, the Stationary Elevated Idle Control function is deactivated, the **PTO RLY** output circuit changes from a “ground-source” to “open circuit”, and engine speed returns to base idle. To re-activate Stationary Elevated Idle Control, the operator must open the PTO Switch to the **PTO REQ1** and **PTO REQ2** inputs, then close the PTO Switch again to the **PTO REQ1** or **PTO REQ1** and **PTO REQ2** inputs.

**NOTE 2:** A “change-of-state” at the **PTO REQ2** input is required to re-invoke Mobile PTO. When a disable is seen by the PCM, the Mobile PTO function is deactivated, the **PTO RLY** output circuit changes from a “ground-source” to “open circuit”, and engine speed returns to base idle. To re-activate Mobile PTO, the operator must open the PTO Switch to the **PTO REQ2** input, then close the PTO Switch again to the **PTO REQ2** input.

**NOTE 3:** A “change-of-state” at the **BCP SW** input is required to re-invoke Battery Charge Protect. When a disable is seen by the PCM, the Battery Charge Protect function is deactivated, the **BCP LP** output circuit changes from a “ground-source” to “open circuit”, and engine speed returns to base idle. To re-activate Battery Charge Protect, the operator must open the Battery Charge Protect Switch to the **BCP SW** input, then close the Battery Charge Protect Switch again to the **BCP SW** input.

\*We presently do not offer a Split Shaft option for this platform. Please reference Ford's Body Builder website for additional Split Shaft information.

Reference Ford Body Builder website for most up-to-date information at <https://www.fordbbas.com/>

## Medium Duty F-650/F-750 6.7L Diesel MY2024+ PTO Installation – Overview

1. Refer to [pages 44-49](#) of this manual for PTO installation.
2. Directly connected hoses must be routed away from exhaust and rotating components.
3. After wiring harness is connected to PTO solenoid valve and pressure switch, ensure harness has sufficient clearance from exhaust pipe, and all rotating components.

## Medium Duty F-650/F-750 6.7L Diesel MY2024+ PTO Installation

**CAUTION:** Always wear suitable Personal Protective Equipment (PPE) when installing the PTO. Safety glasses and gloves are recommended.

**Overview:** The 810 Series PTO has a single housing for all configurations. There is no separate geared adapter.

1. If NVH Cover is installed over PTO opening, cut away portion of the cover as described in Ford SVE Bulletin Q-300 (available at [www.fordbbas.com](http://www.fordbbas.com), **(Fig. 28)**). Exercise caution when removing cover. Avoid any damage or severing of transmission, wiring, and fluid lines.

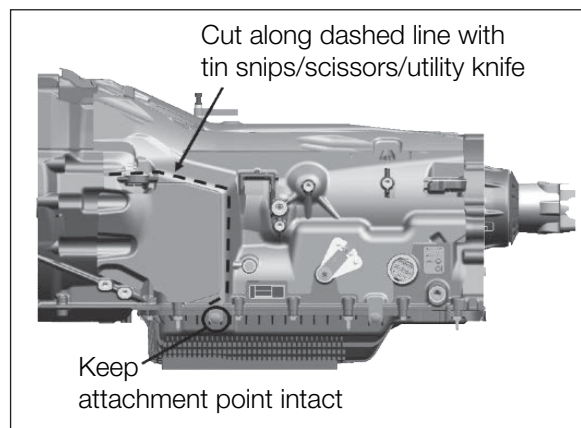

Figure 28

2. Install the PTO pressure switch onto port on the hydraulic valve cap. Torque to 10-12 lb-ft [13-16 N-m] **(Fig. 29)**.



Figure 29

## Medium Duty F-650/F-750 6.7L Diesel MY2024+ (Continued)

### PTO Installation (Continued)

- Remove the plug from the transmission pressure port (**Fig. 30**) and install fitting 380750 in the opening (**Fig. 32**). Torque to 10-12 lb-ft [13-16 N-m]. See (**Fig. 31**) for recommended fitting orientation.

**IMPORTANT:** Both washers (captive and loose) and the O-ring must be present at installation. The second washer must fit around the O-ring for proper seal (**Fig. 32**).

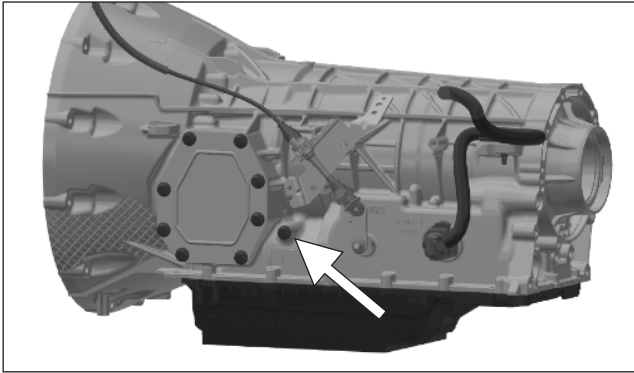

Figure 30

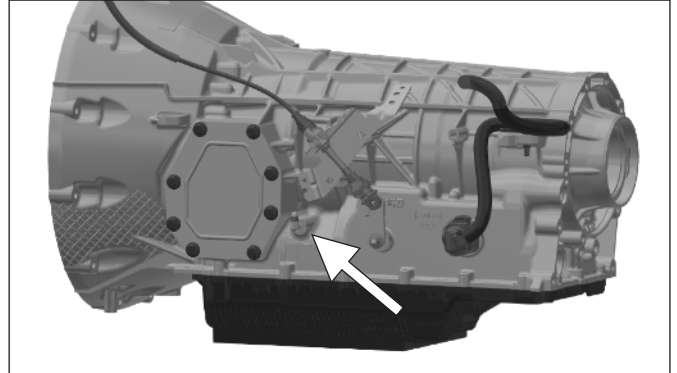

Figure 31

#### PTO Pressure/Lube Fitting & Hose:

- 380750 90-degree Adapter Fitting (1 each) (**Fig. 32**).  
329784-3X Hose Assembly (1 each) (**Fig. 33**).



Figure 32

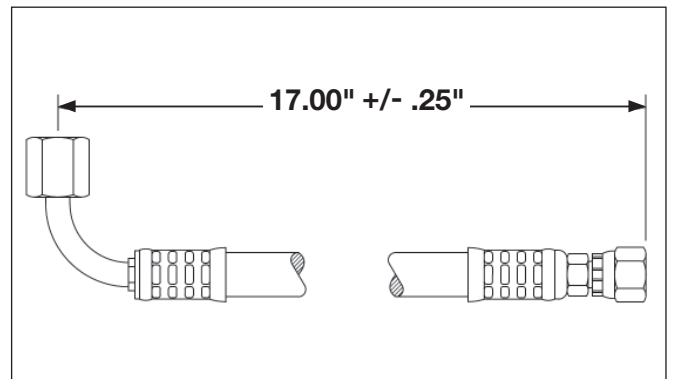

Figure 33

- Remove and discard the PTO aperture cover plate and gasket. Do not use this gasket when installing the PTO (**Fig. 34** and **Fig. 35**).

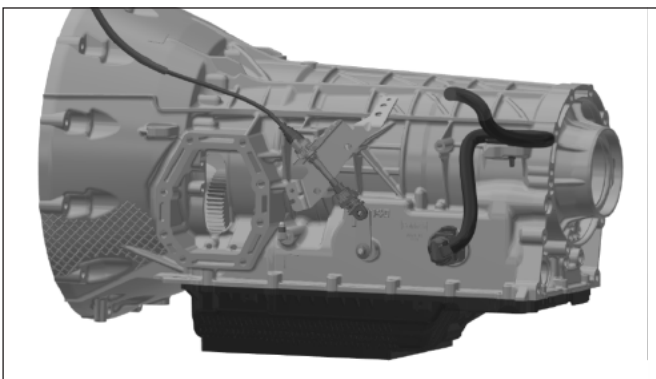

Figure 34

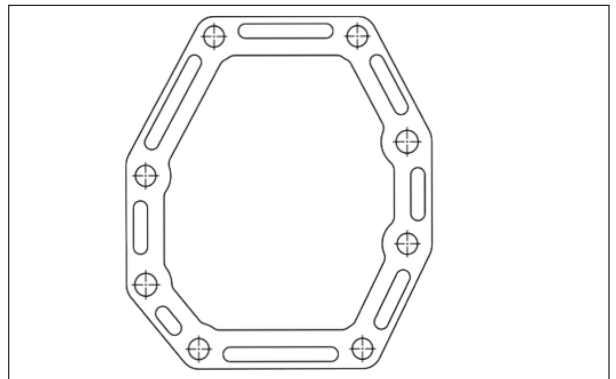

Figure 35

## Medium Duty F-650/F-750 6.7L Diesel MY2024+ (Continued) PTO Installation (Continued)

**CAUTION:** Over tightening the mounting hardware may damage the transmission threads.

5. Install spring bushings into the PTO mounting plate protruding to rear.
  
6. Install 35-P-136 gasket and mounting plate using:  
(4) M10 x 35 socket head cap screws,  
torque to 50-55 lb-ft [67-75 N-m] (**Fig. 36**).

**NOTE:** Do not use sealing compounds because they are generally incompatible with automatic transmission fluids and could possibly contaminate valve bodies in the transmission.

- 6a. Install studs and 8 mm dowel pins into mounting plate. Thread studs until hand tight (**Fig. 37**).

7. Mount PTO onto mounting plate with 35-P-137-X gasket and:  
(4) M10 x 45 flange head cap screws,  
torque to 50-55 lb-ft [67-75 N-m]  
(2) 3/8"-16 flange head cap screws,  
torque to 30-35 lb-ft [41-47 N-m]  
(2) 3/8" flange nuts,  
torque to 35-40 lb-ft [47-54 N-m] (**Fig. 38**).

**NOTE:** Always torque fasteners in a crossing pattern.



Figure 36

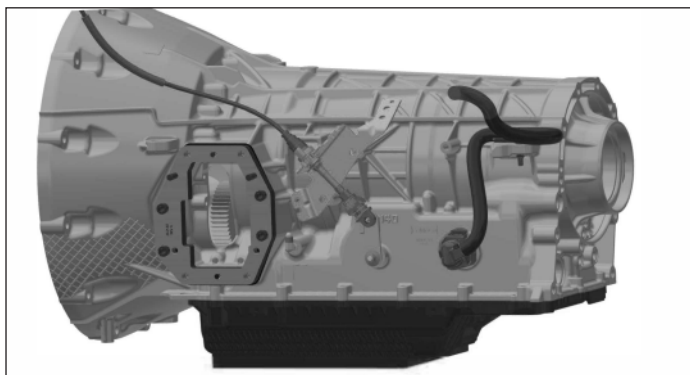

Figure 37

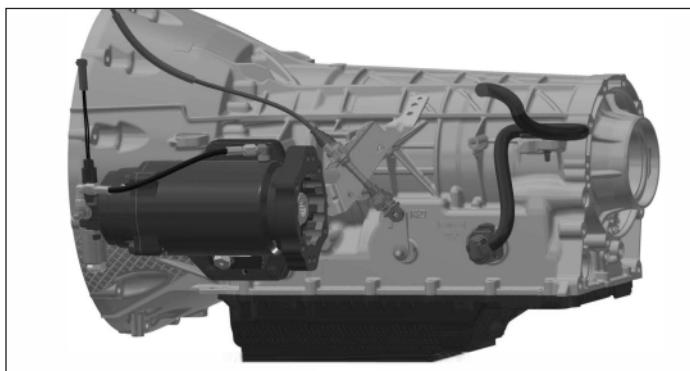

Figure 38

## Medium Duty F-650/F-750 6.7L Diesel MY2024+ (Continued)

### PTO Installation (Continued)

8. Connect hose to the fitting on the transmission. Chelsea recommends all hoses be routed above the PTO as shown in **(Fig. 39)**. Some large pumps may require lube hose to be routed below the PTO due to clearance to the transmission fitting. Hold hose fitting in desired position and tighten lock nut with a wrench until solid feeling is encountered. From that point, apply one-sixth turn. Next, connect the other end of the hose to fitting on the PTO valve cap. Tighten until solid feeling is encountered. From that point, apply one-sixth turn.
9. Connect wiring harness as shown on [pages 50-57](#).
10. If installing a Chelsea Pump, torque pump's mounting bolts to 24 lb-ft [33 N-m].
11. Check backlash and change gasket as appropriate.
12. Check transmission oil level per Ford guidelines.

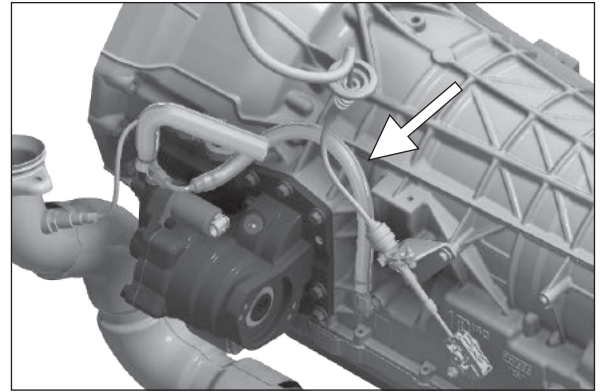

Figure 39

**! WARNING:** Oil may be hot. Use extreme caution to assure that you do not accidentally come in contact with hot oil.

**! WARNING:** Installers MUST secure all wiring and hoses with maximum possible clearance from exhaust so there is no contact with exhaust while in operation.

**! This symbol warns of possible personal injury.**

## Checking Backlash

To check for proper backlash on PTOs without a shift cover:

1. Remove EOC port plug (**Fig. 40**).
2. Mount a lever-style dial indicator so that it registers movement of the input gear (driven gear) of the PTO (**Fig. 41**).

**NOTE:** For proper location of dial indicator contact point see (**Fig. 42**).

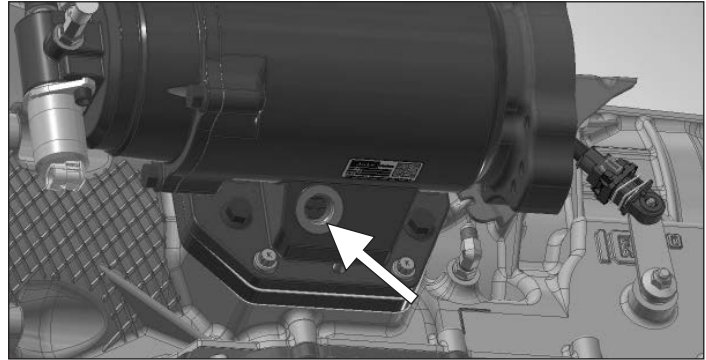

Figure 40

3. Gently rotate the PTO output back and forth with your hand to cause the input gear to move. Note the total movement of the input gear on the dial indicator.
4. Establish backlash at .006"-.012" [.15 mm-.30 mm] by adding or subtracting gaskets.

**General rule: A Chelsea .010" gasket will change backlash approximately .006". A .020" gasket changes backlash approximately .012".**

5. Replace the EOC port plug and re-torque to 25-30 lb-ft [34-41 N-m].

### For reference only:

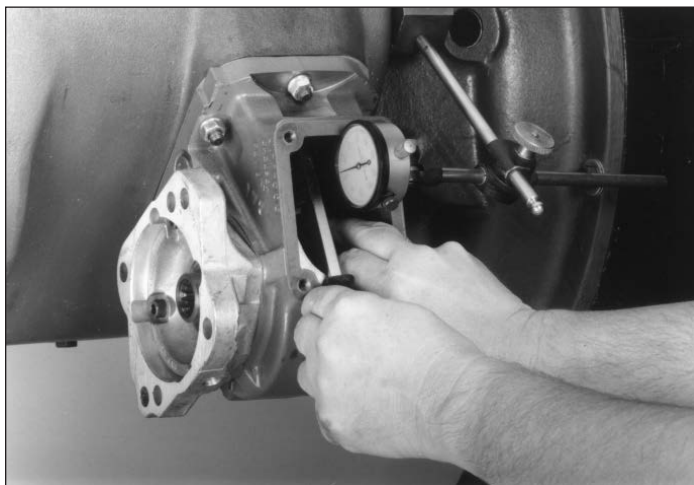

Figure 41

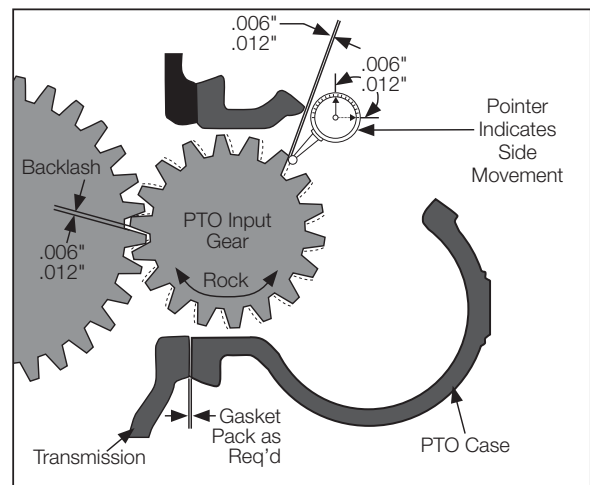

Figure 42

---

## Transmission/PTO Electrical Operation

1. When vehicle is on, power is supplied to switch via **12VDC IGN**.
2. Switch illumination is controlled by **Light Control**. When PTO pressure switch closes (PTO is engaged), **Light Control** will be connected to ground via vehicle ground and the light will illuminate independent of on/off status of switch. A high-quality ground connection is important to prevent electrical errors that may be difficult to diagnose.
3. When switch is toggled on, power is supplied via **Power Out** to **PTO REQ**. The relay will not actuate because the Ford power control module (PCM) has blocked the **PTO RLY** connection from receiving power until it is ready.
4. When the PCM gets voltage at **PTO REQ**, initiates SEIC mode. This may include adjustment of the idle speed, cooling parameters, and transmission line pressure, depending on the selected mode. **NOTE that the mode is selected by wiring to either Ford circuit PTO REQ1 or PTO REQ2**. The vehicle may fail to enter PTO mode if any of several safeguards not met. See Ford Body Builder's Guide for detailed information on these limitations.
5. If all checks are successful, transmission will enter PTO mode and increase hydraulic line pressure to 200 PSI for PTO clutch operation. Engine speed will also ramp to minimum required by operational mode. If PTO mode cannot be enabled, no changes will occur.
6. For SEIC operation, the engine speed will ramp to the level determined by the potentiometer circuit. The PCM outputs a reference voltage to **PTO REF** and provides a ground signal at **PTO RTN**. The potentiometer is used as a voltage divider; adjusting it clockwise reduces the voltage measured at **PTO RPM** (and vice versa). The voltage measured by the PCM at **PTO RPM** is used to set the SEIC speed relative to the minimum and maximum speeds allowed by Ford. Consult the Ford Body Builder's Guide for correlations of voltage and SEIC RPM.
7. The PCM connects the **PTO RLY** connection to ground, which allows power to flow through the relay control circuit to close the relay. Once closed, the relay sends power to the PTO solenoid valve to actuate and engage the PTO.
8. PTO will continue to operate until any safeguard is violated and PTO mode is forcibly disabled by the PCM, or the PTO switch is toggled to cut power to the PTO system. If PTO mode is forcibly disabled, the PTO switch will need to be toggled after the error is resolved to re-enter PTO mode.

**Wiring Installation (Shift Option B)  
 F-650/F-750 6.7L Diesel MY2024+  
 w/o Electronic Overspeed Control (EOC)  
 810 Series**

**(SK-658 Rev B)**

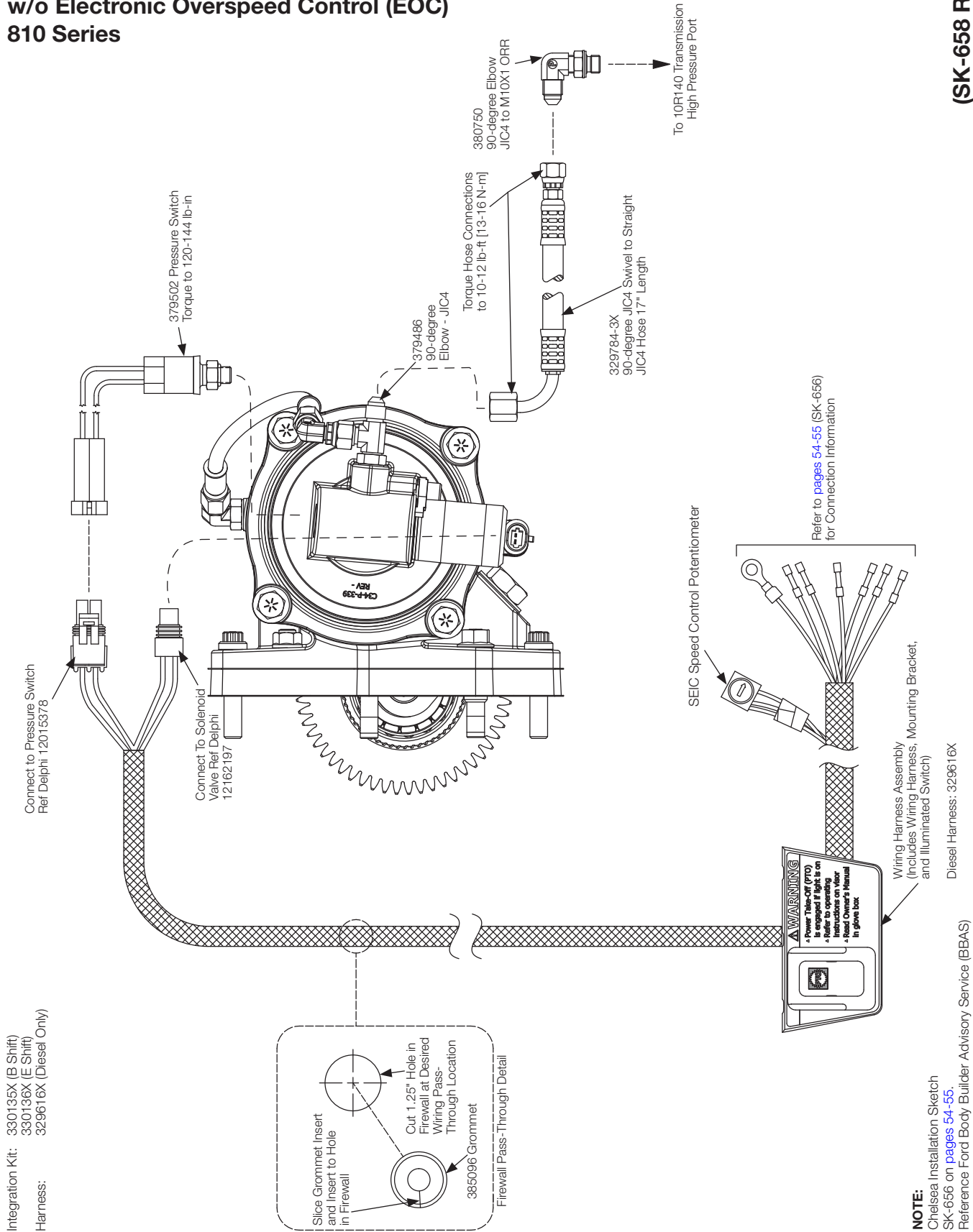

**Wiring Installation Chart (Shift Option B)**  
**F-650/F-750 6.7L Diesel MY2024+**  
**w/o Electronic Overspeed Control (EOC)**  
**810 Series**

**(SK-658 Rev B)**

Medium Duty F-650/F-750 6.7L Diesel MY2024+ w/ TorqShift® HD 10R140 Transmission							
Chelsea PTO Wire Color		Blunt cut wires found on Driver Side behind Data Link					
		Stationary Mode			Mobile Mode		
		Function	Ford Wire Color	Circuit	Function	Ford Wire Color	Circuit
329616X Wiring Harness (Shift Option B)	Purple	12VDC Power	Gray	CBK03	12VDC Power	Gray	CBK03
	Yellow	PTO REQ1	Yellow/Green	CE912	PTO REQ1	NOT USED	
	Yellow	PTO REQ2	NOT USED		PTO REQ2	Blue/Orange	CE933
	White	PTO REF	White/Brown	LE434	PTO REF	White/Brown	LE434
	Green	PTO RPM	Green	CE914	PTO RPM	Green	CE914
	Grey	PTO RTN	Gray/Red	RE327	PTO RTN	Gray/Red	RE327
	Blue/White	PTO RLY	Blue/White	CE326	PTO RLY	Blue/White	CE326

**NOTE:** See Appendix B for additional information regarding the description of Ford circuits listed above (See page 60).

**Mobile to Stationary Switch**

1. If required for your application a Single Pole Double Throw (SPDT) switch can be installed in the cab to control PTO function between Mobile Mode and SEIC Stationary Mode. Connect the Chelsea YELLOW wire as illustrated below.

**Switching Between Stationary and Mobile**

**To switch between Mobile & Stationary Mode – Install a Single Pole Double Throw (SPDT) switch as shown:**

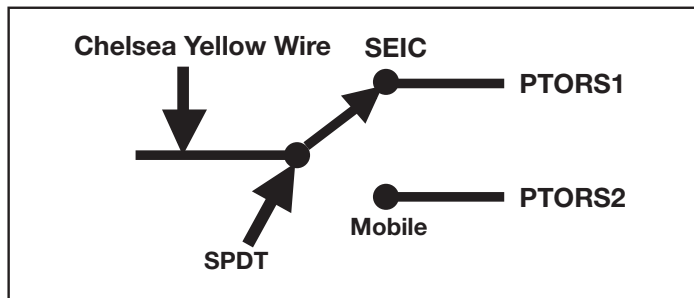



**Wiring Installation Chart (Shift Option K)**  
**F-650/F-750 6.7L Diesel MY2024+**  
**w/ Electronic Overspeed Control (EOC)**  
**810 Series**

**(SK-660 Rev B)**

Medium Duty F-650/F-750 6.7L Diesel MY2024+ w/ TorqShift® HD 10R140 Transmission							
Chelsea PTO Wire Color		Blunt cut wires found on Driver Side behind Data Link					
		Stationary Mode			Mobile Mode		
		Function	Ford Wire Color	Circuit	Function	Ford Wire Color	Circuit
329617X Wiring Harness (Shift Option K)	Red	12VDC Power	Gray	CBK03	12VDC Power	Gray	CBK03
	Yellow	PTO REQ1	Yellow/Green	CE912	PTO REQ1	NOT USED	
	Yellow	PTO REQ2	NOT USED		PTO REQ2	Blue/Orange	CE933
	White	PTO REF	White/Brown	LE434	PTO REF	White/Brown	LE434
	Green	PTO RPM	Green	CE914	PTO RPM	Green	CE914
	Grey	PTO RTN	Gray/Red	RE327	PTO RTN	Gray/Red	RE327
	Blue/White	PTO RLY	Blue/White	CE326	PTO RLY	Blue/White	CE326

**NOTE:** See Appendix B for additional information regarding the description of Ford circuits listed above (See page 60).

**Mobile to Stationary Switch**

1. If required for your application a Single Pole Double Throw (SPDT) switch can be installed in the cab to control PTO function between Mobile Mode and SEIC Stationary Mode. Connect the Chelsea YELLOW wire as illustrated below.

**Switching Between Stationary and Mobile**

**To switch between Mobile & Stationary Mode – Install a Single Pole Double Throw (SPDT) switch as shown:**

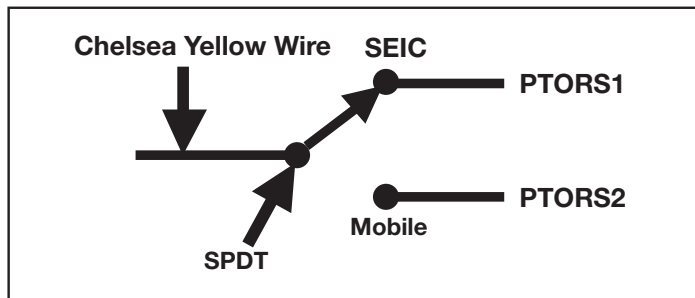

**Wiring Installation (Shift Option B)**  
**F-650/F-750 6.7L Diesel MY2024+**  
**w/o Electronic Overspeed Control (EOC)**  
**810 Series**

**(SK-656 Rev B)**

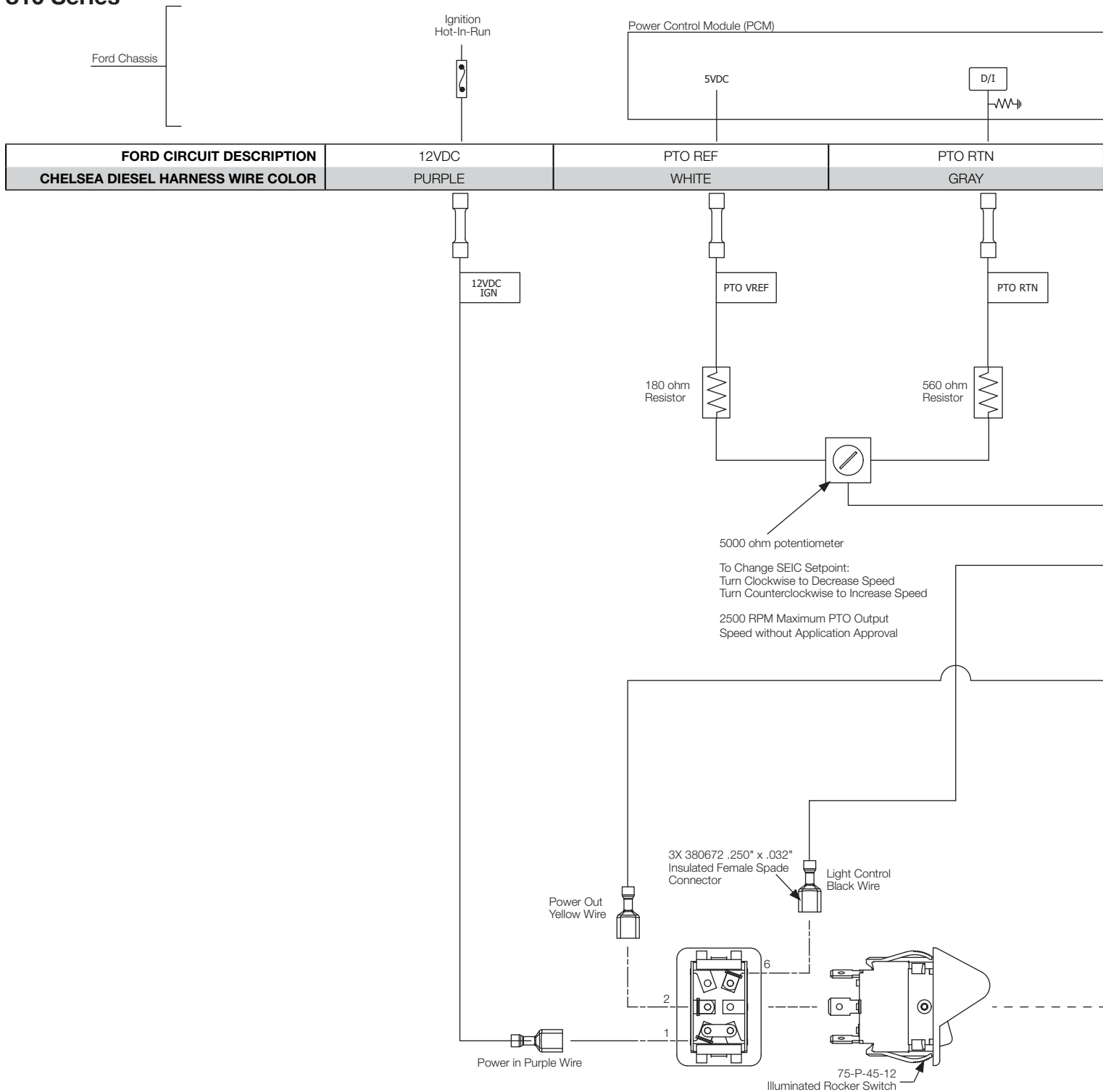

Please reference the most current edition of Ford's Body Builder Layout Book for Medium Duty F-Series at [www.fordbbas.com](http://www.fordbbas.com)

**Wiring Installation (Shift Option B)**  
**F-650/F-750 6.7L Diesel MY2024+**  
**w/o Electronic Overspeed Control (EOC)**  
**810 Series**

(SK-656 Rev B)

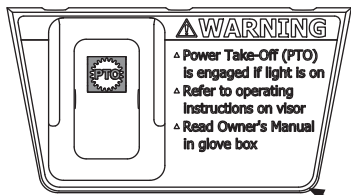
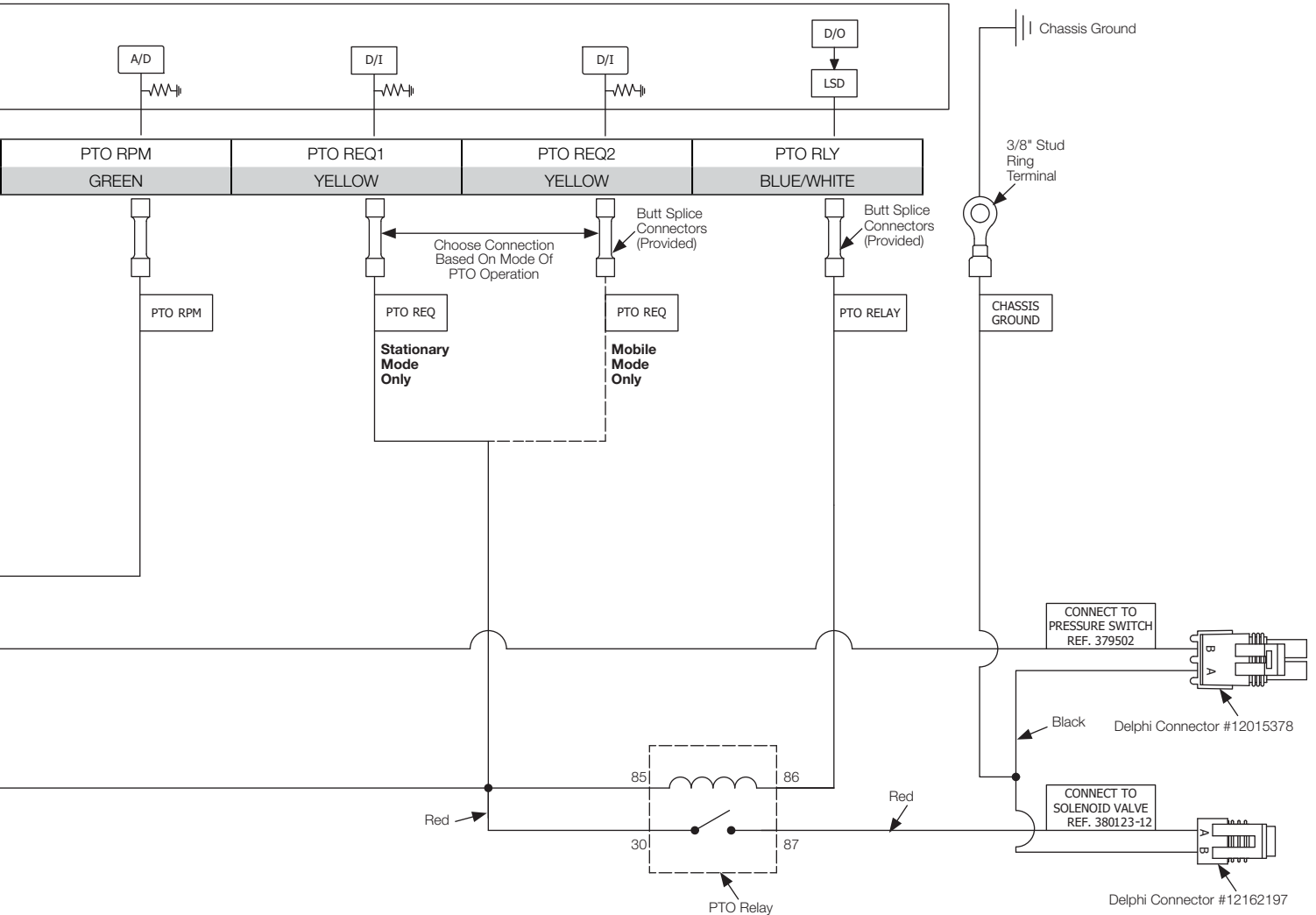

380668X  
Bracket Assembly

**NOTES:**

- 1) All Chelsea Harness Wire is 18 AWG.
- 2) Potentiometer is Preset to Furthest Clockwise Position (Minimum Speed).
- 3) Relay is Secured to Reverse of Bracket (Non EOC Only).
- 4) Refer to Ford SVE Bulletin Q-256.

Please reference the most current edition of Ford's Body Builder Layout Book for Medium Duty F-Series at [www.fordbbas.com](http://www.fordbbas.com)

**Wiring Installation (Shift Option K)  
 F-650/F-750 6.7L Diesel MY2024+  
 w/ Electronic Overspeed Control (EOC)  
 810 Series**

**(SK-656 Rev B)**

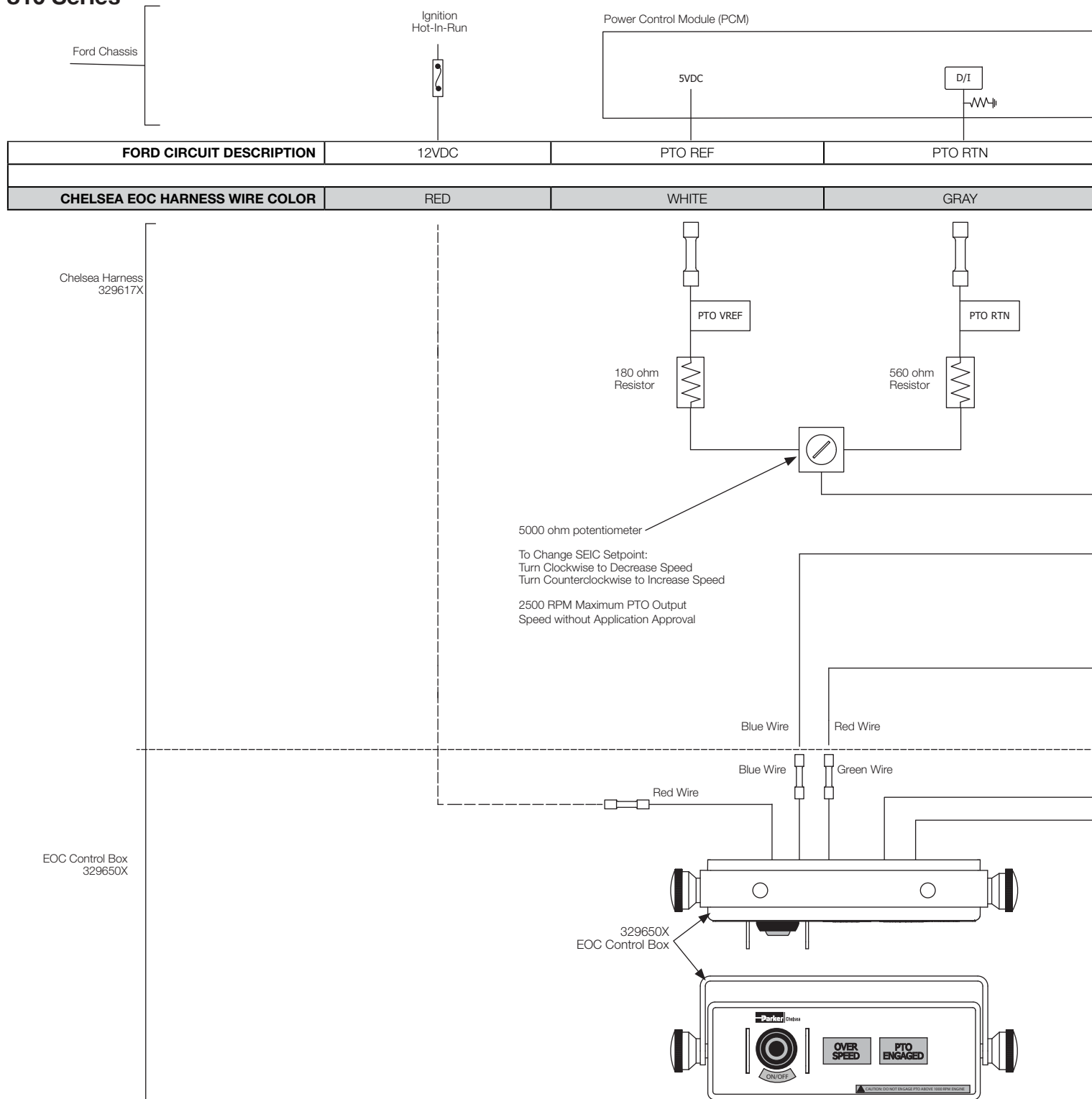

Please reference the most current edition of Ford's Body Builder Layout Book for Medium Duty F-Series at [www.fordbbas.com](http://www.fordbbas.com)

**Wiring Installation (Shift Option K)  
 F-650/F-750 6.7L Diesel MY2024+  
 w/ Electronic Overspeed Control (EOC)  
 810 Series**

**(SK-656 Rev B)**

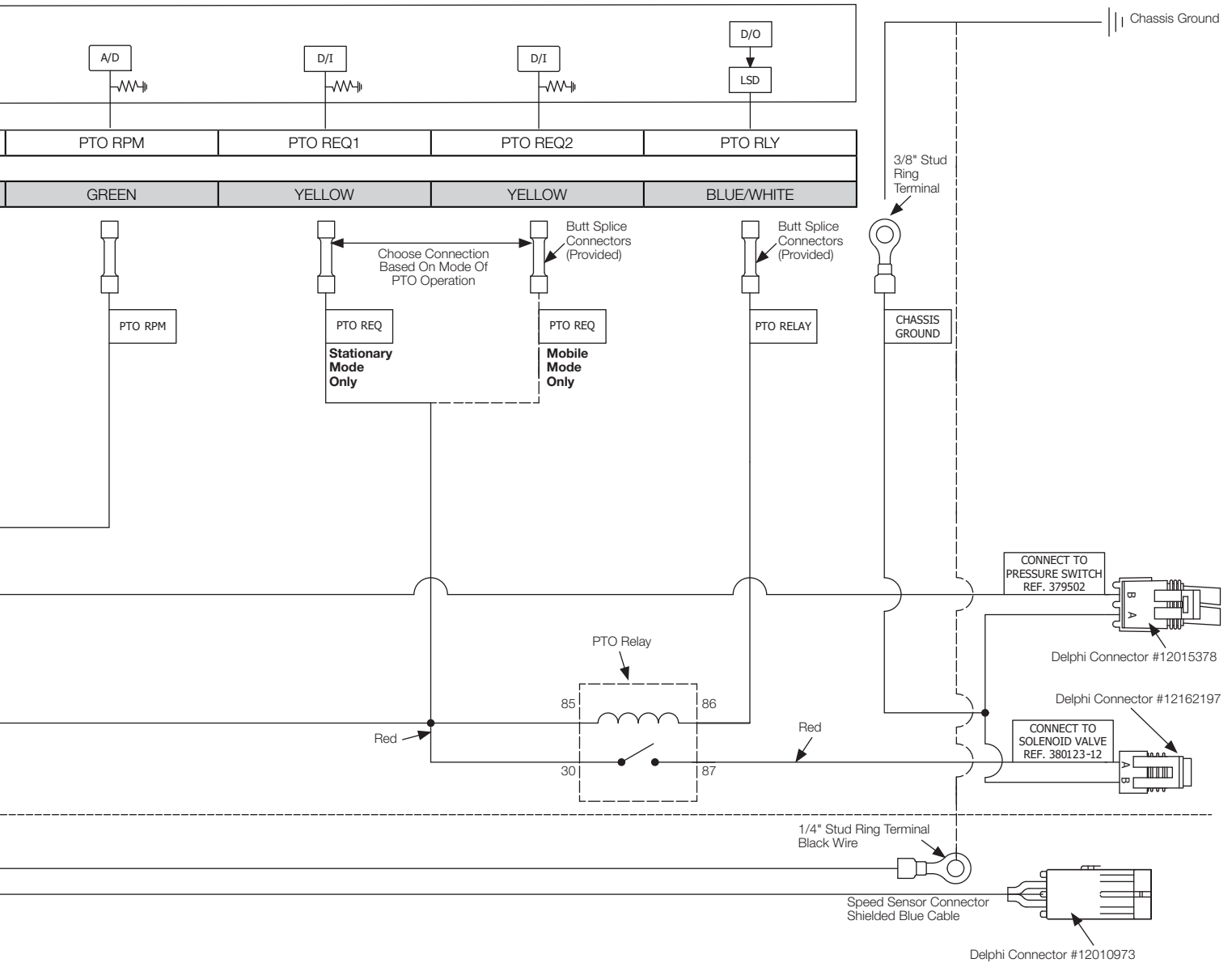

**NOTES:**

- 1) All Chelsea Harness Wire is 18 AWG.
- 2) Potentiometer is Preset to Furthest Clockwise Position (Minimum Speed).
- 3) Relay is Secured to Reverse of Bracket (Non EOC Only).
- 4) Refer to Ford SVE Bulletin Q-256.

Please reference the most current edition of Ford's Body Builder Layout Book for Medium Duty F-Series at [www.fordbbas.com](http://www.fordbbas.com)

Appendix A: Resistor Tables

	PTO_RPM Input Voltage	Resistor $\Omega$	DIESEL			
			SEIC PTO	*Split Shaft PTO	Mobile PTO	Mobile PTO
			Engine RPM	Engine RPM	Engine RPM Speed Limit	Engine Base Idle Speed (Minimum)
Voltage Out-Of-Range LOW	0.00	N/A	N/A	N/A	N/A	N/A
	0.10	N/A	N/A	N/A	N/A	N/A
	0.20	N/A	N/A	N/A	N/A	N/A
Voltage Dead Band	0.30	73,633	900	700	900	750
Usable Voltage Range	0.40	54,050	900	700	900	750
	0.50	42,300	953	758	953	750
	0.60	34,467	1,005	815	1,005	750
	0.70	28,871	1,058	873	1,058	750
	0.80	24,675	1,110	930	1,110	750
	0.90	21,411	1,163	988	1,163	750
	1.00	18,800	1,215	1,045	1,215	750
	1.10	16,664	1,268	1,103	1,268	750
	1.20	14,883	1,320	1,160	1,320	750
	1.30	13,377	1,373	1,218	1,373	750
	1.40	12,086	1,425	1,275	1,425	750
	1.50	10,967	1,478	1,333	1,478	750
	1.60	9,988	1,530	1,390	1,530	750
	1.70	9,124	1,583	1,448	1,583	750
	1.80	8,356	1,635	1,505	1,635	750
	1.90	7,668	1,688	1,563	1,688	750
	2.00	7,050	1,740	1,620	1,740	750
	2.10	6,490	1,793	1,678	1,793	750
	2.20	5,982	1,845	1,735	1,845	750
	2.30	5,517	1,898	1,793	1,898	750
	2.40	5,092	1,950	1,850	1,950	750
	2.50	4,700	2,003	1,908	2,003	750
	2.60	4,338	2,055	1,965	2,055	750
	2.70	4,004	2,108	2,023	2,108	750
	2.80	3,693	2,160	2,080	2,160	750
	2.90	3,403	2,213	2,138	2,213	750
	3.00	3,133	2,265	2,195	2,265	750
	3.10	2,881	2,318	2,253	2,318	750
3.20	2,644	2,370	2,310	2,370	750	
3.30	2,421	2,423	2,368	2,423	750	
3.40	2,212	2,475	2,425	2,475	750	
3.50	2,014	2,528	2,483	2,528	750	
3.60	1,828	2,580	2,540	2,580	750	
3.70	1,651	2,633	2,598	2,633	750	
3.80	1,484	2,685	2,655	2,685	750	
3.90	1,326	2,738	2,713	2,738	750	
4.00	1,175	2,790	2,770	2,790	750	
4.10	1,032	2,843	2,828	2,843	750	
4.20	895	2,895	2,885	2,895	750	
4.30	765	2,948	2,943	2,948	750	
4.40	641	3,000	3,000	3,000	750	
Voltage Dead Band	4.50	522	3,000	3,000	10,000	750
	4.60	409	3,000	3,000	10,000	750
Voltage Out-Of-Range HIGH	4.70	N/A	N/A	N/A	N/A	N/A
	4.80	N/A	N/A	N/A	N/A	N/A
	4.90	N/A	N/A	N/A	N/A	N/A
	5.00	N/A	N/A	N/A	N/A	N/A

\*We presently do not offer a Split Shaft option for this platform. Please reference Ford's Body Builder website for additional Split Shaft information.

Please reference the most current edition of Ford's Body Builder Layout Book for Medium Duty F-Series at [www.fordbbas.com](http://www.fordbbas.com)

Appendix A: Resistor Tables (Continued)

Medium Duty F-650/F-750 6.7L Diesel MY2024+		
Non-Split Shaft Stationary		
Engine Target Speed (RPM)	Resistor (Ohms)	Voltage (volts)
900	54050	0.40
1000	35098	0.59
1100	25391	0.78
1200	19491	0.97
1300	15525	1.16
1400	12677	1.35
1500	10531	1.54
1600	8858	1.73
1700	7515	1.92
1800	6415	2.11
1900	5496	2.30
2000	4718	2.50
2100	4050	2.69
2200	3471	2.88
2300	2963	3.07
2400	2515	3.26
2500	2116	3.45
2600	1759	3.64
2700	1438	3.83
2800	1147	4.02
2900	883	4.21
3000	641	4.40

Medium Duty F-650/F-750 6.7L Diesel MY2024+		
*Split Shaft Stationary Elevated		
Engine Target Speed (RPM)	Resistor (Ohms)	Voltage (volts)
700	54050	0.40
800	36247	0.57
900	26724	0.75
1000	20795	0.92
1100	16748	1.10
1200	13810	1.27
1300	11580	1.44
1400	9830	1.62
1500	8419	1.79
1600	7258	1.97
1700	6286	2.14
1800	5460	2.31
1900	4749	2.49
2000	4132	2.66
2100	3590	2.83
2200	3111	3.01
2300	2684	3.18
2400	2301	3.36
2500	1956	3.53
2600	1644	3.70
2700	1359	3.88
2800	1099	4.05
2900	861	4.23
3000	641	4.40

Medium Duty F-650/F-750 6.7L Diesel MY2024+		
Mobile PTO Engine Speed Limit		
Engine Target Speed (RPM)	Resistor (Ohms)	Voltage (volts)
900	54050	0.40
1000	35098	0.59
1100	25391	0.78
1200	19491	0.97
1300	15525	1.16
1400	12677	1.35
1500	10531	1.54
1600	8858	1.73
1700	7515	1.92
1800	6415	2.11
1900	5496	2.30
2000	4718	2.50
2100	4050	2.69
2200	3471	2.88
2300	2963	3.07
2400	2515	3.26
2500	2116	3.45
2600	1759	3.64
2700	1438	3.83
2800	1147	4.02
2900	883	4.21
3000	641	4.40

\*We presently do not offer a Split Shaft option for this platform. Please reference Ford's Body Builder website for additional Split Shaft information.

Please reference the most current edition of Ford's Body Builder Layout Book for Medium Duty F-Series at [www.fordbbas.com](http://www.fordbbas.com)

**Appendix B: SEIC/PTO: PTO Modes Circuit Descriptions (Diesel)**

6.7L DIESEL ENGINE PCM				
Wire Color	Wire Tag	Circuit No.	Circuit Intent	Description
Yellow/Green	PTO REQ1	CE912	Input (VPWR)	<b>6.7L Diesel - PCM PIN C1232T - 64</b>
				• Applying vehicle battery voltage to this wire initiates SEIC Stationary Mode process.
				• Signals TorqShift™ transmission to enter SEIC Stationary Mode strategy.
				• Verifies safety enablers.
				• Turns off OBD and other emission-related monitoring.
				• Elevates engine speed to target found at PTO RPM circuit.
Blue/Orange	PTO REQ2	CE933	Input (VPWR)	<b>6.7L Diesel - PCM PIN C1232T - 49</b>
				• Applying vehicle battery voltage to this wire initiates Mobile PTO Mode.
				• Signals TorqShift™ transmission to enter Mobile Mode strategy.
				• Verifies safety enablers.
				• Turns off OBD and other emission-related monitoring.
				• Invokes the PTO relay circuit when safety enablers are met.
Blue/White	PTO RLY	CE326	Output	<b>6.7L Diesel - PCM PIN C1232T - 30</b>
				• A low-side driver, changing from “open-circuit” to “ground” indicating that the engine is ready for the PTO operation to begin and that a PTO load may be applied.
Green	PTO RPM	CE914	Input (Resistor)	• Intended for powering a PTO indicator lamp, or turn on a relay coil (not to exceed 1A). LED lights require adding a resistor in series.
				<b>6.7L Diesel - PCM PIN C1232T - 84</b>
				• Requires the addition of a resistor or potentiometer for any SEIC/PTO mode.
				• Resistor/potentiometer selection determines the fixed or variable engine target speed.
White/Brown	PTO REF	LE434	Reference Voltage	• Combine in circuit with PTO VREF and PTO GND.
				• Speed range available: 900 RPM to 3000 RPM (700 minimum RPM for *Split Shaft operation).
Gray/Red	PTO RTN	RE327	PCM Ground	<b>6.7L Diesel - PCM PIN C1232T - 83</b>
				• A 5VDC reference, buffered against shorts to ground or power, used to complete the resistor circuit for engine speed selection.
Violet/Brown	BCP SW	CE926	Input (VPWR)	<b>6.7L Diesel - PCM PIN C1232T - 85</b>
				• A ground reference, buffered, used to complete the resistor circuit for engine speed selection.
Brown	BCP LP	CE140	Output	<b>6.7L Diesel - PCM PIN C1232T - 19</b>
				• Applying vehicle battery voltage to this wire begins BCP.
				• BCP regulates engine speed between 600 to 1200 RPM to maintain required charge system voltage.
Brown	BCP LP	CE140	Output	<b>6.7L Diesel - PCM PIN C1232T - 75</b>
				• A low-side driver, changing from “open-circuit” to “ground” indicating that BCP is in effect.
				• Intended for powering an indicator lamp.

\*We presently do not offer a Split Shaft option for this platform. Please reference Ford's Body Builder website for additional Split Shaft information.

**Please reference the most current edition of Ford's Body Builder Layout Book for Medium Duty F-Series at [www.fordbbas.com](http://www.fordbbas.com)**

**Offer of Sale**



**WARNING:** This product can expose you to chemicals including Lead and Lead Compounds, and Di(2-ethylhexyl)phthalate (DEHP) which are known to the State of California to cause cancer and birth defects or other reproductive harm. For more information go to [www.P65Warnings.ca.gov](http://www.P65Warnings.ca.gov)

**1. Definitions.** As used herein, the following terms have the meanings indicated.

**Buyer:** means any customer receiving a Quote for Products.

**Buyer's Property:** means any tools, patterns, plans, drawings, designs, specifications materials, equipment, or information furnished by Buyer, or which are or become Buyer's property.

**Confidential Information:** means any technical, commercial, or other proprietary information of Seller, including, without limitation, pricing, technical drawings or prints and/or part lists, which has been or will be disclosed, delivered, or made available, whether directly or indirectly, to Buyer.

**Goods:** means any tangible part, system or component to be supplied by Seller.

**Intellectual Property Rights:** means any patents, trademarks, copyrights, trade dress, trade secrets or similar rights.

**Products:** means the Goods, Services and/or Software as described in a Quote.

**Quote:** means the offer or proposal made by Seller to Buyer for the supply of Products.

**Seller:** means Parker-Hannifin Corporation, all divisions, subsidiaries and businesses selling products under these terms.

**Seller's IP:** means patents, trademarks, copyrights, or other intellectual property rights relating to the Products, including without limitation, names, designs, images, drawings, models, software, templates, information, any improvements or creations or other intellectual property developed prior to or during the relationship contemplated herein.

**Services:** means any services to be provided by Seller.

**Software:** means any software related to the Goods, whether embedded or separately downloaded.

**Special Tooling:** means equipment acquired by Seller or otherwise owned by Seller necessary to manufacture Goods, including but not limited to tools, jigs, and fixtures.

**Terms:** means the terms and conditions of this Offer of Sale.

**2. Terms.** All sales of Products by Seller will be governed by, and are expressly conditioned upon Buyer's assent to, these Terms. These Terms are incorporated into any Quote provided by Seller to Buyer. Buyer's order for any Products whether communicated to Seller verbally, in writing, by electronic data interface or other electronic commerce, shall constitute acceptance of these Terms. Seller objects to any contrary or additional terms or conditions of Buyer. Reference in Seller's order acknowledgement to Buyer's purchase order or purchase order number shall in no way constitute an acceptance of any of Buyer's terms or conditions of purchase. Any Quote made by Seller to Buyer shall be considered a firm and definite offer and shall not be deemed to be otherwise despite any language on the face of the Quote. Seller reserves all rights to accept or reject any purported acceptance by Buyer to Seller's Quote if such purported acceptance attempts to vary the terms of the Quote. If Seller ships Products after Buyer issues an acceptance to the Quote, any additional or different terms proposed by Buyer will not become part of the parties' business relationship unless agreed to in a writing that is signed by an authorized representative of Seller, excluding email correspondence. If the transaction proceeds without such agreement on the part of Seller, the business relationship will be

governed solely by these Terms and the specific terms in Seller's Quote.

**3. Price; Payment.** The Products set forth in the Quote are offered for sale at the prices indicated in the Quote. Unless otherwise specifically stated in the Quote, prices are valid for thirty (30) days and do not include any sales, use, or other taxes or duties. Seller reserves the right to modify prices for any reason and at any time by giving ten (10) days prior written notice. Unless otherwise specified by Seller, all prices are F.C.A. Seller's facility (INCOTERMS 2020). All sales are contingent upon credit approval and full payment for all purchases is due thirty (30) days from the date of invoice (or such date as may be specified in the Quote). Under any circumstances, Buyer may not withhold or suspend payment of any amounts due and payable as a deduction, set-off or recoupment of any amount, claim or dispute with Seller. Unpaid invoices beyond the specified payment date incur interest at the rate of 1.5% per month or the maximum allowable rate under applicable law. Seller reserves the right to require advance payment or provision of securities for first and subsequent deliveries if there is any doubt, in Seller's sole determination, regarding the Buyer's creditworthiness or for other business reasons. If the requested advance payment or securities are not provided to Seller's satisfaction, Seller reserves the right to suspend performance or reject the purchase order, in whole or in part, without prejudice to Seller's other rights or remedies, including the right to full compensation. Seller may revoke or shorten any payment periods previously granted in Seller's sole determination. The rights and remedies herein reserved to Seller are cumulative and in addition to any other or further rights and remedies available at law or in equity. No waiver by Seller of any breach by Buyer of any provision of these terms will constitute a waiver by Seller of any other breach of such provision.

**4. Shipment; Delivery; Title and Risk of Loss.** All delivery dates are approximate, and Seller is not responsible for damages or additional costs resulting from any delay. All deliveries are subject to our ability to procure materials from our suppliers. Regardless of the manner of shipment, delivery occurs and title and risk of loss or damage pass to Buyer, upon placement of the Products with the carrier at Seller's facility. Unless otherwise agreed prior to shipment and for domestic delivery locations only, Seller will select and arrange, at Buyer's sole expense, the carrier and means of delivery. When Seller selects and arranges the carrier and means of delivery, freight and insurance costs for shipment to the designated delivery location will be prepaid by Seller and added as a separate line item to the invoice. Buyer shall be responsible for any additional shipping charges incurred by Seller due to Buyer's acts or omissions. Buyer shall not return or repackage any Products without the prior written authorization from Seller, and any return shall be at the sole cost and expense of Buyer.

**5. Warranty.** The warranty for the Products is as follows: (i) Seller warrants that all products sold conform to the applicable Parker Chelsea standard specification for the lesser period of 2 years (24 Months) from date of service or 2-1/2 years (30 Months) from date of build (as marked on the product name plate; (ii) Services shall be performed in accordance with generally accepted practices and using the degree of care and skill that is ordinarily exercised and customary in the field to which the Services pertain and are warranted for a period of six (6) months from the date of completion of the Services; and (iii) Software is only warranted to perform in accordance with applicable specifications provided by Seller to Buyer for ninety (90) days from the date of delivery or, when downloaded by a Buyer or end-user, from the date of the initial download. All prices are based upon the exclusive limited warranty stated above, and upon the following disclaimer: **EXEMPTION CLAUSE; DISCLAIMER OF WARRANTY, CONDITIONS, REPRESENTATIONS: THIS WARRANTY IS THE SOLE AND ENTIRE WARRANTY, CONDITION, AND**

Continued on Next Page

**Offer of Sale (Continued)**

**REPRESENTATION, PERTAINING TO PRODUCTS. SELLER DISCLAIMS ALL OTHER WARRANTIES, CONDITIONS, AND REPRESENTATIONS, WHETHER STATUTORY, EXPRESS OR IMPLIED, INCLUDING BUT NOT LIMITED TO THOSE RELATING TO DESIGN, NONINFRINGEMENT, MERCHANTABILITY, AND FITNESS FOR A PARTICULAR PURPOSE. SELLER DOES NOT WARRANT THAT THE SOFTWARE IS ERROR-FREE OR FAULT-TOLERANT, OR THAT BUYER'S USE THEREOF WILL BE SECURE OR UNINTERRUPTED, UNLESS OTHERWISE AUTHORIZED IN WRITING BY SELLER, THE SOFTWARE SHALL NOT BE USED IN CONNECTION WITH HAZARDOUS OR HIGH-RISK ACTIVITIES OR ENVIRONMENTS. EXCEPT AS EXPRESSLY STATED HEREIN, ALL PRODUCTS ARE PROVIDED "AS IS".**

**6. Claims; Commencement of Actions.** Buyer shall promptly inspect all Products upon receipt. No claims for shortages will be allowed unless reported to Seller within ten (10) days of delivery. Buyer shall notify Seller of any alleged breach of warranty within thirty (30) days after the date the non-conformance is or should have been discovered by Buyer. Any claim or action against Seller based upon breach of contract or any other theory, including tort, negligence, or otherwise must be commenced within twelve (12) months from the date of the alleged breach or other alleged event, without regard to the date of discovery.

**7. LIMITATION OF LIABILITY. IN THE EVENT OF A BREACH OF WARRANTY, SELLER WILL, AT ITS OPTION, REPAIR OR REPLACE THE NON-CONFORMING PRODUCTS, RE-PERFORM THE SERVICES, OR REFUND THE PURCHASE PRICE PAID WITHIN A REASONABLE PERIOD OF TIME. IN NO EVENT IS SELLER LIABLE FOR ANY SPECIAL, INDIRECT, INCIDENTAL OR CONSEQUENTIAL DAMAGES INCLUDING ANY LOSS OF REVENUE OR PROFITS, WHETHER BASED IN CONTRACT, TORT OR OTHER LEGAL THEORY. IN NO EVENT SHALL SELLER'S LIABILITY UNDER ANY CLAIM MADE BY BUYER EXCEED THE PURCHASE PRICE PAID FOR THE PRODUCTS.**

**8. Confidential Information.** Buyer acknowledges and agrees that Confidential Information has been and will be received in confidence and will remain the property of Seller. Buyer further agrees that it will not use Seller's Confidential Information for any purpose other than for the benefit of Seller and shall return all such Confidential Information to Seller within thirty (30) days upon request.

**9. Loss to Buyer's Property.** Buyer's Property will be considered obsolete and may be destroyed by Seller after two (2) consecutive years have elapsed without Buyer ordering the Products manufactured using Buyer's Property. Also, Seller shall not be responsible for any loss or damage to Buyer's Property while it is in Seller's possession or control.

**10. Special Tooling.** Seller may impose a tooling charge for any Special Tooling. Special Tooling shall be and remain Seller's property. In no event will Buyer acquire any interest in the Special Tooling, even if such Special Tooling has been specially converted or adapted for manufacture of Goods for Buyer and notwithstanding any charges paid by Buyer. Unless otherwise agreed, Seller has the right to alter, discard or otherwise dispose of any Special Tooling or other property owned by Seller in its sole determination at any time.

**11. Security Interest.** To secure payment of all sums due from Buyer, Seller retains a security interest in all Products delivered to Buyer and, Buyer's acceptance of these Terms is deemed to be a Security Agreement under the Uniform Commercial Code. Buyer authorizes Seller as its attorney to execute and file on Buyer's behalf all documents Seller deems necessary to perfect Seller's security interest.

**12. User Responsibility.** Buyer, through its own analysis and testing, is solely responsible for making the final selection of the Products and assuring that all performance, endurance, maintenance, safety and warning requirements of the application of the Products are met. Buyer must analyze all aspects of

the application and follow applicable industry standards, specifications, and any technical information provided with the Quote or the Products, such as Seller's instructions, guides and specifications. If Seller provides options of or for Products based upon data or specifications provided by Buyer, Buyer is responsible for determining that such data and specifications are suitable and sufficient for all applications and reasonably foreseeable uses of the Products. In the event Buyer is not the end-user of the Products, Buyer will ensure such end-user complies with this paragraph.

**13. Use of Products, Indemnity by Buyer.** Buyer shall comply with all instructions, guides and specifications provided by Seller with the Quote or the Products. If Buyer uses or resells the Products in any way prohibited by Seller's instructions, guides or specifications, or Buyer otherwise fails to comply with Seller's instructions, guides and specifications, Buyer acknowledges that any such use, resale, or non-compliance is at Buyer's sole risk. Further, Buyer shall indemnify, defend, and hold Seller harmless from any losses, claims, liabilities, damages, lawsuits, judgments and costs (including attorney fees and defense costs), whether for personal injury, property damage, intellectual property infringement or any other claim, arising out of or in connection with: (a) improper selection, design, specification, application, or any misuse of Products; (b) any act or omission, negligent or otherwise, of Buyer; (c) Seller's use of Buyer's Property; (d) damage to the Products from an external cause, repair or attempted repair by anyone other than Seller, failure to follow instructions, guides and specifications provided by Seller, use with goods not provided by Seller, or opening, modifying, deconstructing, tampering with or repackaging the Products; or (e) Buyer's failure to comply with these Terms, including any legal or administrative proceedings, collection efforts, or other actions arising from or relating to such failure to comply. Seller shall not indemnify Buyer under any circumstance except as otherwise provided in these Terms.

**14. Cancellations and Changes.** Buyer may not cancel or modify, including but not limited to movement of delivery dates for the Products, any order for any reason except with Seller's written consent and upon terms that will indemnify, defend and hold Seller harmless against all direct, incidental and consequential loss or damage and any additional expense. Seller, at any time, may change features, specifications, designs and availability of Products.

**15. Assignment.** Buyer may not assign its rights or obligations without the prior written consent of Seller.

**16. Force Majeure.** Seller is not liable for delay or failure to perform any of its obligations by reason of any events or circumstances beyond its reasonable control. Such circumstances include without limitation: accidents, labor disputes or stoppages, government acts or orders, acts of nature, pandemics, epidemics, other widespread illness, or public health emergency, cyber related disruptions, cyber-attacks, ransomware sabotage, delays or failures in delivery from carriers or suppliers, shortages of materials, sudden increases in the price of raw material or components, shutdowns or slowdowns affecting the supply of raw materials or components, or the transportation thereof, oil shortages or oil price increases, energy crisis, energy or fuel interruption, war (whether declared or not) or the serious threat of same, riots, rebellions, acts of terrorism, embargoes, fire or any reason whether similar to the foregoing or otherwise. Seller will resume performance as soon as practicable after the event of force majeure has been removed. All delivery dates affected by an event of force majeure shall be tolled for the duration of such event of force majeure and rescheduled for mutually agreed dates as soon as practicable after the event of force majeure ceases to exist. The right to allocate capacity is in the Seller's sole discretion. An event of force majeure shall not include financial distress, insolvency, bankruptcy, or other similar conditions affecting one of the parties, affiliates and/or subcontractors. An event of force majeure in the meaning of

Continued on Next Page

**Offer of Sale (Continued)**

**WARNING:** This product can expose you to chemicals including Lead and Lead Compounds, and Di(2-ethylhexyl)phthalate (DEHP) which are known to the State of California to cause cancer and birth defects or other reproductive harm. For more information go to [www.P65Warnings.ca.gov](http://www.P65Warnings.ca.gov)

these Terms means any circumstances beyond Seller's control that permanently or temporarily hinders performance, even where that circumstance was already foreseen. Buyer shall not be entitled to cancel any orders following its claim of an event of force majeure.

**17. Waiver and Severability.** Failure to enforce any provision of these Terms will not invalidate that provision; nor will any such failure prejudice either party's right to enforce that provision in the future. Invalidation of any provision of these Terms shall not invalidate any other provision herein and, the remaining provisions will remain in full force and effect.

**18. Duration.** Unless otherwise stated in the Quote, any agreement governed by or arising from these Terms shall: (a) be for an initial duration of one (1) year; and (b) shall automatically renew for successive one-year terms unless terminated by Buyer with at least 180-days written notice to Seller or if Seller terminates the agreement pursuant to Section 19 of these Terms.

**19. Termination.** Seller may, without liability to Buyer, terminate any agreement governed by or arising from these Terms for any reason and at any time by giving Buyer thirty (30) days prior written notice. Seller may immediately terminate, in writing, if Buyer: (a) breaches any provision of these Terms, (b) becomes or is deemed insolvent, (c) appoints or has appointed a trustee, receiver or custodian for all or any part of Buyer's property, (d) files a petition for relief in bankruptcy on its own behalf, or one is filed against Buyer by a third party, (e) makes an assignment for the benefit of creditors; or (f) dissolves its business or liquidates all or a majority of its assets.

**20. Ownership of Rights.** Buyer agrees that (a) Seller (and/or its affiliates) owns or is the valid licensee of Seller's IP and (b) the furnishing of information, related documents or other materials by Seller to Buyer does not grant or transfer any ownership interest or license in or to Seller's IP to Buyer, unless expressly agreed in writing. Without limiting the foregoing, Seller retains ownership of all Software supplied to Buyer. In no event shall Buyer obtain any greater right in and to the Software than a right in a license limited to the use thereof and subject to compliance with any other terms provided with the Software. Buyer further agrees that it will not, directly or through intermediaries, reverse engineer, decompile, or disassemble any Software (including firmware) comprising or contained within a Product, except and only to the extent that such activity may be expressly permitted, either by applicable law or, in the case of open-source software, the applicable open-source license.

**21. Indemnity for Infringement of Intellectual Property Rights.** Seller is not liable for infringement of any Intellectual Property Rights except as provided in this Section. Seller will defend at its expense and will pay the cost of any settlement or damages awarded in an action brought against Buyer based on a third-party claim that one or more of the Products infringes the Intellectual Property Rights of a third party in the country of delivery of the Products by Seller to Buyer. Seller's obligation to defend and indemnify Buyer is contingent on Buyer notifying Seller within ten (10) days after Buyer becomes aware of any such claim, and Seller having sole control over the defense of the claim including all negotiations for settlement or compromise. If one or more Products is subject to such a claim, Seller may, at its sole expense and option, procure for Buyer the right to continue using the Products, replace or modify the Products to render them non-infringing, or offer to accept return of the Products and refund the purchase price less a reasonable allowance for depreciation. Seller has no obligation or liability for any claim of infringement: (i) arising from information provided by Buyer (including Seller's use of Buyer's Property); or (ii) directed to any Products for which the designs are specified in whole or part by Buyer; or (iii) resulting from the modification, combination or use in a system of any Products. The foregoing provisions of this Section constitute Seller's sole and exclusive liability and Buyer's sole and exclusive remedy for claims of infringement of Intellectual Property Rights.

**22. Governing Law.** These Terms, the terms of any Quote, and the sale and delivery of all Products are deemed to have taken

place in, and shall be governed and construed in accordance with, the laws of the State of Ohio, as applicable to contracts executed and wholly performed therein and without regard to conflicts of laws principles. Buyer irrevocably agrees and consents to the exclusive jurisdiction and venue of the courts of Cuyahoga County, Ohio with respect to any dispute, controversy or claim arising out of or relating to the sale and delivery of the Products.

**23. Entire Agreement.** These Terms, along with the terms set forth in the Quote, forms the entire agreement between the Buyer and Seller and constitutes the final, complete and exclusive expression of the terms of sale and purchase. In the event of a conflict between any term set forth in the Quote and these Terms, the terms set forth in the Quote shall prevail. All prior or contemporaneous written or oral agreements or negotiations with respect to the subject matter shall have no effect. No modification to these Terms will be binding on Seller unless agreed to in a writing that is signed by an authorized representative of Seller, excluding email correspondence, 'clickwrap' or other purported electronic assent to different or additional terms. Sections 2-25 of these Terms shall survive termination or cancellation of any agreement governed by or arising from these Terms.

**24. No 'Wrap' Agreements/No Authority to Bind.** Seller's clicking any buttons or any similar action, such as clicking "I Agree" or "Confirm," to utilize Buyer's software or webpage for the placement of orders, is NOT an agreement to Buyer's Terms and Conditions. **NO EMPLOYEE, AGENT OR REPRESENTATIVE OF SELLER HAS THE AUTHORITY TO BIND SELLER BY THE ACT OF CLICKING ANY BUTTON OR SIMILAR ACTION ON BUYER'S WEBSITE OR PORTAL.**

**25. Compliance with Laws.** Buyer agrees to comply with all applicable laws, regulations, and industry and professional standards, including those of the United States of America, and the country or countries in which Buyer may operate, including without limitation the U.S. Foreign Corrupt Practices Act ("FCPA"), the U.S. Anti-Kickback Act ("Anti-Kickback Act"), U.S. and E.U. export control and sanctions laws ("Export Laws"), the U.S. Food Drug and Cosmetic Act ("FDCA"), and the rules and regulations promulgated by the U.S. Food and Drug Administration ("FDA"), each as currently amended. Buyer agrees to indemnify, defend, and hold harmless Seller from the consequences of any violation of such laws, regulations and standards by Buyer, its employees or agents. Buyer represents that it is familiar with all applicable provisions of the FCPA, the Anti-Kickback Act, Export Laws, the FDCA and the FDA and certifies that Buyer will adhere to the requirements thereof and not take any action that would make Seller violate such requirements. Buyer represents and agrees that Buyer will not make any payment or give anything of value, directly or indirectly, to any governmental official, foreign political party or official thereof, candidate for foreign political office, or commercial entity or person, for any improper purpose, including the purpose of influencing such person to purchase Products or otherwise benefit the business of Seller. Buyer further represents and agrees that it will not receive, use, service, transfer or ship any Products from Seller in a manner or for a purpose that violates Export Laws or would cause Seller to be in violation of Export Laws. Buyer agrees to promptly and reliably provide Seller all requested information or documents, including end-user statements and other written assurances, concerning Buyer's ongoing compliance with Export Law.

09/22

# Parker Worldwide

## Europe, Middle East, Africa

**AE – United Arab Emirates,**  
Dubai

Tel: +971 4 8127100  
parker.me@parker.com

**AT – Austria,** Wiener Neustadt

Tel: +43 (0)2622 23501-0  
parker.austria@parker.com

**AT – Eastern Europe,** Wiener  
Neustadt

Tel: +43 (0)2622 23501 900  
parker.easteurope@parker.com

**AZ – Azerbaijan,** Baku

Tel: +994 50 22 33 458  
parker.azerbaijan@parker.com

**BE/LU – Belgium,** Nivelles

Tel: +32 (0)67 280 900  
parker.belgium@parker.com

**BG – Bulgaria,** Sofia

Tel: +359 2 980 1344  
parker.bulgaria@parker.com

**BY – Belarus,** Minsk

Tel: +375 17 209 9399  
parker.belarus@parker.com

**CH – Switzerland,** Etoy

Tel: +41 (0)21 821 87 00  
parker.switzerland@parker.com

**CZ – Czech Republic,** Klecany

Tel: +420 284 083 111  
parker.czechrepublic@parker.com

**DE – Germany,** Kaarst

Tel: +49 (0)2131 4016 0  
parker.germany@parker.com

**DK – Denmark,** Ballerup

Tel: +45 43 56 04 00  
parker.denmark@parker.com

**ES – Spain,** Madrid

Tel: +34 902 330 001  
parker.spain@parker.com

**FI – Finland,** Vantaa

Tel: +358 (0)20 753 2500  
parker.finland@parker.com

**FR – France,** Contamine s/Arve

Tel: +33 (0)4 50 25 80 25  
parker.france@parker.com

**GR – Greece,** Athens

Tel: +30 210 933 6450  
parker.greece@parker.com

**HU – Hungary,** Budaoers

Tel: +36 23 885 470  
parker.hungary@parker.com

**IE – Ireland,** Dublin

Tel: +353 (0)1 466 6370  
parker.ireland@parker.com

**IT – Italy,** Corisico (MI)

Tel: +39 02 45 19 21  
parker.italy@parker.com

**KZ – Kazakhstan,** Almaty

Tel: +7 7273 561 000  
parker.easteurope@parker.com

**NL – The Netherlands,** Oldenzaal

Tel: +31 (0)541 585 000  
parker.nl@parker.com

**NO – Norway,** Asker

Tel: +47 66 75 34 00  
parker.norway@parker.com

**PL – Poland,** Warsaw

Tel: +48 (0)22 573 24 00  
parker.poland@parker.com

**PT – Portugal,** Leca de Palmeira

Tel: +351 22 999 7360  
parker.portugal@parker.com

**RO – Romania,** Bucharest

Tel: +40 21 252 1382  
parker.romania@parker.com

**RU – Russia,** Moscow

Tel: +7 495 645-2156  
parker.russia@parker.com

**SE – Sweden,** Spånga

Tel: +46 (0)8 59 79 50 00  
parker.sweden@parker.com

**SK – Slovakia,** Banská Bystrica

Tel: +421 484 162 252  
parker.slovakia@parker.com

**SL – Slovenia,** Novo Mesto

Tel: +386 7 337 6650  
parker.slovenia@parker.com

**TR – Turkey,** Istanbul

Tel: +90 216 4997081  
parker.turkey@parker.com

**UA – Ukraine,** Kiev

Tel: +380 44 494 2731  
parker.ukraine@parker.com

**UK – United Kingdom,** Warwick

Tel: +44 (0)1926 317 878  
parker.uk@parker.com

**ZA – South Africa,** Kempton Park

Tel: +27 (0)11 961 0700  
parker.southafrica@parker.com

## North America

**CA – Canada,** Milton, Ontario

Tel: +1 905 693 3000

**MX – Mexico,** Toluca

Tel: +52 72 2275 4200

## Asia Pacific

**AU – Australia,** Castle Hill

Tel: +61 (0)2-9634 7777

**CN – China,** Shanghai

Tel: +86 21 2899 5000

**HK – Hong Kong**

Tel: +852 2428 8008

**IN – India,** Mumbai

Tel: +91 22 6513 7081-85

**JP – Japan,** Fujisawa

Tel: +81 (0)4 6635 3050

**KR – South Korea,** Seoul

Tel: +82 2 559 0400

**MY – Malaysia,** Shah Alam

Tel: +60 3 7849 0800

**NZ – New Zealand,** Mt Wellington

Tel: +64 9 574 1744

**SG – Singapore**

Tel: +65 6887 6300

**TH – Thailand,** Bangkok

Tel: +662 717 8140

**TW – Taiwan,** New Taipei City

Tel: +886 2 2298 8987

## South America

**AR – Argentina,** Buenos Aires

Tel: +54 3327 44 4129

**BR – Brazil,** Cachoeirinha RS

Tel: +55 51 3470 9144

**CL – Chile,** Santiago

Tel: +56 2 623 1216

**Pan Am,** Miami

Tel: +1 305-470-8800

### Parker-Hannifin Corporation

Chelsea Products Division  
8225 Hacks Cross Rd  
Olive Branch, MS 38654  
United States

Phone: +1 (662) 895-1011

Email: chd\_support@support.parker.com

www.Parker.com/Chelsea

PN: HY25-1400-M1/US

Rev: 06/24

