

A M E R I C A N W E T T A N K S Y S T E M S

AMERICAN

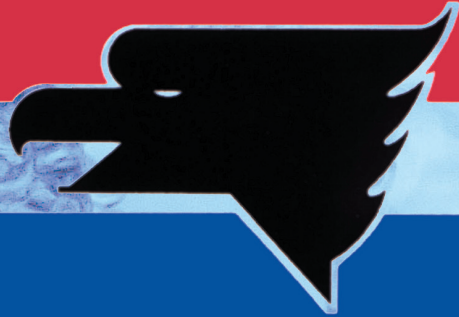

MOBILE POWER

get the

WET TANK

SOLUTION



1-800-634-8265

www.americanmobilepower.com

Vol. 9



American....
your “just in time”
supplier



American Distributor Program

Wet Tank Systems

American has developed a line of “Hydraulic Wet Tank Systems” tailored to “Just-In-Time” delivery to meet your requirements. Standard systems range from 7 to 100 gallon capacities utilizing Polyethylene, Steel, and Aluminum materials. American’s standard tank systems have been designed and packaged for rapid shipment via UPS.

Multiple Tank Shipments

The American Program provides UPS or truck freight shipment of units where and when required. Your purchase order can direct single or multiple shipments to any branch location with central or branch billing. Multiple unit orders can be “split”, with partial shipment to a branch or drop shipped to your customer.

Custom Tank Design

American features tank systems from 7-110 gallon capacity. Custom built tanks are available utilizing our basic steel or aluminum designs. These units can be ported, vented, and finished to your applicable specifications. Our plant provides rapid “turn-around” and competitive pricing on custom units. Call today for more information on Custom units!

Ordering Information

1-800-634-8265

Street Address

American Mobile Power
619 E. Jefferson Street
Fairmount, IN 46928

Mailing/Remit To

American Mobile Power
P.O. Box 68
Fairmount, IN 46928

Terms

Open Account terms are 2%-10 days, Net 30 days.
2% discount is on standard tanks only!
1-1/2% per month on outstanding balance until paid in full.
F.O.B. our plant facility
VISA/MasterCard Accepted
NOTE: Unless credit has been established with our company,
shipment will be C.O.D. or Credit Card.

Returns

Returns will not be accepted without a returned goods authorization number (RGA#).
Restocking charges will apply to returned merchandise.

24-Hour Fax Line

(765) 948-3403

E-Mail

sales@americanmobilepower.com

Warranties

All products guaranteed to be free from defective material and workmanship
for a period of one year from manufacture date. Liability limited to replacement
of defective parts. See next page...

Literature

Care has been taken in preparation of this literature. American Mobile Power
is not responsible for errors or omissions.

Serial Numbers

All tank assemblies carry an identification plate or serial number imprinted
in the tank body.



WARRANTY

The American Wet Tank System is warranted to be free of defects in material or workmanship and to meet American Mobile Power's written specifications at the time of sale. American's obligation and liability under this warranty is expressly limited to repairing or replacing, at American's option, within one year after date of original installation any defective part or parts or any product not meeting the specifications.

This warranty is in lieu of all other warranties, express or implied. American makes no warranty of merchant ability or of fitness for any particular purpose. American's obligation under this warranty shall not include any transportation charges or costs of installation of any liability for direct, indirect, special, incidental, or consequential damages or delay. The remedies set forth herein are exclusive, and American's liability with respect to any contract or sale or anything done in connection therewith, whether in contract, in tort, under any warranty, or otherwise, shall not, except as expressly provided herein, exceed the price of the product or part on which such liability is based.

If requested by American, products or parts for which a warranty claim is made are to be returned transportation prepaid to a Service Center designated by American. Any installation or use not in accordance with the catalog or package instructions, other improper use, operation beyond an intermittent duty, substitution of parts not approved by American, use with equipment other than the equipment on which the Wet Tank System is first installed, or alteration or repair made to the unit other than at an American designated Service Facility, shall void this warranty.



WARNING:

IMPROPER SELECTION OR IMPROPER USE OF THE PRODUCTS AND/OR SYSTEMS DESCRIBED HEREIN OR RELATED ITEMS CAN CAUSE DEATH, PERSONAL INJURY AND PROPERTY DAMAGE.

This document and other information from American Mobile Power and authorized distributors provide this product and/or system options for further investigation by users having technical expertise. It is important that you analyze all aspects of your application and review the information concerning the product or system in the current product catalog. Due to the variety of operating conditions and applications for these products or systems, the user, through its own analysis and testing, is solely responsible for making the final selection of the products and systems and assuring that all performance, safety and warning requirements of the application are met. The products described herein, including without limitation, product features and specifications. Designs are subject to change by American Mobile Power at any time without notice.

Table of Contents

Hydraulic Systems

Hydraulic Tanks	
Uprights.....	4-11
Saddlemounts	12-23
Sidemounts.....	24-30
Specialty.....	31-33
Hydraulic Mounting Products	
Mounting Kits	34-36
Mounting Kit Parts	37
Fill Assembly Products	
Fill Assemblies.....	38
Fill Assembly Parts	39
Hydraulic Tank Parts	
Hydraulic Parts	40
Hydraulic Hose Kits & Parts	
3 line Hose Kit System.....	42
2 line Hose Kit System.....	43
Hose Support Kits	44
Parts.....	45

Transfer Systems

Transfer Tanks	
Uprights.....	46-47
Deckmounts	48-49
“L” Styles	50-52
Transfer Pumps	53
Transfer Parts	54

Reefer Systems

Reefer Tanks	
22” Reefers.....	55
24” Reefers.....	56
Reefer Mounting Products	
Mounting Kits	57-58
Reefer Parts	59

Installation

Installation Guides	60-70
----------------------------------	-------



Model A2000

Polyethylene Upright - 50 Gallon

Tank Size: 36" long x 16" wide x 26" high

Shipping Weight: 80#

Polyethylene tank assembly with two 2" screw-in NPT bottom ports; filler/breather assembly - including 40 micron filter/breather cap (chain mounted); heavy duty mounting base; one 2" to 1 1/4" plated reducer bushing; the ASK-200 mounting and spring kit. This unit may be used for a two or three line system. Base and fill assembly are factory installed and mounted. Diffuser, fill cap, reducer bushing and mounting kit are boxed individually. All shipped in one carton. Oil and temperature level indicator included.

CHANGES MAY BE MADE TO PRODUCT WITHOUT NOTICE.

TO SEE OUR FULL LINE OF DRAWINGS GO TO WWW.AMERICANMOBILEPOWER.COM

Order No.	Weight	Description	Page #
ASK-200	12#	Chassis Mounting Kit	37
APP-225	1#	Port Reducer Bushing - plated, 2" x 1-1/4"	41
ADA-250	2#	Diffuser Assembly - 8" long - 2" to 1-1/4"	40
ABC-315	1#	Filter/Breather Cap Only	39
AFC-330	2#	Fill Assembly	38
AMB-312	20#	Mounting Base Panel	37

ALL TANKS FACTORY TESTED

Model A3000

Steel Upright - 50 Gallon

Tank Size: 34" long x 13" wide x 26" high

Shipping Weight: 150#



Steel tank assembly with diamond plate top section; fully baffled; two 1-1/4" NPT bottom ports, internally diffused; dual mounting rails (2"x 2") welded to tank assembly. Tank is powder coated black. Features filtered mushroom vent in tank top for increased air exchange. Filler/Breather assembly - including 40 micron filter/breather cap (chain-mounted) with nylon strainer basket and bayonet closure. The ASK-200 mounting and spring kit includes four pre-drilled powder coated mounting angles, plated bolts, washers, lock nuts, four plated springs, and four pre-drilled mounting pads. The mounting kit is boxed and shipped in the tank assembly carton. The complete unit is packaged in a single carton and shipped by UPS.

Ordering Options

<i>Product</i>	<i>Product Description</i>
A3000	1-1/4" NPT bottom ports
A3000-ST	1-1/4" NPT bottom ports & Sight Temperature Gauge
A3000-15	1-1/2" NPT bottom ports
A3000-15ST	1-1/2" NPT bottom ports & Sight Temperature Gauge
* A3000-2	2" NPT bottom ports
* A3000-2ST	2" NPT bottom ports & Sight Temperature Gauge

*2" Ports are non-diffused

**CHANGES MAY BE MADE TO PRODUCT WITHOUT NOTICE.
TO SEE OUR FULL LINE OF DRAWINGS GO TO WWW.AMERICANMOBILEPOWER.COM**

Order No.	Weight	Description	Page #
ABA-138	1#	Breather Vent - 3/8" NPT	39
ASK-200	12#	Chassis Mounting Kit	37
ABC-315	1#	Filter/Breather Cap Only	39
AFC-330	2#	Fill Assembly	38



Model A3035-ST

Steel Upright - 35 Gallon

Tank Size: 42" long x 8" wide x 24" high

Shipping Weight: 120#

Steel tank assembly with diamond plate top section; fully baffled. Two 1-1/4" NPT bottom ports, internally diffused; dual mounting rails (2" x 2") welded to tank assembly. Tank is powder coated black. Filter/breather assembly-including 40 micron filter/breather cap (chain mounted) with nylon strainer basket and bayonet closure. The ASK-200 mounting and spring kit includes four pre-drilled powder coated mounting angles, plated bolts, washers, lock nuts, four plated springs, and four pre-drilled mounting pads. The mounting kit is boxed and shipped in the tank assembly carton. Oil and temperature level indicator is included. The complete unit is packaged in one carton and shipped by UPS.

CHANGES MAY BE MADE TO PRODUCT WITHOUT NOTICE.

TO SEE OUR FULL LINE OF DRAWINGS GO TO WWW.AMERICANMOBILEPOWER.COM

Order No.	Weight	Description	Page #
ASK-200	12#	Chassis Mounting Kit	37
ABC-315	1#	Filter/Breather Cap Only	39
AFC-330	2#	Fill Assembly	38

ALL TANKS FACTORY TESTED

Model A3070

Steel Upright - 70 Gallon

Tank Size: 46.5" long x 13" wide x 26" high
 Shipping Weight: 135#
 Mounting Kit Weight: 52#



Total steel construction; top tank section built of Diamond Plate; fully baffled. Two 1-1/2" NPT bottom ports, internally diffused. Tank assembly powder coated black. Features filtered mushroom vent in tank top for increased air exchange. Filler/breather assembly - including 40 micron filter/breather cap (chain mounted) with nylon strainer basket and bayonet closure. Base assembly carton includes mounting base, carbon steel strap assembly with springs and rubber mounting pads. Mounting kit includes four pre-drilled powder coated mounting angles, plated bolts, washers, nyloc-nuts, four plated springs and four pre-drilled mounting pads. Mounting kit (ASK-200) is boxed and shipped in the base carton. Complete unit is boxed and shipped in two cartons and shipped by UPS.

Ordering Options

Product	Product Description
A3070	1-1/2" NPT bottom ports
A3070-ST	1-1/2" NPT bottom ports & Sight Temperature Gauge
* A3070-2	2" NPT bottom ports
* A3070 -2ST	2" NPT bottom ports & Sight Temperature Gauge

*2" Ports are non-diffused

CHANGES MAY BE MADE TO PRODUCT WITHOUT NOTICE.
TO SEE OUR FULL LINE OF DRAWINGS GO TO WWW.AMERICANMOBILEPOWER.COM

Order No.	Weight	Description	Page #
ABA-138	1#	Breather Vent - 3/8"	39
ASK-200	12#	Chassis Mounting Kit	37
ABC-315	1#	Filter/Breather Cap Only	39
AFC-330	2#	Fill Assembly	38
ABK-340-C	52#	Mounting Base Kit Complete	36
AMT-307	135#	Upright Steel Tank Only	

ALL TANKS FACTORY TESTED

OPTION: Available with stainless steel straps.



Model A30100-ST

Steel Upright - 100 Gallon

Tank Size: 48" long x 16" wide x 30" high

Shipping Weight: 248#



Steel tank assembly, fully baffled. Two 2" NPT bottom ports; one 2" NPT bottom center drain port with plug. Tank assembly is powder coated black. Two filtered mushroom vents in tank top for increased air exchange. Filler/Breather assembly, including 40 micron filter/breather cap (chain mounted) with nylon strainer basket and bayonet closure. Two base angles welded to tank body; four 2.5"x 2.5" x 4" gusseted mounting angles shipped loose. The ASK-210 heavy duty spring mounting kit; fill assembly, port plug and mushroom vents are packaged in a separate carton. Oil and temperature level indicator included. Complete tank assembly and carton are skid mounted for truck freight.

CHANGES MAY BE MADE TO PRODUCT WITHOUT NOTICE.

TO SEE OUR FULL LINE OF DRAWINGS GO TO WWW.AMERICANMOBILEPOWER.COM

Order No.	Weight	Description	Page #
ABA-138	1#	Breather Vent - 3/8" NPT	39
ASK-210	20#	Heavy Duty Chassis Mounting Kit	37
ABC-315	1#	Filter/Breather Cap Only	39
AFC-330	2#	Fill Assembly	38
APP-220	1#	Steel Port Plug - 2" NPT	41
ASG-105	1#	Sight/Temperature Gauge	40
ASK-200G	12#	2.5" x 2.5" x 4" Gusseted Mounting Kit	37

ALL TANKS FACTORY TESTED

Model A4000

Aluminum Upright - 50 Gallon

Tank Size: 34" long x 13" wide x 26" high

Shipping Weight: 77#



Total aluminum construction; top tank section built of Bright Diamond Plate, balance bright mill finish; fully baffled. Two heavy duty machined 1-1/4" NPT bottom ports, internally diffused. Features filtered mushroom vent in tank top for increased air exchange. Filler/Breather assembly - including 40 micron filter/breather cap (chain mounted) with nylon strainer basket and bayonet closure. Dual mounting rails (2" x 2") welded to tank body. Mounting kit includes four pre-drilled powder coated mounting angles, plated bolts, washers, lock-nuts, four plated springs, and four pre-drilled mounting pads. Mounting kit (ASK-200) is boxed and shipped in the tank assembly carton. Complete unit is packaged in one carton and shipped by UPS.

Ordering Options

<i>Product</i>	<i>Product Description</i>
A4000	1-1/4" NPT bottom ports
A4000-ST	1-1/4" NPT bottom ports & Sight Temperature Gauge
A4000-15	1-1/2" NPT bottom ports
A4000-15ST	1-1/2" NPT bottom ports & Sight Temperature Gauge
* A4000-2	2" NPT bottom ports
* A4000-2ST	2" NPT bottom ports & Sight Temperature Gauge

*2" Ports are non-diffused

CHANGES MAY BE MADE TO PRODUCT WITHOUT NOTICE.

TO SEE OUR FULL LINE OF DRAWINGS GO TO WWW.AMERICANMOBILEPOWER.COM

Order No.	Weight	Description	Page #
ABA-16	1#	Breather Vent - 1" NPT	39
ASK-200	12#	Chassis Mounting Kit	37
ABC-315	1#	Filter/Breather Cap Only	39
AFC-330	2#	Fill Assembly	38

ALL TANKS FACTORY TESTED



Model A4035-ST

Aluminum Upright - 35 Gallon

Tank Size: 42" long x 8" wide x 24" high

Shipping Weight: 66#



Total aluminum construction; top tank section built of bright diamond plate, balance bright mill finish; fully baffled. Two heavy duty machined 1-1/4" NPT bottom ports, internally diffused. Filler/breather assembly including 40 micron filter/breather cap (chain mounted) with nylon strainer basket and bayonet closure. Dual mounting rails (2" x 2") welded to tank body. Mounting kit includes four pre-drilled powder coated mounting angles, plated bolts, washers, lock-nuts, four plated springs, and four pre-drilled mounting pads. Mounting kit (ASK-200) is boxed and shipped in the tank assembly carton. Oil and temperature level indicator included. Complete unit is packaged in one carton and shipped by UPS.

CHANGES MAY BE MADE TO PRODUCT WITHOUT NOTICE.

TO SEE OUR FULL LINE OF DRAWINGS GO TO WWW.AMERICANMOBILEPOWER.COM

Order No.	Weight	Description	Page #
ASK-200	12#	Chassis Mounting Kit	37
ABC-315	1#	Filter/Breather Cap Only	39
AFC-330	2#	Fill Assembly	38
ASG-105	1#	Sight/Temperature Gauge	40

ALL TANKS FACTORY TESTED

Model A4070

Aluminum Upright - 70 Gallon

Tank Size: 46.5" long x 13" wide x 26" high

Shipping Weight: 66#

Mounting Kit Weight: 52#

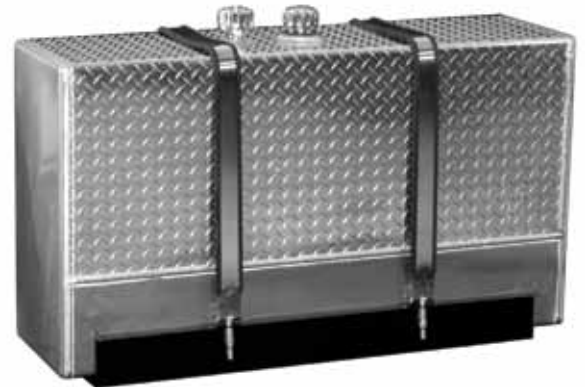

Picture shown with stainless strap option.

Aluminum tank assembly; top tank section built of Bright Diamond Plate, balance bright mill finish; fully baffled. Two heavy duty machined 1-1/2" NPT bottom ports, internally diffused. Features filtered mushroom vent in tank top for increased air exchange. Filler/Breather assembly - including 40 micron filter/breather cap (chain mounted) with nylon strainer basket and bayonet closure. Base assembly carton includes mounting base, carbon steel strap assembly with springs and rubber pads. Mounting kit includes four pre-drilled powder-coated mounting angles, plated bolts, washers, nyloc-nuts, four plated springs and four pre-drilled mounting pads. Mounting kit (ASK-200) is boxed and shipped in the base assembly carton. Complete unit is packaged in two cartons and shipped by UPS.

Ordering Options

Product	Product Description
A4070	1-1/2" NPT bottom ports
A4070-ST	1-1/2" NPT bottom ports & Sight Temperature Gauge
* A4070-2	2" NPT bottom ports
* A4070 -2ST	2" NPT bottom ports & Sight Temperature Gauge

*2" Ports are non-diffused

CHANGES MAY BE MADE TO PRODUCT WITHOUT NOTICE.

TO SEE OUR FULL LINE OF DRAWINGS GO TO WWW.AMERICANMOBILEPOWER.COM

Order No.	Weight	Description	Page #
ABA-16	1#	Breather Vent - 1" NPT	39
ASK-200	12#	Chassis Mounting Kit	37
ABC-315	1#	Filter/Breather Cap Only	39
AFC-330	2#	Fill Assembly	38
ABK-340-C	52#	Mounting Base Kit Complete	36
AMT-407	66#	Upright Aluminum Tank Only	

ALL TANKS FACTORY TESTED

OPTION: Available with stainless steel straps.



Model A3500

Steel Saddlemount - 50 Gallon

Tank Size: 24" diameter x 27" long
 Shipping Weight: 80#
 Mounting Kit Weight: 44#

Roll-formed cylindrical steel tank, domed ends are die stamped. Tank powder coated black. Filtered mushroom vent in tank top for increased air exchange. Filler/Breather assembly - including 40 micron filter/breather cap (chain mounted) with nylon strainer basket and bayonet closure. Three 1-1/4" NPT ports with built-in diffusers. Includes one 1-1/4" NPT plug. Includes AMK-624-C Mounting kit: two frame mount powder coated J-brackets (rubber shielded) and two rubber shielded, powder coated carbon steel strap assemblies. Unit is packaged in one carton and shipped by UPS.

Ordering Options

<i>Product</i>	<i>Product Description</i>
A3500	1-1/4" NPT bottom ports
A3500-ST	1-1/4" NPT bottom ports & Sight Temperature Gauge
A3500-15	1-1/2" NPT bottom ports
A3500-15ST	1-1/2" NPT bottom ports & Sight Temperature Gauge
* A3500-2	2" NPT bottom ports
* A3500-2ST	2" NPT bottom ports & Sight Temperature Gauge

*2" Ports are non-diffused

**CHANGES MAY BE MADE TO PRODUCT WITHOUT NOTICE.
 TO SEE OUR FULL LINE OF DRAWINGS GO TO WWW.AMERICANMOBILEPOWER.COM**

Order No.	Weight	Description	Page #
ABA-138	1#	Breather Vent - 3/8" NPT	39
APP-204	1#	Steel Port Plug - 1-1/4" NPT	41
ABC-315	1#	Filter/Breather Cap Only	39
AFC-330	2#	Fill Assembly	38
AMK-624-C	44#	Carbon Steel Mounting Kit Complete	34
AMT-350	80#	Steel Saddlemount Tank Only (50 Gallon)	

ALL TANKS FACTORY TESTED

OPTION: Available with stainless steel straps. Also available with a hose support mount.

Model A3525

Steel Saddlemount - 25 Gallon

Tank Size: 24" diameter x 15" long

Shipping Weight: 57#

Mounting Kit Weight: 44#



Roll-formed cylindrical steel tank, domed ends are die stamped. Tank powder coated black. Filler/Breather assembly - including 40 micron filter/breather cap (chain mounted) with nylon strainer basket and bayonet closure. Three 1-1/4" NPT ports with built-in diffusers. Includes one 1-1/4" NPT plug. Includes AMK-624-C Mounting Kit: two frame mount powder coated J-brackets (rubber shielded) and two rubber shielded, powder coated carbon steel strap assemblies. Unit is packaged in one carton and shipped by UPS.

Ordering Options

<i>Product</i>	<i>Product Description</i>
A3525	1-1/4" NPT bottom ports
A3525-ST	1-1/4" NPT bottom ports & Sight Temperature Gauge
* A3525-2	2" NPT bottom ports
* A3525-2ST	2" NPT bottom ports & Sight Temperature Gauge

*2" Ports are non-diffused

**CHANGES MAY BE MADE TO PRODUCT WITHOUT NOTICE.
TO SEE OUR FULL LINE OF DRAWINGS GO TO WWW.AMERICANMOBILEPOWER.COM**

Order No.	Weight	Description	Page #
AFC-330	2#	Fill Assembly	38
ABC-315	1#	Filter/Breather Cap Only	39
APP-204	1#	Steel Port Plug - 1-1/4" NPT	41
AMK-624-C	44#	Carbon Steel Mounting Kit Complete	34
AMT-352	57#	Steel Saddlemount Tank Only (25 Gal.)	

ALL TANKS FACTORY TESTED

OPTION: Available with stainless steel straps. Also available with a hose support mount.



Model A3535

Steel Saddlemount - 35 Gallon

Tank Size: 24" diameter x 19" long
 Shipping Weight: 62#
 Mounting Kit Weight: 44#

Roll-formed cylindrical steel tank, domed ends are die stamped. Tank powder coated black. Filler/Breather assembly - including 40 micron filter/breather cap (chain mounted) with nylon strainer basket and bayonet closure. Three 1-1/4" NPT ports with built-in diffusers. Includes one 1-1/4" NPT plug. Includes AMK-624-C Mounting kit: two frame mount powder coated J-brackets (rubber shielded) and two rubber shielded, powder coated carbon steel strap assemblies. Unit is packaged in one carton and shipped by UPS.

Ordering Options

<i>Product</i>	<i>Product Description</i>
A3535	1-1/4" NPT bottom ports
A3535-ST	1-1/4" NPT bottom ports & Sight Temperature Gauge
* A3535-2	2" NPT bottom ports
* A3535-2ST	2" NPT bottom ports & Sight Temperature Gauge

*2" Ports are non-diffused

CHANGES MAY BE MADE TO PRODUCT WITHOUT NOTICE.
TO SEE OUR FULL LINE OF DRAWINGS GO TO WWW.AMERICANMOBILEPOWER.COM

Order No.	Weight	Description	Page #
AFC-330	2#	Fill Assembly	38
ABC-315	1#	Filter/Breather Cap Only	39
APP-204	1#	Steel Port Plug - 1-1/4" NPT	41
AMK-624-C	44#	Carbon Steel Mounting Kit Complete	34
AMT-353	62#	Steel Saddlemount Tank Only (35 Gal.)	

ALL TANKS FACTORY TESTED

OPTION: Available with stainless steel straps. Also available with a hose support mount.

Model A3560-ST

Steel Saddlemount - 60 Gallon

Tank Size: 24" diameter x 33" long

Shipping Weight: 95#

Mounting Kit Weight: 44#



Roll-formed cylindrical steel tank, domed ends are die stamped. Tank powder coated black. Filtered mushroom vent in tank top for increased air exchange. Filler/Breather assembly - including 40 micron filter/breather cap (chain mounted) with nylon strainer basket and bayonet closure. Three 1-1/4" NPT ports with built-in diffusers. Includes one 1-1/4" NPT plug. Includes AMK-624-C Mounting kit: two frame mount powder coated J-brackets (rubber shielded) and two rubber shielded, powder coated carbon steel strap assemblies. Oil and temperature level indicator included. Unit is packaged in one carton and shipped by UPS.

Ordering Options

Product	Product Description
* A3560-2ST	2" NPT bottom ports & Sight Temperature Gauge

*2" Ports are non-diffused

**CHANGES MAY BE MADE TO PRODUCT WITHOUT NOTICE.
TO SEE OUR FULL LINE OF DRAWINGS GO TO WWW.AMERICANMOBILEPOWER.COM**

Order No.	Weight	Description	Page #
ABA-138	1#	Breather Vent - 3/8" NPT	39
APP-204	1#	Steel Port Plug - 1-1/4" NPT	41
ABC-315	1#	Filter/Breather Cap Only	39
AFC-330	2#	Fill Assembly	38
AMK-624-C	44#	Carbon Steel Mounting Kit Complete	34
AMT-356	95#	Steel Saddlemount Tank Only (60 Gallon)	
ASG-105	1#	Sight/Temperature Gauge	40

ALL TANKS FACTORY TESTED

OPTION: Available with stainless steel straps. Also available with a hose support mount.



Model A3575

Steel Saddlemount - 75 Gallon

Tank Size: 24" diameter x 39" long
 Shipping Weight: 115#
 Mounting Kit Weight: 63#

Roll-formed cylindrical steel tank, domed ends are die stamped; fully baffled. Tank powder coated black. Filtered mushroom vent in tank top for increased air exchange. Filler/Breather assembly - including 40 micron filter/breather cap (chain mounted) with nylon strainer basket and bayonet closure. Three 1-1/2" NPT ports with built-in diffusers. Includes one 1-1/2" NPT plug. Includes AMK-624-C3 Mounting kit: three frame mount powder coated J-brackets (rubber shielded) and three rubber shielded, powder coated carbon steel strap assemblies. Unit is packaged in two cartons and shipped by UPS.

Ordering Options

Product	Product Description
A3575	1-1/2" NPT bottom ports
A3575-ST	1-1/2" NPT bottom ports & Sight Temperature Gauge
* A3575-2	2" NPT bottom ports
* A3575 -2ST	2" NPT bottom ports & Sight Temperature Gauge

*2" Ports are non-diffused

CHANGES MAY BE MADE TO PRODUCT WITHOUT NOTICE.
TO SEE OUR FULL LINE OF DRAWINGS GO TO WWW.AMERICANMOBILEPOWER.COM

Order No.	Weight	Description	Page #
ABA-138	1#	Breather Vent - 3/8" NPT	39
APP-202	1#	Steel Port Plug - 1-1/2" NPT	41
ABC-315	1#	Filter/Breather Cap Only	39
AFC-330	2#	Fill Assembly	38
AMK-624-C/3	63#	Carbon Steel Mounting Kit Complete (75 Gal.)	35
AMT-357	115#	Steel Saddlemount Tank Only (75 Gal.)	

ALL TANKS FACTORY TESTED

OPTION: Available with stainless steel straps. Also available with a hose support mount.

Model A35100-ST

Steel Saddlemount - 100 Gallon

Tank Size: 24" diameter x 51" long

Shipping Weight: 138#

Mounting Kit Weight: 88#



Roll-formed cylindrical steel tank, domed ends are die stamped; fully baffled. Tank powder coated black. Two filtered mushroom vents in tank top for increased air exchange. Filler/Breather assembly - including 40 micron filter/breather cap (chain mounted) with nylon strainer basket and bayonet closure. Three 2" NPT ports. Bottom center port is diffused. Includes one 2" NPT plug. Two full baffles, providing a three compartment tank. Includes two AMK-624-C Mounting kits: four frame mount powder coated J-brackets (rubber shielded) and four rubber shielded, powder coated carbon steel strap assemblies. Oil and temperature level indicator included. Unit is packaged in one carton and shipped by truck freight.

**CHANGES MAY BE MADE TO PRODUCT WITHOUT NOTICE.
TO SEE OUR FULL LINE OF DRAWINGS GO TO WWW.AMERICANMOBILEPOWER.COM**

Order No.	Weight	Description	Page #
ABA-138	1#	Breather Vent - 3/8" NPT	39
APP-220	1#	Steel Port Plug - 2" NPT	41
ABC-315	1#	Filter/Breather Cap Only	39
AFC-330	2#	Fill Assembly	38
AMK-624-C	44#	Carbon Steel Mounting Kit Complete	34
AMT-351	138#	Steel Saddlemount Tank Only (100 Gallon)	
ASG-105	1#	Sight/Temperature Gauge	40

ALL TANKS FACTORY TESTED

OPTION: Available with stainless steel straps. Also available with a hose support mount.



Picture shown with stainless strap option.

Model A4500

Aluminum Saddlemount - 50 Gallon

Tank Size: 24" diameter x 27" long

Shipping Weight: 40#

Mounting Kit Weight: 44#

Roll-formed cylindrical aluminum tank, domed ends are die stamped; bright mill finish. Filtered mushroom vent in tank top for increased air exchange. Filler/Breather assembly - including 40 micron filter/breather cap (chain mounted) with nylon strainer basket and bayonet closure. Three heavy duty machined 1-1/4" NPT ports with built-in diffusers. One 1-1/4" NPT port plug included. Includes AMK-624-C Mounting kit: two frame mount powder coated J-brackets (rubber shielded) and two rubber shielded, powder coated carbon steel strap assemblies. Unit is packaged in one carton and shipped by UPS.

Ordering Options

<i>Product</i>	<i>Product Description</i>
A4500	1-1/4" NPT bottom ports
A4500-ST	1-1/4" NPT bottom ports & Sight Temperature Gauge
A4500-15	1-1/2" NPT bottom ports
A4500-15ST	1-1/2" NPT bottom ports & Sight Temperature Gauge
* A4500-2	2" NPT bottom ports
* A4500-2ST	2" NPT bottom ports & Sight Temperature Gauge

*2" Ports are non-diffused

CHANGES MAY BE MADE TO PRODUCT WITHOUT NOTICE.

TO SEE OUR FULL LINE OF DRAWINGS GO TO WWW.AMERICANMOBILEPOWER.COM

Order No.	Weight	Description	Page #
ABA-138	1#	Breather Vent - 3/8" NPT	39
APP-204	1#	Steel Port Plug - 1-1/4" NPT	41
ABC-315	1#	Filter/Breather Cap Only	39
AFC-330	2#	Fill Assembly	38
AMK-624-C	44#	Carbon Steel Mounting Kit Complete	34
AMT-450	40#	Aluminum Saddlemount Tank Only (50 Gal.)	

ALL TANKS FACTORY TESTED

OPTION: Available with stainless steel straps. Also available with a hose support mount (which is recommended.) Mirrored polished option also available.

Model A4525

Aluminum Saddlemount - 25 Gallon

Tank Size: 24" diameter x 15" long

Shipping Weight: 29#

Mounting Kit Weight: 44#



Picture shown with stainless strap option.

Roll-formed cylindrical aluminum tank, domed ends are die stamped. Bright mill finish. Filler/Breather assembly - including 40 micron filter/breather cap (chain mounted) with nylon strainer basket and bayonet closure. Three heavy duty machined 1-1/4" NPT ports with built-in diffusers. One 1-1/4" NPT port plug included. Includes AMK-624-C Mounting kit: two frame mount powder coated J-brackets (rubber shielded) and two rubber shielded, powder coated carbon steel strap assemblies. Unit is packaged in one carton and shipped UPS.

Ordering Options

Product	Product Description
A4525	1-1/4" NPT bottom ports
A4525-ST	1-1/4" NPT bottom ports & Sight Temperature Gauge
* A4525-2	2" NPT bottom ports
* A4525-2ST	2" NPT bottom ports & Sight Temperature Gauge

*2" Ports are non-diffused

**CHANGES MAY BE MADE TO PRODUCT WITHOUT NOTICE.
TO SEE OUR FULL LINE OF DRAWINGS GO TO WWW.AMERICANMOBILEPOWER.COM**

Order No.	Weight	Description	Page #
AFC-330	2#	Fill Assembly	38
ABC-315	1#	Filter/Breather Cap Only	39
APP-204	1#	Steel Port Plug - 1-1/4" NPT	41
AMK-624-C	44#	Carbon Steel Mounting Kit Complete	34
AMT-452	29#	Aluminum Saddlemount Tank Only (25 Gal.)	

ALL TANKS FACTORY TESTED

OPTION: Available with stainless steel straps. Also available with a hose support mount (which is recommended.) Mirrored polished option also available.



Picture shown with stainless strap option.

Model A4535

Aluminum Saddlemount - 35 Gallon

Tank Size: 24" diameter x 19" long

Shipping Weight: 32#

Mounting Kit Weight: 44#

Roll-formed cylindrical aluminum tank, domed ends are die stamped. Bright mill finish. Filler/Breather assembly - including 40 micron filter/breather cap (chain mounted) with nylon strainer basket and bayonet closure. Three heavy duty machined 1-1/4" NPT ports with built-in diffusers. One 1-1/4" NPT port plug included. Includes AMK-624-C Mounting kit: two frame mount powder coated J-brackets (rubber shielded) and two rubber shielded, powder coated carbon steel strap assemblies. Unit is packaged in one carton and shipped UPS.

Ordering Options

<i>Product</i>	<i>Product Description</i>
A4535	1-1/4" NPT bottom ports
A4535-ST	1-1/4" NPT bottom ports & Sight Temperature Gauge
* A4535-2	2" NPT bottom ports
* A4535-2ST	2" NPT bottom ports & Sight Temperature Gauge

*2" Ports are non-diffused

CHANGES MAY BE MADE TO PRODUCT WITHOUT NOTICE.

TO SEE OUR FULL LINE OF DRAWINGS GO TO WWW.AMERICANMOBILEPOWER.COM

Order No.	Weight	Description	Page #
AFC-330	2#	Fill Assembly	38
ABC-315	1#	Filter/Breather Cap Only	39
APP-204	1#	Steel Port Plug - 1-1/4" NPT	41
AMK-624-C	44#	Carbon Steel Mounting Kit Complete	34
AMT-453	32#	Aluminum Saddlemount Tank Only (35 Gal.)	

ALL TANKS FACTORY TESTED

OPTION: Available with stainless steel straps. Also available with a hose support mount (which is recommended.) Mirrored polished option also available.

Model A4560-ST

Aluminum Saddlemount - 60 Gallon

Tank Size: 24" diameter x 33" long

Shipping Weight: 50#

Mounting Kit Weight: 44#



Picture shown with stainless strap option.

Roll-formed cylindrical aluminum tank, domed ends are die stamped. Bright mill finish. Filtered mushroom vent in tank top for increased air exchange. Filler/Breather assembly - including 40 micron filter/breather cap (chain mounted) with nylon strainer basket and bayonet closure. Three heavy duty machined 1-1/4" NPT ports with built-in diffusers. One 1-1/4" NPT port plug included. Includes AMK-624-C Mounting kit: two frame mount powder coated J-brackets (rubber shielded) and two rubber shielded, powder coated carbon steel strap assemblies. Oil and temperature level indicator included. Unit is packaged in one carton and shipped UPS.

Ordering Options

Product	Product Description
* A4560-2ST	2" NPT bottom ports & Sight Temperature Gauge

*2" Ports are non-diffused

CHANGES MAY BE MADE TO PRODUCT WITHOUT NOTICE.
TO SEE OUR FULL LINE OF DRAWINGS GO TO WWW.AMERICANMOBILEPOWER.COM

Order No.	Weight	Description	Page #
ABA-138	1#	Breather Vent - 3/8" NPT	39
APP-204	1#	Steel Port Plug - 1-1/4" NPT	41
ABC-315	1#	Filter/Breather Cap Only	39
AFC-330	2#	Fill Assembly	38
AMK-624-C	44#	Carbon Steel Mounting Kit Complete	34
AMT-456	50#	Aluminum Saddlemount Tank Only (60 Gal.)	
ASG-105	1#	Sight/Temperature Gauge	40

ALL TANKS FACTORY TESTED

OPTION: Available with stainless steel straps. Also available with a hose support mount (which is recommended.) Mirrored polished option also available.



Picture shown with stainless strap option.

Model A4575

Aluminum Saddlemount - 75 Gallon

Tank Size: 24" diameter x 39" long

Shipping Weight: 55#

Mounting Kit Weight: 63#

Roll-formed cylindrical aluminum tank, domed ends are die stamped. Bright mill finish. Filtered mushroom vent in tank top for increased air exchange. Filler/Breather assembly - including 40 micron filter/breather cap (chain mounted) with nylon strainer basket and bayonet closure. Three heavy duty machined 1-1/2" NPT ports with built-in diffusers. One 1-1/2" NPT port plug included. Includes AMK-624-C3 Mounting kit: three frame mount powder coated J-brackets (rubber shielded) and three rubber shielded, powder coated carbon steel strap assemblies. Unit is packaged in one carton and shipped UPS.

Ordering Options

<i>Product</i>	<i>Product Description</i>
A4575	1-1/2" NPT bottom ports
A4575-ST	1-1/2" NPT bottom ports & Sight Temperature Gauge
* A4575-2	2" NPT bottom ports
* A4575-2ST	2" NPT bottom ports & Sight Temperature Gauge

*2" Ports are non-diffused

CHANGES MAY BE MADE TO PRODUCT WITHOUT NOTICE.

TO SEE OUR FULL LINE OF DRAWINGS GO TO WWW.AMERICANMOBILEPOWER.COM

Order No.	Weight	Description	Page #
ABA-138	1#	Breather Vent - 3/8" NPT	39
APP-202	1#	Steel Port Plug - 1-1/2" NPT	41
ABC-315	1#	Filter/Breather Cap Only	39
AFC-330	2#	Fill Assembly	38
AMK-624-C/3	63#	Carbon Steel Mounting Kit Complete (75 Gal.)	35
AMT-457	55#	Aluminum Saddlemount Tank Only (75 Gal.)	

ALL TANKS FACTORY TESTED

OPTION: Available with stainless steel straps. Also available with a hose support mount (which is recommended.) Mirrored polished option also available.

Model A45100-ST

Aluminum Saddlemount - 100 Gallon

Tank Size: 24" diameter x 51" long
 Shipping Weight: 92#
 Mounting Kit Weight: 88#



Picture shown with stainless strap option.

Roll-formed cylindrical aluminum tank, domed ends are die stamped. Bright mill finish. Two filtered mushroom vents in tank top for increased air exchange. Filler/Breather assembly - including 40 micron filter/breather cap (chain mounted) with nylon strainer basket and bayonet closure. Three heavy duty machined 2" NPT ports. Bottom center port is diffused. One 2" port plug included. Two full baffles, providing a three compartment tank. Includes two AMK-624-C Mounting kits: four frame mount powder coated J-brackets (rubber shielded) and four rubber shielded, powder coated carbon steel strap assemblies. Oil and temperature level indicator included. Unit is packaged in one carton and shipped by truck freight.

**CHANGES MAY BE MADE TO PRODUCT WITHOUT NOTICE.
 TO SEE OUR FULL LINE OF DRAWINGS GO TO WWW.AMERICANMOBILEPOWER.COM**

Order No.	Weight	Description	Page #
ABA-138	1#	Breather Vent - 3/8" NPT	39
APP-220	1#	Steel Port Plug - 2" NPT	41
ABC-315	1#	Filter/Breather Cap Only	39
AFC-330	2#	Fill Assembly	38
AMK-624-C	44#	Carbon Steel Mounting Kit Complete	34
AMT-451	92#	Aluminum Saddlemount Tank Only (100 Gal.)	
ASG-105	1#	Sight/Temperature Gauge	40

ALL TANKS FACTORY TESTED

OPTION: Available with stainless steel straps. Also available with a hose support mount (which is recommended.) Mirrored polished option also available.



Model A3107

Steel Sidemount - 7 Gallon

Tank Size: 12" long x 12" wide x 12" high
Shipping Weight: 40#

Steel tank assembly, fully baffled, with 2" x 2" x 6" mounting angles. Two 1-1/4" NPT suction ports; two 1" return line ports; magnetic drain plug; one 1-1/4" port plug and one 1" port plug. Powder coated black. Filler/breather assembly - including 40 micron filter/breather cap (chain mounted) with nylon strainer basket and bayonet closure. Oil level and temperature indicator. Unit is packaged in one carton and shipped UPS.

CHANGES MAY BE MADE TO PRODUCT WITHOUT NOTICE.
TO SEE OUR FULL LINE OF DRAWINGS GO TO WWW.AMERICANMOBILEPOWER.COM

Order No.	Weight	Description	Page #
ASG-105	1#	Sight/Temperature Gauge	40
AFC-330	2#	Fill Assembly	38
ABC-315	1#	Filter/Breather Cap Only	39
APP-204	1#	Steel Port Plug - 1-1/4" NPT	41
APP-210-M	1#	Magnetic Port Plug - 3/4" NPT	41
APP-210	1#	Steel Port Plug - 1" NPT	41

ALL TANKS FACTORY TESTED

Model A3100

Steel Sidemount - 10 Gallon

Tank Size: 12" long x 14" wide x 14" high

Shipping Weight: 45#



Steel tank assembly, fully baffled, with pre-punched and slotted 2" x 2" mounting angles. Two 1-1/4" NPT suction ports; two 1" return line ports; magnetic drain plug; one 1-1/4" port plug and one 1" port plug. Powder coated black. Filler/breather assembly - including 40 micron filter/breather cap (chain mounted) with nylon strainer basket and bayonet closure. Oil level and temperature indicator. Unit is packaged in one carton and shipped UPS.

**CHANGES MAY BE MADE TO PRODUCT WITHOUT NOTICE.
TO SEE OUR FULL LINE OF DRAWINGS GO TO WWW.AMERICANMOBILEPOWER.COM**

Order No.	Weight	Description	Page #
ASG-105	1#	Sight/Temperature Gauge	40
AFC-330	2#	Fill Assembly	38
ABC-315	1#	Filter/Breather Cap Only	39
APP-204	1#	Steel Port Plug - 1-1/4" NPT	41
APP-210-M	1#	Magnetic Port Plug - 3/4" NPT	41
APP-210	1#	Steel Port Plug - 1" NPT	41

ALL TANKS FACTORY TESTED



Model A3150

Steel Sidemount - 15 Gallon

Tank Size: 16" long x 14" wide x 16" high
Shipping Weight: 62#

Steel tank assembly, fully baffled, with pre-punched and slotted 2" x 2" mounting angles. Two 2" NPT suction ports; two 1-1/4" return line ports; magnetic drain plug; one 2" port plug and one 1-1/4" port plug. Powder coated black. Filler/breather assembly - including 40 micron filter/breather cap (chain mounted) with nylon strainer basket and bayonet closure. Oil level and temperature indicator. Unit is packaged in one carton and shipped UPS.

CHANGES MAY BE MADE TO PRODUCT WITHOUT NOTICE.
TO SEE OUR FULL LINE OF DRAWINGS GO TO WWW.AMERICANMOBILEPOWER.COM

Order No.	Weight	Description	Page #
ASG-105	1#	Sight/Temperature Gauge	40
AFC-330	2#	Fill Assembly	38
ABC-315	1#	Filter/Breather Cap Only	39
APP-204	1#	Steel Port Plug - 1-1/4" NPT	41
APP-210-M	1#	Magnetic Port Plug - 3/4" NPT	41
APP-220	1#	Steel Port Plug - 2" NPT	41

ALL TANKS FACTORY TESTED

OPTION: Installed inspection port with 6" cover.

Model A3250

Steel Sidemount - 25 Gallon

Tank Size: 20" long x 15" wide x 20" high
Shipping Weight: 84#



Steel tank assembly, fully baffled, with pre-punched and slotted 2" x 2" mounting angles. Two 2" NPT suction ports; two 1-1/4" return line ports; magnetic drain plug; one 2" port plug and one 1-1/4" port plug. Powder coated black. Filler/breather assembly - including 40 micron filter/breather cap (chain mounted) with nylon strainer basket and bayonet closure. Oil level and temperature indicator. Unit is packaged in one carton and shipped UPS.

**CHANGES MAY BE MADE TO PRODUCT WITHOUT NOTICE.
TO SEE OUR FULL LINE OF DRAWINGS GO TO WWW.AMERICANMOBILEPOWER.COM**

Order No.	Weight	Description	Page #
ASG-105	1#	Sight/Temperature Gauge	40
AFC-330	2#	Fill Assembly	38
ABC-315	1#	Filter/Breather Cap Only	39
APP-204	1#	Steel Port Plug - 1-1/4" NPT	41
APP-210-M	1#	Magnetic Port Plug - 3/4" NPT	41
APP-220	1#	Steel Port Plug - 2" NPT	41

ALL TANKS FACTORY TESTED

OPTION: Installed inspection port with 6" cover.



Model A3300

Steel Sidemount - 30 Gallon

Tank Size: 24" long x 15" wide x 20" high

Shipping Weight: 98#

Steel tank assembly, fully baffled, with pre-punched and slotted 2" x 2" mounting angles. Two 2" NPT suction ports; two 1-1/4" return line ports; magnetic drain plug; one 2" port plug and one 1-1/4" port plug. Powder coated black. Filler/breather assembly - including 40 micron filter/breather cap (chain mounted) with nylon strainer basket and bayonet closure. Oil level and temperature indicator. Unit is packaged in one carton and shipped UPS.

CHANGES MAY BE MADE TO PRODUCT WITHOUT NOTICE.

TO SEE OUR FULL LINE OF DRAWINGS GO TO WWW.AMERICANMOBILEPOWER.COM

Order No.	Weight	Description	Page #
ASG-105	1#	Sight/Temperature Gauge	40
AFC-330	2#	Fill Assembly	38
ABC-315	1#	Filter/Breather Cap Only	39
APP-204	1#	Steel Port Plug - 1-1/4" NPT	41
APP-210-M	1#	Magnetic Port Plug - 3/4" NPT	41
APP-220	1#	Steel Port Plug - 2" NPT	41

ALL TANKS FACTORY TESTED

OPTION: Installed inspection port with 6" cover.

Model A3400

Steel Sidemount - 40 Gallon

Tank Size: 36" long x 12" wide x 20" high

Shipping Weight: 126#



Steel tank assembly, fully baffled, with pre-punched and slotted 2" x 2" mounting angles. Two 2" NPT suction ports; two 1-1/4" return line ports; magnetic drain plug; one 2" port plug and one 1-1/4" port plug. Powder coated black. Filler/breather assembly - including 40 micron filter/breather cap (chain mounted) with nylon strainer basket and bayonet closure. Oil level and temperature indicator. Unit is packaged in one carton and shipped UPS.

**CHANGES MAY BE MADE TO PRODUCT WITHOUT NOTICE.
TO SEE OUR FULL LINE OF DRAWINGS GO TO WWW.AMERICANMOBILEPOWER.COM**

Order No.	Weight	Description	Page #
ASG-105	1#	Sight/Temperature Gauge	40
AFC-330	2#	Fill Assembly	38
ABC-315	1#	Filter/Breather Cap Only	39
APP-204	1#	Steel Port Plug - 1-1/4" NPT	41
APP-210-M	1#	Magnetic Port Plug - 3/4" NPT	41
APP-220	1#	Steel Port Plug - 2" NPT	41

ALL TANKS FACTORY TESTED

OPTION: Installed inspection port with 6" cover.



Model A4150

Aluminum Sidemount - 15 Gallon

Tank Size: 16" long x 14" wide x 16" high

Shipping Weight: 31#

Aluminum tank assembly constructed of Bright Diamond Plate and bright mill finish, fully baffled, with 2" x 2" mounting angles. Two heavy duty, machined 2" NPT suction ports; two heavy duty machined 1-1/4" return line ports; magnetic drain plug; one 2" port plug and one 1-1/4" port plug. Filler/Breather assembly - including 40 micron filter/breather cap (chain mounted) with nylon strainer basket and bayonet closure. Oil level and temperature indicator. Unit is packaged in one carton and shipped UPS.

CHANGES MAY BE MADE TO PRODUCT WITHOUT NOTICE.

TO SEE OUR FULL LINE OF DRAWINGS GO TO WWW.AMERICANMOBILEPOWER.COM

Order No.	Weight	Description	Page #
ASG-105	1#	Sight/Temperature Gauge	40
APP-204	1#	Steel Port Plug - 1-1/4" NPT	41
APP-220	1#	Steel Port Plug - 2" NPT	41
ABC-315	1#	Filter/Breather Cap Only	39
APP-210-M	1#	Magnetic Port Plug - 3/4" NPT	41
AFC-330	2#	Fill Assembly	38

ALL TANKS FACTORY TESTED

OPTION: Installed inspection port with 6" cover.

Specialty Hydraulic Tanks

Model A330SL

Specialty Hydraulic Tank: 30 Gallon

Tank Size: 15" long x 19" wide x 25" high

Shipping Weight: 96#



Steel tank assembly, fully baffled, with pre-punched and slotted 2" x 2" mounting angles. Angles are rear mounted with an extra (2) pre-punched and slotted 2" x 2" angles (shipped loose) for adjustable mounting with your specific application. One 2" NPT suction port; one 1-1/4" return line port. Filter/breather assembly - including 40 micron filter/breather cap (chain mounted) with nylon strainer and bayonet closure. Oil level and temperature indicator gauge. Unit is packaged in one carton and shipped UPS.

Also available in 20 and 25 gallon.

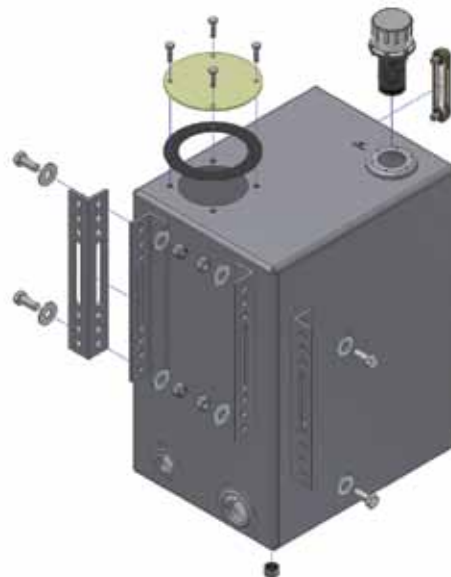

Specialty Hydraulic Tanks

Model A4535-DS90-ST

Specialty Aluminum Saddlemount Tank: 35 Gallon

Tank Size: 24" diameter x 19" long

Shipping Weight: 32#

Mounting Kit Weight: 44#



Roll-formed cylindrical aluminum tank, domed ends are die stamped. Bright mill finished. Includes (1) 2" NPT heavy duty machined suction port and (1) 1-1/4" NPT heavy duty machined return line port. Both ports are rear facing for easy and convenient wet line installation. Filter/breather assembly - including 40 micron filter/breather cap (chain mounted) with nylon strainer and bayonet closure. Oil level and temperature indicator gauge (can be mounted on either end of tank.) Includes AMK-624-C Mounting kit: two frame mounted powder coated J-Brackets (rubber shielded) and two rubber shielded, powder coated carbon steel strap assemblies. Unit is packaged in one carton and shipped UPS. Also available in steel.

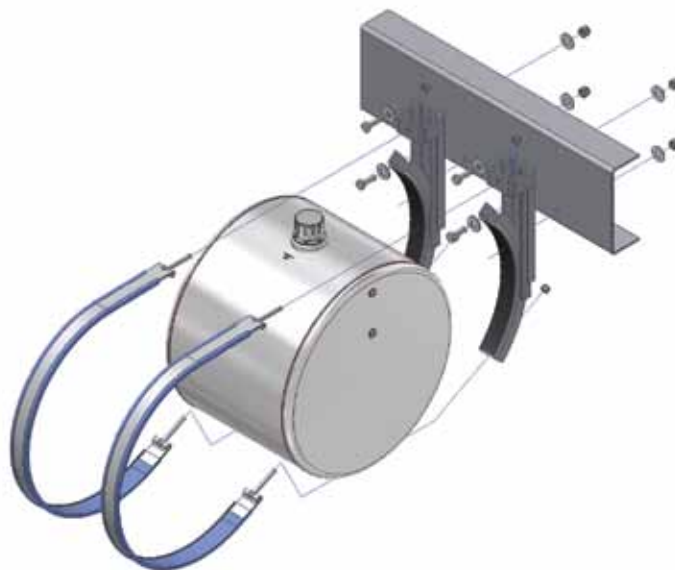

Specialty Hydraulic Tanks

Model A4500-2S90-ST

Specialty Aluminum Saddlemount Tank: 50 Gallon

Tank Size: 24" diameter x 27" long

Shipping Weight: 40#

Mounting Kit Weight: 44#

Roll-formed cylindrical aluminum tank, domed ends are die stamped. Bright mill finished. Includes (2) 2" NPT heavy duty machined ports. Both ports are rear facing for easy and convenient wet line installation. Filter/breather assembly - including 40 micron filter/breather cap (chain mounted) with nylon strainer and bayonet closure. Oil level and temperature indicator gauge (can be mounted on either end of tank.) Includes AMK-624-C Mounting kit: two frame mounted powder coated J-Brackets (rubber shielded) and two rubber shielded, powder coated carbon steel strap assemblies. Unit is packaged in one carton and shipped UPS.

Also available in 75 gallons and in steel.

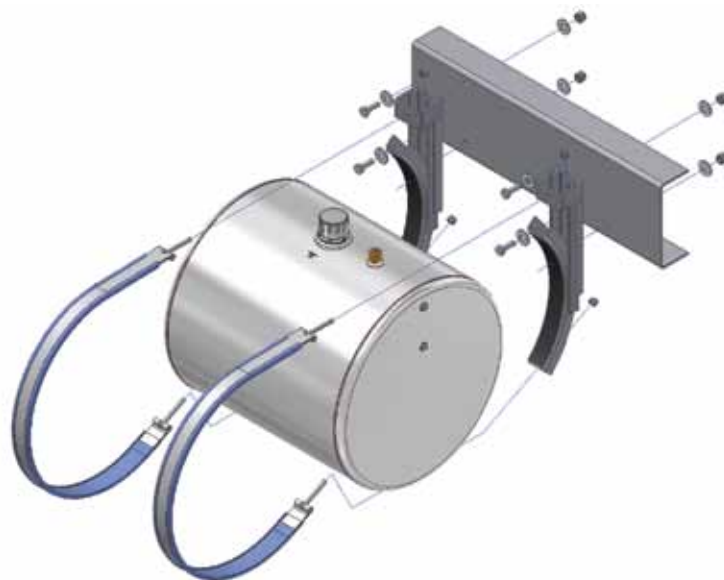



Hydraulic Mounting Products

Saddlemount - Mounting Kits

AMK-624-C & AMK-624-S

For 25, 35, 50, & 100 Gallon Capacity Tanks

AMK-624-C

Weight: 44#

AMK-624-C Carbon Mounting kit is shipped standard with all Steel and Aluminum Saddlemount tanks with a gallon capacity of less than 75 gallon. This kit includes: Two frame mount powder coated J-brackets (rubber shielded) and two rubber shielded, powder coated carbon steel strap assemblies. Kit can be purchased separately.

AMK-624-S

Weight: 44#

AMK-624-S Stainless Mounting kit is available as an upgrade option from the standard AMK-624-C. This kit is usable with Saddlemount tanks that are less than 75 gallons. Mounting kit includes: two frame mount powder coated J-brackets (rubber shielded) and two rubber shielded, stainless steel strap assemblies. Kit can be purchased separately.



CHANGES MAY BE MADE TO PRODUCT WITHOUT NOTICE.

TO SEE OUR FULL LINE OF DRAWINGS GO TO WWW.AMERICANMOBILEPOWER.COM

Order No.	Weight	Description	Page #
AMK-624	16#	"J" Bracket Only	37
ASA-355	7#	Carbon Steel Strap Assembly *for AMK-624-C	37
ASA-355-S	5#	Stainless Steel Strap Assembly *for AMK-624-S	37

NOTE: The 100 gallon Saddlemount Tanks (A35100-ST and A45100-ST) are supplied with two of the above kits.

Hydraulic Mounting Products

Saddlemount - Mounting Kits

AMK-624-C/3 & AMK-624-S/3

For 75 Gallon Saddlemount Tanks

AMK-624-C/3

Carbon Mounting Kit: 75 Gal.

Weight: 63#

AMK-624-C/3 Carbon Mounting kit is shipped standard with the A3575 and the A4575; 75 gallon capacity saddlemount hydraulic tanks. This mounting kit includes: Three frame mount powder coated J-brackets (rubber shielded) and three rubber shielded, powder coated carbon steel strap assemblies. Kit can be purchased separately.

AMK-624-S/3

Stainless Mounting Kit: 75 Gal.

Weight: 63#

AMK-624-S Stainless Mounting kit is available as an upgrade option from the standard AMK-624-C. This kit is usable with Saddlemount tanks that are of 75 gallon capacity. Mounting kit includes: three frame mount powder coated J-brackets (rubber shielded) and three rubber shielded, stainless steel strap assemblies. Kit can be purchased separately.



CHANGES MAY BE MADE TO PRODUCT WITHOUT NOTICE.
TO SEE OUR FULL LINE OF DRAWINGS GO TO WWW.AMERICANMOBILEPOWER.COM

Order No.	Weight	Description	Page #
AMK-624	16#	“J” Bracket Only	37
ASA-355	7#	Carbon Steel Strap Assembly *for AMK-624-C	37
ASA-355-S	5#	Stainless Steel Strap Assembly *for AMK-624-S	37



Hydraulic Mounting Products

Upright - Mounting Kits

ABK-340-C & ABK-340-S

For 70 Gallon Upright Tanks

ABK-340-C

Carbon Mounting Kit: 70 Gal.

Weight: 63#

The ABK-340-C Mounting kit comes standard with the A3070 and the A4070 hydraulic upright tanks. Mounting kit includes: Mounting base panel, carbon steel strap assembly with springs and rubber mounting pads. Also supplied is the ASK-200 mounting kit which includes four pre-drilled powder coated mounting angles, plated bolts, washers, nyloc-nuts, four plated springs, and four mounting pads. Also includes filter/breather cap and auxillary vent. Ships in one carton.

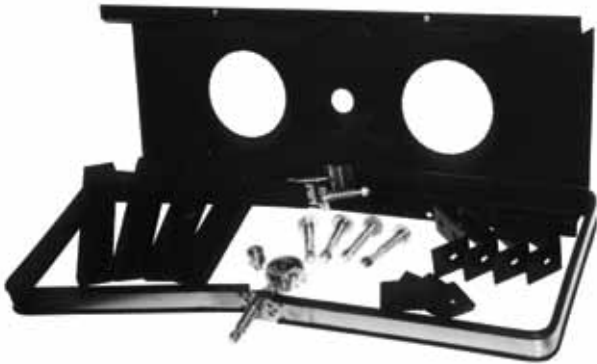

ABK-340-S

Stainless Mounting Kit: 70 Gal.

Weight: 63#

The ABK-340-S Stainless Mounting kit is available as an upgrade option from the ABK-340C. This mounting kit is usable with the 70 gallon upright tanks. Mounting kit includes: Mounting base panel, stainless steel strap assembly with springs and rubber mounting pads. Also supplied is the ASK-200 mounting kit which includes four pre-drilled powder coated mounting angles, plated bolts, washers, nyloc-nuts, four plated springs, and four mounting pads. Also includes filter/breather cap and auxillary vent.

CHANGES MAY BE MADE TO PRODUCT WITHOUT NOTICE.









TO SEE OUR FULL LINE OF DRAWINGS GO TO WWW.AMERICANMOBILEPOWER.COM

Order No.	Weight	Description	Page #
AMB-405HD	20#	Mounting Base Panel - Heavy Duty	37
AMP-205	5#	Rubber Inserts for Heavy Duty Mounting Base Panel	37
ASK-200	12#	Chassis Mounting Kit	37
ASA-355	7#	Carbon Steel Strap Assembly (ABK-340-C)	37
ASA-355-S	5#	Stainless Steel Strap Assembly (ABK-340-S)	37

Hydraulic Mounting Products

Mounting Kit Parts

CHANGES MAY BE MADE TO PRODUCT WITHOUT NOTICE.
TO SEE OUR FULL LINE OF DRAWINGS GO TO WWW.AMERICANMOBILEPOWER.COM

Order No.	Weight	Description	
AMB-312	20#	Mounting Base Panel	
AMB-405HD	20#	Mounting Base Panel - Heavy Duty	
AMK-624	14#	"J" Bracket Only	
ASA-355	7#	Carbon Steel Strap Assembly Strap Length with T-Bolt - 63" Strap Length without T-Bolt - 57"	
ASA-355-S	5#	Stainless Steel Strap Assembly Strap Length with T-Bolt - 63" Strap Length without T-Bolt - 57"	
AMP-400	1#	Channel Rubber Sold per foot	
AMP-40053	3#	53" Channel Rubber (for strap)	
ASK-200	12#	Chassis Mounting Kit	
ASK-210	20#	Heavy Duty Chassis Mounting Kit	
AMP-305	1#	"J" Bracket Rubber	
AMP-205	5#	Rubber Inserts for Heavy Duty Mounting Base Panel	
ASK-200G	12#	2.5" x 2.5" x 4" Gusseted Mounting Kit	



Fill Assembly Products

Fill Assemblies

CHANGES MAY BE MADE TO PRODUCT WITHOUT NOTICE.
 TO SEE OUR FULL LINE OF DRAWINGS GO TO WWW.AMERICANMOBILEPOWER.COM

Order No.	Weight	Description
FCS-557	1#	Non-Vented Cap Assembly
AFC-330	1#	Fill Cap Assembly w/out cap
AFC-350	1#	Fill Cap Assembly
57XL-10-6DP	1#	Fill Cap Assembly w/ 6" Dipstick
57XL-10-3HN	1#	Fill Cap Assembly w/ 3" Riser Cup with 3" Flange
LC57XL-40N	1#	Lockable Fill Cap Assembly Vented
57XL-40-5P	2#	Fill Assembly w/ Pressure Cap 5 psi breather
FCS-537W	1#	Filler Cap Assembly Weather Proof

Fill Assembly Products

Fill Assembly Parts

CHANGES MAY BE MADE TO PRODUCT WITHOUT NOTICE.
TO SEE OUR FULL LINE OF DRAWINGS GO TO WWW.AMERICANMOBILEPOWER.COM

Order No.	Weight	Description	
ABC-315	1#	Filter/Breather Cap Only	
ABA-138	1#	Breather Vent - 3/8" NPT Solid steel body, plated cover, 60 psi fully reticulated open core charcoal foam filter.	
ABA-12	1#	Breather Vent - 3/4" NPT	
ABA-16	1#	Breather Vent - 1" NPT	
HDF-6	2#	Diesel Fuel Neck	



Hydraulic Tank Parts

CHANGES MAY BE MADE TO PRODUCT WITHOUT NOTICE.
TO SEE OUR FULL LINE OF DRAWINGS GO TO WWW.AMERICANMOBILEPOWER.COM

Order No.	Weight	Description	
ASG-105	1#	Sight/temperature Gauge	
ADA-250	2#	Diffuser Assembly 8" Long - 2" to 1-1/4"	
LIT-1250-10P	6#	In Tank Filter	
LTM-50	3#	Suction Strainer, 3" to 2"	
LTM-25	2#	NPT Suction Strainer With Bypass, 2" to 1-1/4"	
APC-160	2#	6" Inspection Port Cover	
APC-160-S	2#	6" Inspection Stainless Port Cover	

Hydraulic Parts

CHANGES MAY BE MADE TO PRODUCT WITHOUT NOTICE.
TO SEE OUR FULL LINE OF DRAWINGS GO TO WWW.AMERICANMOBILEPOWER.COM

Order No.	Weight	Description	
<u>STEEL WELD FLANGES</u>			
AFS-050	1#	1/2" Steel Weld Flange	
AFS-075	1#	3/4" Steel Weld Flange	
AFS-100	1#	1" Steel Weld Flange	
AFS-125	1#	1-1/4" Steel Weld Flange	
AFS-150	1#	1-1/2" Steel Weld Flange	
AFS-200	1#	2" Steel Weld Flange	
AFS-301	1#	Steel Fill Adapter	
<u>ALUMINUM WELD FLANGES</u>			
AFA-038	1#	3/8" Aluminum Weld Flange	
AFA-050	1#	1/2" Aluminum Weld Flange	
AFA-075	1#	3/4" Aluminum Weld Flange	
AFA-100	1#	1" Aluminum Weld Flange	
AFA-125	1#	1-1/4" Aluminum Weld Flange	
AFA-150	1#	1-1/2" Aluminum Weld Flange	
AFA-200	1#	2" Aluminum Weld Flange	
AFA-401	1#	Aluminum Fill Adapter	
<u>STEEL PORT PLUGS & REDUCER BUSHINGS</u>			
APP-210	1#	Steel Port Plug - 1" NPT	
APP-204	1#	Steel Port Plug - 1-1/4" NPT	
APP-202	1#	Steel Port Plug - 1-1/2" NPT	
APP-220	1#	Steel Port Plug - 2" NPT	
APP-210-M	1#	Magnetic Port Plug - 3/4" NPT	
APP-225	1#	Port Reducer Bushing - plated, 2" x 1-1/4"	



Hydraulic Accessories

Wet Line Hose Kits

3 Line Systems

WL-HK-9-8-3L

9' Pressure/8' Suction
Shipping Weight: 24#

WL-HK-12-12-3L

12' Pressure/12' Suction
Shipping Weight: 32#

WL-HK-16-24-3L

16' Pressure/(2) 12' Suction
Shipping Weight: 40#

WL-HK-20-24-3L

20' Pressure/(2) 12' Suction
Shipping Weight: 44#



CHANGES MAY BE MADE TO PRODUCT WITHOUT NOTICE.

TO SEE OUR FULL LINE OF DRAWINGS GO TO WWW.AMERICANMOBILEPOWER.COM

Order No.	Weight	Description	Qty./Kit	Page #
AQD-1010	5#	1" Quick Disconnect-Complete	1 each	45
AHB-125	1#	1-1/4" NPT Male Hose Barb	4 each	
AHC-150	1#	Hose clamp Wormdrive	4 each	
APH-1	2#	1" SAE 100 R17 Pressure Hose	ft.-see kit	
ASH-125	2#	1-1/4" SAE 100 R4 Suction Hose	ft.-see kit	

Hydraulic Accessories

Wet Line Hose Kits

2 Line Systems

WL-HK-12-6-2L

12' Pressure/6' Suction
Shipping Weight: 22#

WL-HK-14-8-2L

14' Pressure/8' Suction
Shipping Weight: 26#

WL-HK-16-8-2L

16' Pressure/8' Suction
Shipping Weight: 30#

WL-HK-20-12-2L

20' Pressure/12' Suction
Shipping Weight: 34#



CHANGES MAY BE MADE TO PRODUCT WITHOUT NOTICE.
TO SEE OUR FULL LINE OF DRAWINGS GO TO WWW.AMERICANMOBILEPOWER.COM

Order No.	Weight	Description	Qty./Kit	Page #
AQD-1010	5#	1" Quick Disconnect-Complete	1 each	45
AHB-125	1#	1-1/4" NPT Male Hose Barb	2 each	
AHC-150	1#	Hose clamp Wormdrive	2 each	
APH-1	2#	1" SAE 100 R17 Pressure Hose	ft.-see kit	
ASH-125	2#	1-1/4" SAE 100 R4 Suction Hose	ft.-see kit	

Hydraulic Accessories

Hose Support Kits



AHS-125

For use with 1-1/4" hose application
Shipping Weight: 5#

AHS-150

For use with 1-1/2" hose application
Shipping Weight: 7#

AHS-200

For use with 2" hose application
Shipping Weight: 9#

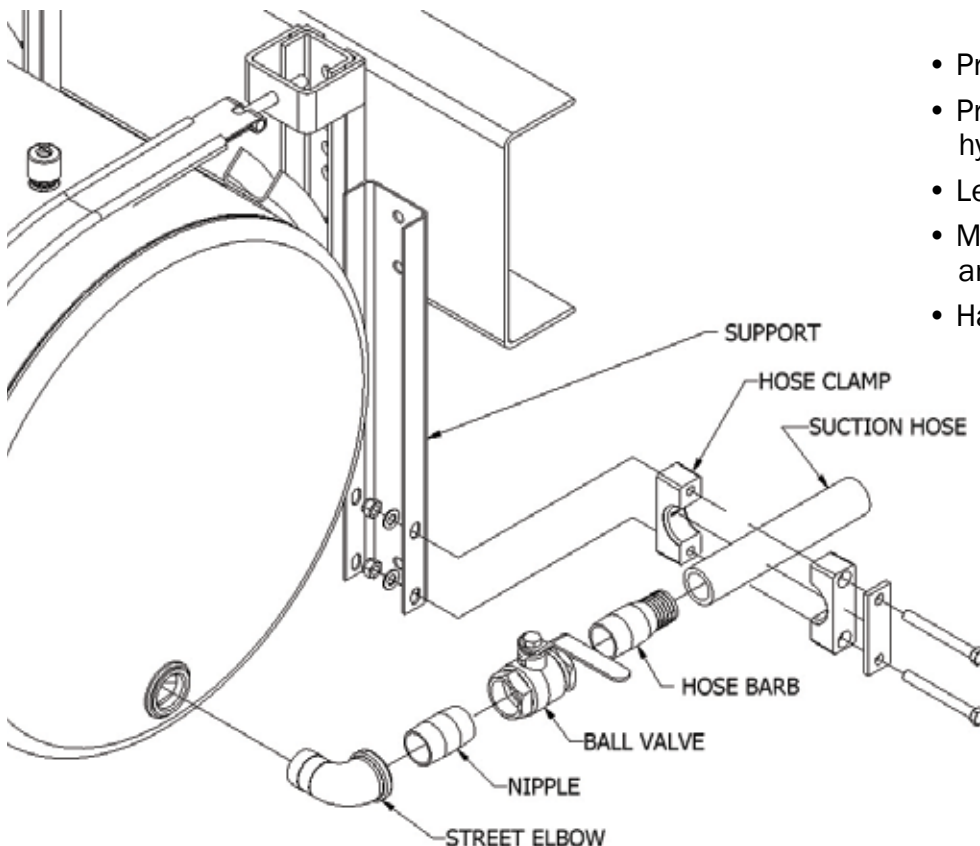

- Prevents stress on ports
- Precision clamps - designed for hydraulic hose diameters
- Left or right applications
- Mounting bracket pre-punched and powder coated
- Hardware supplied

Hydraulic Accessory Parts

CHANGES MAY BE MADE TO PRODUCT WITHOUT NOTICE.
TO SEE OUR FULL LINE OF DRAWINGS GO TO WWW.AMERICANMOBILEPOWER.COM

Order No.	Weight	Description	
AQD-1010	5#	1" Quick Disconnect-Complete	
AQM-1010	2#	1" Male Coupler End	
AQF-1010	2#	1" Female Coupler End	
ARM-1010	1#	Rapid Mount Assembly	
LPBV-20	1#	1-1/4" Low Pressure Ball Valve	



American Transfer Tank System

Model ATT4070

Aluminum Upright - 70 Gallon

Tank Size: 46.5" long x 13" deep x 26" high
Shipping Weight: 74#

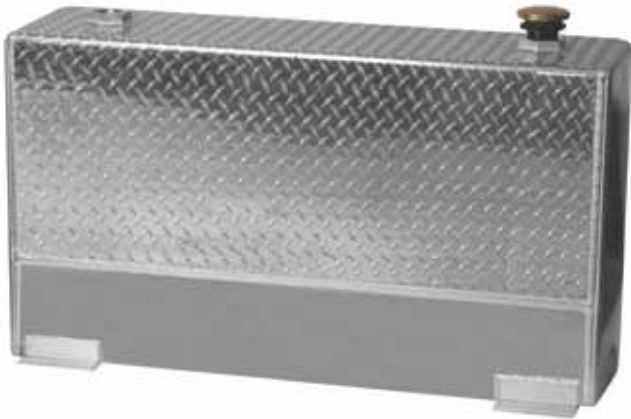

Total aluminum construction; top tank section built of Bright Diamond Plate, balance mill finish; fully baffled; two 2" machined hexfixing NPT ports in top ends of tank to accommodate transfer pump and/or vented cap, ports are internally reinforced. 2" NPT lockable vented cap provided; four 4" long 2" x 2" angles welded in place for secure deck mounting; 3/4" NPT drain port with plug located at bottom edge of left head. Ships by truck freight.

CHANGES MAY BE MADE TO PRODUCT WITHOUT NOTICE.
TO SEE OUR FULL LINE OF DRAWINGS GO TO WWW.AMERICANMOBILEPOWER.COM

Order No.	Weight	Description	Page #
APP-210-M	1#	Magnetic Port Plug - 3/4" NPT	54
906001-4	1#	2" NPT Vented Cap	54

ALL TANKS FACTORY TESTED

It is the users responsibility to comply with local, state, and federal requirements. Tanks are intended for use with non-hazardous fluids and fluids with a flash point greater than 100 deg. F.

WARNING! Transfer tanks must not be connected to a vehicle fuel system as an auxiliary fuel tank.

American Transfer Tank System

Model ATT4090

Aluminum Upright - 90 Gallon

Tank Size: 61" long x 13" deep x 26" high

Shipping Weight: 87#



Total aluminum construction; top tank section built of Bright Diamond Plate, balance mill finish; fully baffled; two 2" machined hexfixing NPT ports in top ends of tank to accommodate transfer pump and/or vented cap, ports are internally reinforced. 2" NPT lockable vented cap provided; four 4" long 2" x 2" angles welded in place for secure deck mounting; 3/4" NPT drain port with plug located at bottom edge of left head. Ships by truck freight.

CHANGES MAY BE MADE TO PRODUCT WITHOUT NOTICE.

TO SEE OUR FULL LINE OF DRAWINGS GO TO WWW.AMERICANMOBILEPOWER.COM

Order No.	Weight	Description	Page #
APP-210-M	1#	Magnetic Port Plug - 3/4" NPT	54
906001-4	1#	2" NPT Vented Cap	54

ALL TANKS FACTORY TESTED

It is the users responsibility to comply with local, state, and federal requirements. Tanks are intended for use with non-hazardous fluids and fluids with a flash point greater than 100 deg. F.

WARNING! Transfer tanks must not be connected to a vehicle fuel system as an auxiliary fuel tank.



American Transfer Tank System

Model ATT4072

Aluminum Deck Mount - 72 Gallon

Tank Size: 42" long x 20" deep x 20" high

Shipping Weight: 69#



Total aluminum construction; top, front and back sides built of Bright Diamond Plate, balance mill finish; fully baffled; two 2" machined hexfixing NPT ports in top ends of tank to accommodate transfer pump and/or vented cap, ports are internally reinforced. 2" NPT lockable vented cap provided; two 12" long 2" x 2" angles welded to ends of tank for secure deck mounting; 3/4" NPT drain port with plug located at bottom edge of left head. Ships by truck freight.

CHANGES MAY BE MADE TO PRODUCT WITHOUT NOTICE.

TO SEE OUR FULL LINE OF DRAWINGS GO TO WWW.AMERICANMOBILEPOWER.COM

Order No.	Weight	Description	Page #
APP-210-M	1#	Magnetic Port Plug - 3/4" NPT	54
906001-4	1#	2" NPT Vented Cap	54

ALL TANKS FACTORY TESTED

It is the users responsibility to comply with local, state, and federal requirements. Tanks are intended for use with non-hazardous fluids and fluids with a flash point greater than 100 deg. F.

WARNING! Transfer tanks must not be connected to a vehicle fuel system as an auxiliary fuel tank.

American Transfer Tank System

Model ATT41020

Aluminum Deck Mount - 102 Gallon

Tank Size: 59" long x 20" deep x 20" high

Shipping Weight: 88#



Total aluminum construction; top, front and back sides built of Bright Diamond Plate, balance mill finish; fully baffled; two 2" machined hexfixing NPT ports in top ends of tank to accommodate transfer pump and/or vented cap, ports are internally reinforced. 2" NPT lockable vented cap provided; two 12" long 2" x 2" angles welded to ends of tank for secure deck mounting; 3/4" NPT drain port with plug located at bottom edge of left head. Ships by truck freight.

CHANGES MAY BE MADE TO PRODUCT WITHOUT NOTICE.
TO SEE OUR FULL LINE OF DRAWINGS GO TO WWW.AMERICANMOBILEPOWER.COM

Order No.	Weight	Description	Page #
APP-210-M	1#	Magnetic Port Plug - 3/4" NPT	54
906001-4	1#	2" NPT Vented Cap	54
ALL TANKS FACTORY TESTED			

It is the users responsibility to comply with local, state, and federal requirements. Tanks are intended for use with non-hazardous fluids and fluids with a flash point greater than 100 deg. F.

WARNING! Transfer tanks must not be connected to a vehicle fuel system as an auxiliary fuel tank.



American Transfer Tank System

Model ATT4075

Aluminum "L" Style - 75 Gallon

Tank Size: 48" long x 30" deep x 18" high

Designed for full size, short bed, dub cap pickups.

Shipping Weight: 95#



Features: Low profile height
All bright tread finish
75 Gallon capacity

Total aluminum construction; all exposed surfaces built of Bright Diamond Plate; dual built-in baffles; two 2" machined hexfixing NPT ports in top ends of tank to accommodate transfer pump and/or vented cap, ports are internally reinforced. 2" NPT lockable vented cap provided; four 6" long 2" x 2" angles welded in place for secure deck mounting; 3/4" NPT drain port with plug located at bottom edge of left head. Ships by truck freight.

CHANGES MAY BE MADE TO PRODUCT WITHOUT NOTICE.

TO SEE OUR FULL LINE OF DRAWINGS GO TO WWW.AMERICANMOBILEPOWER.COM

Order No.	Weight	Description	Page #
APP-210-M	1#	Magnetic Port Plug - 3/4" NPT	54
906001-4	1#	2" NPT Vented Cap	54

ALL TANKS FACTORY TESTED

It is the users responsibility to comply with local, state, and federal requirements. Tanks are intended for use with non-hazardous fluids and fluids with a flash point greater than 100 deg. F.

WARNING! Transfer tanks must not be connected to a vehicle fuel system as an auxiliary fuel tank.

American Transfer Tank System

Model ATT4088

Aluminum “L” Style - 100 Gallon

Tank Size: 54” long x 30” deep x 26” high

Designed for full size pickups.

Shipping Weight: 136#



Total aluminum construction; top facing built of Bright Diamond Plate, balance mill finish; dual built-in vertical/horizontal baffles; two 2” machined hexfixing NPT ports in top ends of tank to accommodate transfer pump and/or vented cap, ports are internally reinforced. 2” NPT vented cap provided; four 6” long 2” x 2” angles welded in place for secure deck mounting; 3/4” NPT drain port with plug located at bottom edge of left head. Ships by truck freight.

**CHANGES MAY BE MADE TO PRODUCT WITHOUT NOTICE.
TO SEE OUR FULL LINE OF DRAWINGS GO TO WWW.AMERICANMOBILEPOWER.COM**

Order No.	Weight	Description	Page #
APP-210-M	1#	Magnetic Port Plug - 3/4” NPT	54
906001-4	1#	2” NPT Vented Cap	54

ALL TANKS FACTORY TESTED

It is the users responsibility to comply with local, state, and federal requirements. Tanks are intended for use with non-hazardous fluids and fluids with a flash point greater than 100 deg. F.

WARNING! Transfer tanks must not be connected to a vehicle fuel system as an auxiliary fuel tank.



American Transfer Tank System

Model ATT41120

Aluminum "L" Style - 112 Gallon

Tank Size: 59" long x 30" deep x 26" high

Designed for full size pickups.

Shipping Weight: 140#



Total aluminum construction; top facing built of Bright Diamond Plate, balance mill finish; dual built-in vertical/horizontal baffles; two 2" machined hexfixing NPT ports in top ends of tank to accommodate transfer pump and/or vented cap, ports are internally reinforced. 2" NPT vented cap provided; four 6" long 2" x 2" angles welded in place for secure deck mounting; 3/4" NPT drain port with plug located at bottom edge of left head. Ships by truck freight.

CHANGES MAY BE MADE TO PRODUCT WITHOUT NOTICE.

TO SEE OUR FULL LINE OF DRAWINGS GO TO WWW.AMERICANMOBILEPOWER.COM

Order No.	Weight	Description	Page #
APP-210-M	1#	Magnetic Port Plug - 3/4" NPT	54
906001-4	1#	2" NPT Vented Cap	54

ALL TANKS FACTORY TESTED

It is the users responsibility to comply with local, state, and federal requirements. Tanks are intended for use with non-hazardous fluids and fluids with a flash point greater than 100 deg. F.

WARNING! Transfer tanks must not be connected to a vehicle fuel system as an auxiliary fuel tank.

Transfer Pumps

**CHANGES MAY BE MADE TO PRODUCT WITHOUT NOTICE.
TO SEE OUR FULL LINE OF DRAWINGS GO TO WWW.AMERICANMOBILEPOWER.COM**

Order No.	Weight	Description
HP-100	14#	Petroleum Hand Pump
		<p>The Hand Pump is compatible with a wide variety of petroleum products and fits any container with a 2" NPT bung and tapered threads. Lightweight, die-cast aluminum housing. Stainless steel piston shaft and liner. Built-in anti-siphon valve to prevent leaks.</p> <p>Pumping Capacity: Up to 1/2 gallon or 1.9 liters/stroke cycle. 1/2 gallon setting for high volume, higher resistance; 1/4 gallon for low volume, low resistance.</p> <p>Inlet: 1" NPT Outlet: 3/4" NPT Hose: 3/4" x 8 ft. Dry Prime: 5 ft. minimum Nozzle: Thermoplastic unleaded nozzle. Built-in nozzle holder. Suction Pipe: Plastic, adjustable 22 to 40 inches Security: Handle can be padlocked.</p>
M-150	23#	Standard Volt Electric Pump
		<p>Application for low viscosity petroleum fuels such as gasoline, kerosene, and diesel fuel. Outdoor, year-round operating use with a temperature range of -20 to +125 degrees F. Designed for mounting on portable, vented storage tanks. Lightweight, corrosion-resistant, cast aluminum body. Convenient spin collar for easy installation.</p> <p>Pump Rate: Up to 15 GPM Duty Cycle: 30 min. on/30 min. off Input: 12 volt DC Motor: 1900 rpm Motor Protector: 20 amps Cord: 15 ft. of 12 gauge Bung: 2" NPT Inlet: 1" NPT Outlet: 3/4" NPT Hose: 3/4" x 12 ft. Buna-N Suction: Plastic, adjustable 22 to 40 inches Security: Nozzle can be padlocked. Also available with automatic shutoff.</p>
01A3AGM	1#	Electric Digital Fuel Meter
		<p>Designed for outdoor, year-round use on fuel transfer pumps in the 3 to 30 GPM (10 to 100 LPM) flow range. Calibrated at the factory for use with gasoline, diesel fuel or kerosene. Requires two AA batteries that can easily be replaced by the user. Approximate battery life is 9,000 hours. Installs easily to the above Electric pump, M-150, for maximum efficiency.</p>





Transfer Parts

CHANGES MAY BE MADE TO PRODUCT WITHOUT NOTICE.
TO SEE OUR FULL LINE OF DRAWINGS GO TO WWW.AMERICANMOBILEPOWER.COM

Order No.	Weight	Description	
APP-210-M	1#	Magnetic Port Plug - 3/4" NPT	
906001-4	1#	2" NPT Vented Cap	
ATT-200		Transfer Mounting Bracket	

22" Aluminum Reefer Tank

Original Equipment Replacement

AR2235

35 Gallon Capacity, 22" D x 23" L
Shipping Weight: 24#

AR2250

50 Gallon Capacity, 22" D x 34" L
Shipping Weight: 45#

AR2275

75 Gallon Capacity, 22" D x 51" L
Shipping Weight: 56#

A22100

100 Gallon Capacity, 22" D x 61" L
Shipping Weight: 60#



22" diameter rolled aluminum cylinder, domed ends are die stamped with front head recessed to accept bolt on fuel gauge; metal is mill finished; fill assembly includes chain mounted non-vented screw on cap; three 1/2" NPT top ports to accept the anti-spill vent, two 1/2" x 1/4" pick up and return line tubes; rectangular bottom mounted sump includes shielded brass drain/check plug assembly. Unit is packaged and ships by UPS. Unit meets all FHWA side mounted fuel tank requirements. Units are designed for use with "Diesel Fuel Only".

**CHANGES MAY BE MADE TO PRODUCT WITHOUT NOTICE.
TO SEE OUR FULL LINE OF DRAWINGS GO TO WWW.AMERICANMOBILEPOWER.COM**

Order No.	Weight	Description	Page #
FGA-2200	2#	Fuel Float Gauge	59
PRT-2200	1#	Pick-Up/Return Tube, 1/2" NPT x 1/4" NPT	59
FNC-2000	2#	2" Female Non-Vented Cap	59
ASV-0500	2#	1/2" NPT Anti-Spill Vent	59
BCV-0500	1#	Bottom Check Valve, Drain & Plug - 1/2" NPT	59

NOTE: AR-2250 does not include mounting hardware. See Reefer Mounting Kits, RMK-822-S, Page 48.



24" Aluminum Reefer Tanks



AR8535

35 Gallon Capacity, 24" D x 19" L
Shipping Weight: 38#

AR8550

50 Gallon Capacity, 24" D x 26.5" L
Shipping Weight: 45#

AR8575

75 Gallon Capacity, 24" D x 39" L
Shipping Weight: 56#

24" diameter, rolled aluminum cylinder, domed ends are die stamped with front head recessed to accept bolt on fuel gauge; metal is mill finished; fill assembly includes chain mounted non-vented screw on cap; three 1/2" NPT top ports to accept the anti-spill vent, two 1/2" x 1/4" pick up and return line tubes; rectangular bottom mounted sump includes shielded brass drain/check plug assembly. Unit is packaged and ships by UPS. Unit meets all FHWA side mounted fuel tank requirements. Units are designed for use with "Diesel Fuel Only".

**CHANGES MAY BE MADE TO PRODUCT WITHOUT NOTICE.
TO SEE OUR FULL LINE OF DRAWINGS GO TO WWW.AMERICANMOBILEPOWER.COM**

Order No.	Weight	Description	Page #
FGA-2200	2#	Fuel Float Gauge	59
PRT-2200	1#	Pick-Up/Return Tube, 1/2" NPT x 1/4" NPT	59
FNC-2000	2#	2" Female Non-Vented Cap	59
ASV-0500	2#	1/2" NPT Anti-Spill Vent	59
BCV-0500	1#	Bottom Check Valve, Drain & Plug - 1/2" NPT	59

NOTE: Mounting kit sold separately. See Reefer Mounting Kits, RMK-824-S, Page 48.

Reefer Mounting Products

Reefer Heavy Duty Mounting Kits

RMK-822-S

For Installation of 22" Reefer Tank
Mounting Kit Carton - 58#

PRE-PACKAGED KIT INCLUDES:
Heavy duty mounting kit.

This kit includes:

- (2) heavy duty brackets (RMK-824)
- (2) Stainless Steel Straps (ASA-5852S)
- (2) Frame mounting hardware (ASK-205-R)



RMK-824-S

For Installation of 24" Reefer Tank
Mounting Kit Carton - 58#

PRE-PACKAGED KIT INCLUDES:
Heavy duty mounting kit.

This kit includes:

- (2) heavy duty brackets (RMK-824)
- (2) Stainless Steel Straps (ASA-6357S)
- (2) Frame mounting hardware (ASK-205-R)

CHANGES MAY BE MADE TO PRODUCT WITHOUT NOTICE.

TO SEE OUR FULL LINE OF DRAWINGS GO TO WWW.AMERICANMOBILEPOWER.COM

Order No.	Weight	Description	Page #
RMK-824	12#	Heavy Duty Cradle Brackets (Radius is rubber lined)	59
ASA-5852S	5#	Stainless Steel Strap Complete w/ Ny-Loc Nuts, 22" Tank	59
ASA-6357S	5#	Stainless Steel Strap Complete w/ Ny-Loc Nuts, 24" Tank	59
ASK-205-R	3#	Frame Mounting Hardware	59



Reefer Mounting Products

Reefer Heavy Duty Mounting Kits

RMK-822-S/3

For Installation of 75 gallon 22" Reefer Tank
Mounting Kit Carton - 87#

PRE-PACKAGED KIT INCLUDES:
Heavy duty mounting kit.

This kit includes:

- (3) heavy duty brackets (RMK-824)
- (3) Stainless Steel Straps (ASA-5852S)
- (3) Frame mounting hardware (ASK-205-R)

RMK-824-S/3

For Installation of 75 gallon 24" Reefer Tank
Mounting Kit Carton - 87#

PRE-PACKAGED KIT INCLUDES:
Heavy duty mounting kit.

This kit includes:

- (3) heavy duty brackets (RMK-824)
- (3) Stainless Steel Straps (ASA-6357S)
- (3) Frame mounting hardware (ASK-205-R)



CHANGES MAY BE MADE TO PRODUCT WITHOUT NOTICE.

TO SEE OUR FULL LINE OF DRAWINGS GO TO WWW.AMERICANMOBILEPOWER.COM

Order No.	Weight	Description	Page #
RMK-824	12#	Heavy Duty Cradle Brackets (Radius is rubber lined)	59
ASA-5852S	5#	Stainless Steel Strap Complete w/ Ny-Loc Nuts, 22" Tank	59
ASA-6357S	5#	Stainless Steel Strap Complete w/ Ny-Loc Nuts, 24" Tank	59
ASK-205-R	3#	Frame Mounting Hardware	59

Reefer Assembly Parts

CHANGES MAY BE MADE TO PRODUCT WITHOUT NOTICE.
 TO SEE OUR FULL LINE OF DRAWINGS GO TO WWW.AMERICANMOBILEPOWER.COM

Order No.	Weight	Description	
FGA-2200	2#	Fuel Float Gauge	
PRT-2200	1#	Pick-Up/Return Tube, 22" tanks 1/2" NPT x 1/4" NPT	
PRT-2400	1#	Pick-Up/Return Tube, 24" tanks 1/2" NPT x 1/4" NPT	
FNC-2000	2#	2" Female Non-Vented Cap	
ASV-0500	2#	1/2" NPT Anti-Spill Vent	
BCV-0500	1#	Bottom Check Valve, Drain & Plug - 1/2" NPT	
RMK-824	12#	Heavy Duty Cradle Brackets (Radius is rubber lined)	
ASA-5852S	5#	Stainless Steel Strap Complete	
ASA-6357S		Use Part No. ASA-5852S-22" Tank Use Part No. ASA-6357S-24" Tank	
ASK-205-R	9#	Frame Mounting Hardware	
FNC-2000-LC	2#	2" Female Non-Vented Locking Cap	



American Wet Tank System

Model A2000

Gross Dimensional Capacity: 50 Gallons

Mounting Kit Contents: Part Number ASK-200

Qty	Description
4	Pre-drilled and powder coated chassis mounting angles
4	Pre-drilled rubber mounting pads
4	Two inch (2") plated compression springs
4	Cap screws - 5/8" - 11 x 3-1/2", grade 5
4	Ny-Loc nuts - 5/8" - 11
8	Plated flat washers - 5/8"

Materials Required To Complete Installation:

Qty	Description
8	Cap screws 1/2", grade 5 (length determined by installer)
8	Ny-Loc Nuts - 1/2" diameter
16	1/2" washers

Pre-Packaged Kit Includes:

Polyethylene tank assembly with (2) 2" NPT bottom ports, the tank itself is factory mounted and secured to the predrilled mounting base with (6) bolts and ny-loc nuts. A compression nut is torqued against the bottom of the base. Do NOT remove torqued nuts. The kit also includes a screw-in diffuser, a sight-temperature gauge (mounted 5" on center), (1) 2" to 1-1/4" plated reducer bushing, and the ASK-200 mounting kit.

This wet tank assembly has been designed for an end dump trailer application using either a two or three line system.

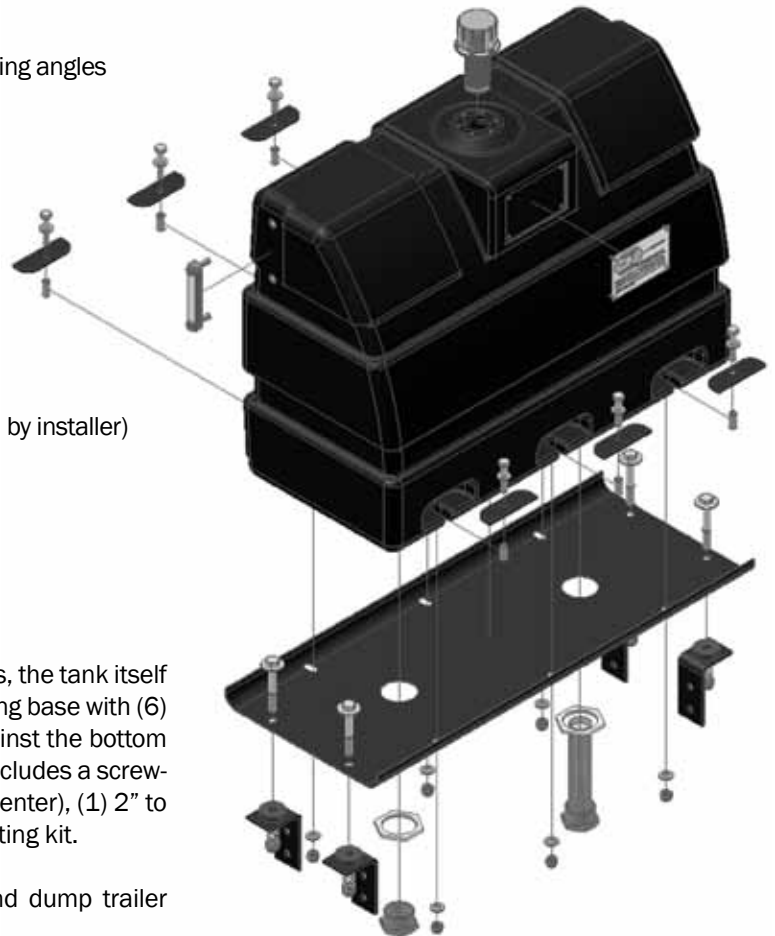

WARNING: MAXIMUM HYDRAULIC CYCLE TIME MUST NOT EXCEED 5 MINUTES. LONGER RUNNING TIME MAY RESULT IN EXCESSIVE HEAT BUILD UP AND SUBSEQUENT DAMAGE.

OPERATING TEMPERATURE: DO NOT EXCEED 180°

American Wet Tank System

Model A2000

INSTRUCTIONS:

- Position tank and base assembly on frame rails of the truck chassis as desired.
- Position chassis mounting angles so that the double pre-drilled holes are positioned against the frame rail and the single ($11/16$ " hole is positioned upward against the mounting base. (see diagram at right)
Note: The top of the mounting angle should be flush with the top of the chassis rail as shown.
- Using the pre-drilled mounting angles as a guide, mark both the frame rail and tank mounting angles. Chassis requires use of a $9/16$ " drill bit while the mounting base requires an $11/16$ " drill bit. Drill holes and bolt the four mounting angles into place.
Note: The rubber pads should be above the top of the frame rails. (see diagram at right)
- National Pipe Thread port openings:
The American Wet Tank System is designed with two 2" NPT metal port openings in the bottom of the tank. Each fitting is molded securely in the tanks and features an exterior mounted compression nut. These nuts are torqued to tolerance at the factory and **SHOULD NOT BE DISTURBED**. The system allows either port to be used as a suction or return line. Further, the assembly may be plumbed for use as a two or three line system. (see diagram at right)
- DIFFUSER INSTALLATION:**
Simply remove diffuser unit from packaging, seal threads using standard pipe dope only and screw into port of your selection. Tighten fitting into place **USING CARE NOT TO OVER TIGHTEN**. (see diagram at right)
Note: Installed diffuser provides 1-1/4" NPT opening to accommodate hose connection.
- REDUCER BUSING:** is provided for the second port (2" to 1-1/4"). Again, using standard pipe dope on threads and taking caution not to over tighten. This port is ready for hose connection if using a three line system or may be plugged if a two line system is desired. (see diagram at right)
Note: Use torque required to seat either diffuser or reducer bushing. Taking care not to overtighten.





7. Install pre-assembled tank and mounting base: secure with 5/8" x 4-1/2" cap screws, washers, springs and lock nuts as supplied in mounting kit. (ASK-200) (see main diagram)

Note: Tighten the 5/8" locknuts until the compressed length of the spring is 1-1/2" (see diagram at right)

DO NOT COMPRESS SPRINGS COMPLETELY



8. **FILL CAP:** Remove filter/breather cap from its carton; re-connect chain and mount in bayonet style closure. Maximum fill is 2" below bayonet closure.

Note: Filter/breather cap should be periodically cleaned or replaced to prevent plugging and possible system damage.

9. Install Notices In-Cab

You are now ready to begin plumbing the system of your choice.

TANK LABELING



These Labels are installed on the tank by the manufacturer.

IN-CAB NOTICE



INSTALLER:

Metal "Notice" Label must be placed in-cab. Peel backing and press onto a prominent in-cab location.

American Wet Tank System

Model A3000 & A4000

Mounting Kit Contents: Part Number ASK-200

Qty	Description
4	Pre-drilled and powder coated chassis mounting angles
4	Pre-drilled rubber mounting pads
4	Two inch (2") plated compression springs
4	Cap screws - 5/8" - 11 x 4-1/2", grade 5
4	Ny-Loc nuts - 5/8" - 11
8	Plated flat washers - 5/8"

Materials Required To Complete Installation:

Qty	Description
8	Cap screws 1/2", grade 5 (length determined by installer)
8	Ny-Loc nuts - 1/2" diameter
16	1/2" washers

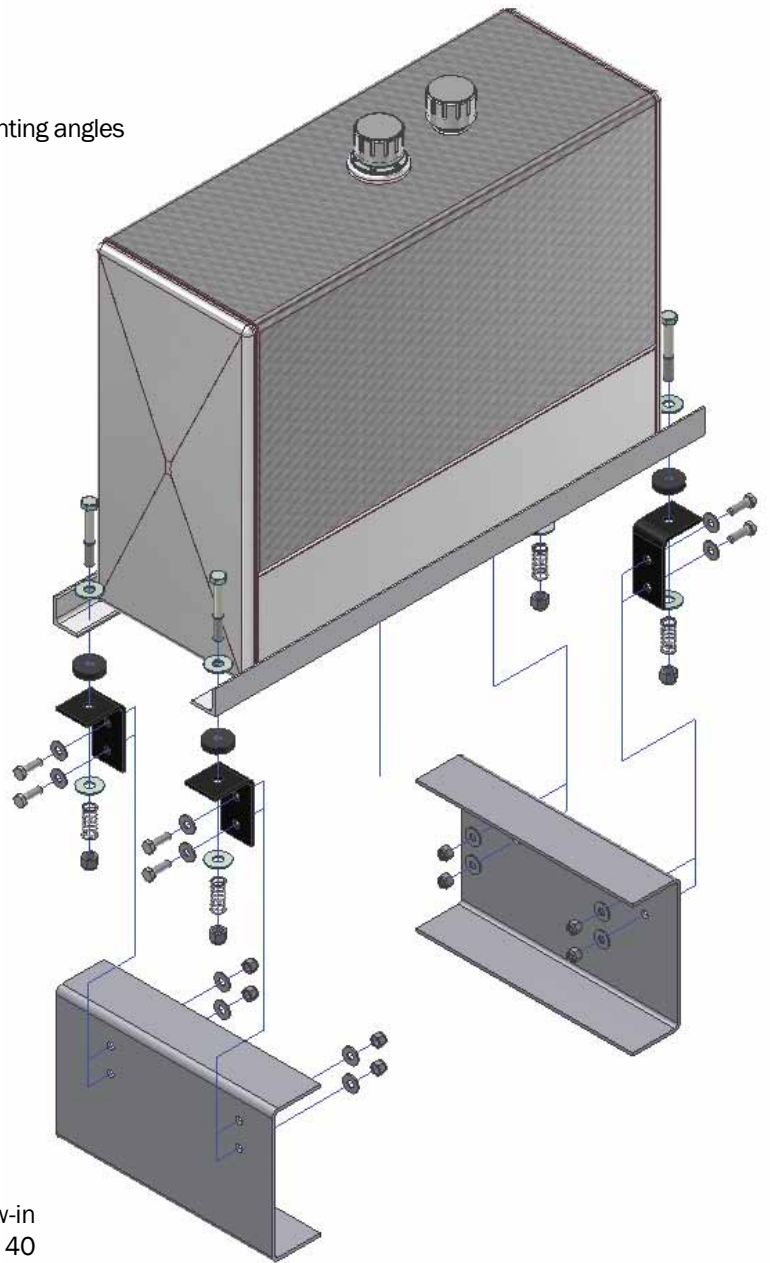

Pre-Packaged Kit Includes:

Steel or aluminum tank assembly with two 1-1/4" screw-in NPT bottom ports, filler/breather assembly including a 40 micron filter/breather cap (chain mounted), auxiliary vent, and the ASK-200 mounting kit.

This wet tank assembly has been designed for a dump trailer application using either a two or three line system.



American Wet Tank System Model A3000 & A4000

INSTRUCTIONS:

1. Position tank and base assembly on frame rails of the truck chassis as desired.

2. Position chassis mounting angles so that the double pre-drilled holes are positioned against the frame rail and the single ($11/16$ " hole is positioned upward against the tank mounting angles. (see diagram at right)

Note: The top of the mounting angle should be flush with the top of the chassis rail.

3. Using the pre-drilled mounting angles as a guide, mark both the frame rail and tank mounting angles. Chassis requires use of a $9/16$ " drill bit while the mounting angles require an $11/16$ " drill bit. Drill holes and bolt the four mounting angles into place.

4. Place tank assembly across frame with mounting rails lined up directly over top holes in mounting angles. Mark and drill using a $11/16$ " drill bit

5. Place rubber mounting pads on top of the four mounting angles. (see diagram at right)

Note: The rubber pads should be above the top of the frame rails.

6. Reposition tank over pads and angles, install bolts and springs as shown in exploded view. (see diagram at right)

7. National Pipe Thread port openings: (see diagram at right)
The American Wet Tank System is designed with two $1-1/4$ " NPT port openings in the bottom of the tank. The system allows either port to be used as a suction or return line.

The assembly may be plumbed for use as a two or three line system.



American Wet Tank System

Model A3070 & A4070

Mounting Kit Contents: Part Number ABK-340

Qty	Description
1	Heavy duty mounting base panel
2	2" wide strap assemblies including (4) ny-loc nuts w/ springs
4	13"x 2"x 1" rubber mounting pads
1	ASK-200 frame mounting kit

Materials Required To Complete Installation:

Qty	Description
8	Cap screws 1/2", grade 5 (length determined by installer)
8	Ny-loc nuts - 1/2" diameter
16	1/2" washers

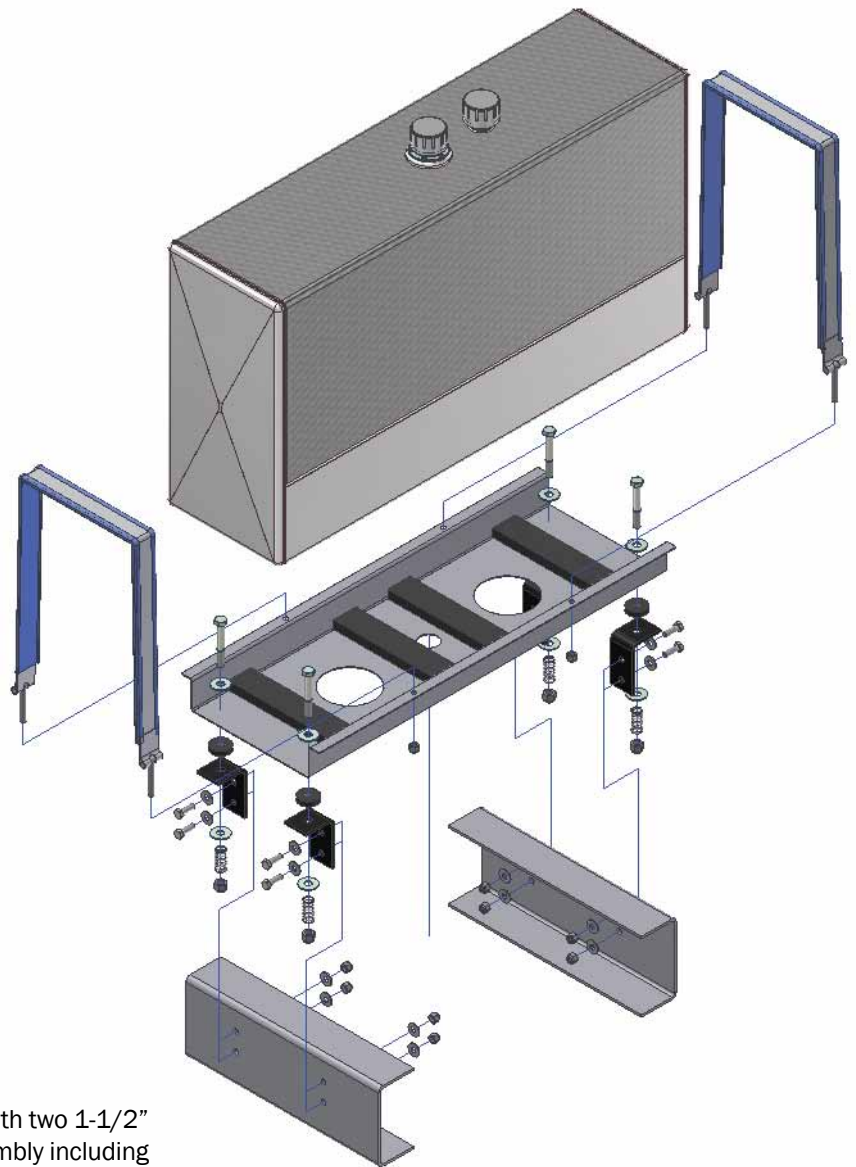

Pre-Packaged Kit Includes:

Steel or aluminum tank assembly (70 gallon) with two 1-1/2" screw-in NPT bottom ports, filler/breather assembly including a 40 micron filter/breather cap (chain mounted), auxiliary vent, and the ABK-340 mounting base kit.

This wet tank assembly has been designed for use as a two or three line system.



American Wet Tank System Model A3070 & A4070

INSTRUCTIONS:

1. Position base panel on frame rails of the truck chassis as desired.
2. Position chassis mounting angles so that the double pre-drilled holes are positioned against the frame rail and the single (11/16") hole is positioned upward against the tank mounting base panel. (see diagram at right)

Note: The top of the mounting angle should be flush with the top of the chassis rail.

3. Using the pre-drilled mounting angles as a guide, mark both the frame rail and tank mounting base panel. Chassis requires use of a 9/16" drill bit while the mounting base requires an 11/16" drill bit. Drill holes and bolt the four mounting angles into place. (see diagram at right)

4. Next, place base panel over angles and install bolts and springs as shown in exploded view. (see diagram at right)

Note: The rubber pads should be above the top of the frame rails.

5. Place the (4) 13" x 2" x 1" rubber mounting pads on the base panel as shown in exploded view.

Center tank on base panel, install strap assemblies. (see diagram at right)

Rubber will conform to tank bottom as straps are tightened.

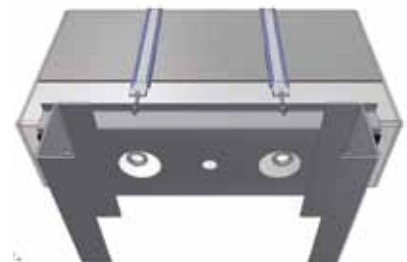
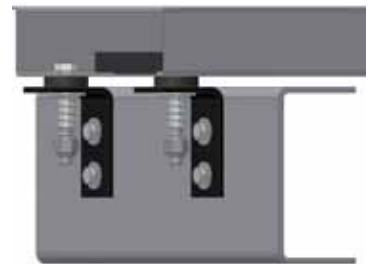

American Wet Tank System

Model A3500 & A4500

Also Includes: A3525, A3535, A3575, A35100-ST
A4525, A4535, A4575, A45100-ST

A3575 - A4575

75 Gallon Units

Require Three Bracket Assemblies
Use Kit Number:
AMK-624-C/3 (Carbon Steel)
AMK-624-S/3 (Stainless)

A35100-ST - A45100-ST

100 Gallon Units

Require Four Bracket Assemblies
Use 2 of the following:
AMK-624-C (Carbon Steel)
AMK-624-S (Stainless)





American Wet Tank System

Model A3500 & A4500

Mounting Kit Contents: Part Number AMK-624-C (carbon steel)
Part number AMK-624-S (stainless steel)

Qty	Description
2	"J" brackets - powder coated, radius is rubber lined (affixed)
2	2" wide strap assemblies including (4) ny-loc nuts

Materials Required To Complete Installation:

Qty	Description
4	5/8" - grade 5 bolts (length determined by installer)
4	Ny-Loc nuts - 5/8" diameter
8	5/8" washers

Pre-Packaged Kit Includes:

Steel or aluminum tank assembly (25 gallon through 100 gallon) with three 1-1/4" NPT ports (75 gallon have 1-1/2" NPT ports), (100 gallon have 2" NPT ports), the 50 gallon and larger units include auxiliary mushroom vent in tank for increased air exchange; each is provided with a filler/breather assembly-including 40 micron filter/breather cap (chain mounted) with nylon strainer basket and bayonet closure; all ports in each unit are internally diffused (Except 100 gallon); one port plug provided; all steel parts are powder-coated black; saddlemount bracket and strap assemblies are rubber shielded.

INSTRUCTIONS:

1. Position the top of the cradle bracket flush with truck frame rail.
2. Attach brackets to frame rail with at least (2) 5/8", grade 5 bolts (per bracket).

Note: Brackets should be placed within 2" from ends of tank, 75 gallon tanks require an extra bracket (and strap) placed on either side of fill cap, at least 1/2" from weld. 100 gallon tanks require two extra brackets (and straps), spaced evenly and at least 1/2" from weld.

3. Place tank against brackets and firmly tighten nuts to straps (not more than 25 ft-lbs of torque.)
4. Install plumbing. All plumbing and fitting connections attached to tanks must be properly supported into same moving plane as the tank in order to keep plumbing and fittings from creating a metal fatigue fracture outside of port weld. We suggest using a hose support mount (which we offer.)

American Reefer System

Models AR2235, AR2250, AR2275, AR8535, AR8550 & AR8575

AR2275, AR8575

75 Gallon Units

Require Three Bracket Assemblies

Use Kit Number:

RMK-822-S/3 (22")

RMK-824-S/3 (24")

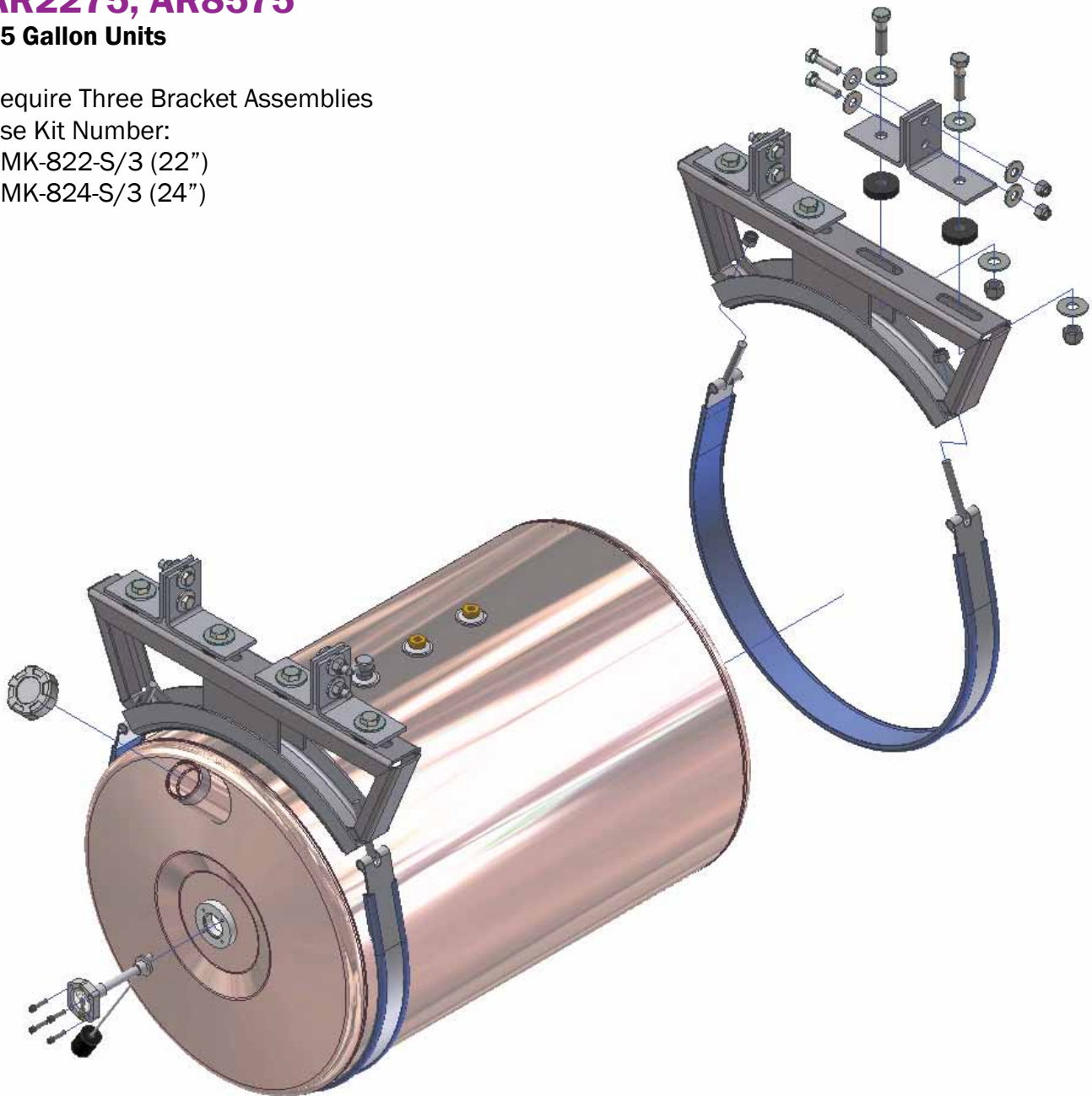



American Reefer System

Models AR2235, AR2250, AR2275, AR8535, AR8550 & AR8575

Mounting Kit Contents: Part Number RMK-822-S (22")
Part number RMK-824-S (24")

Qty	Description
2	Heavy Duty Cradle Brackets - powder coated, radius is rubber lined (affixed)
2	2" wide strap assemblies including (4) ny-loc nuts
2	ASK-200R Frame Mounting Kit

Pre-Packaged Kit Includes:

Aluminum tank assembly (35 gallon through 75 gallon) with 2" NPT fill neck and non-vented cap; float gauge assembly (installed); three 1/2" NPT top ports to accept the anti-spill vent, two 1/2" x 1/4" NPT pick up an return line tubes (installed); one brass drain/check plug assembly; two pre-punched and powder coated heavy duty brackets, two rubber shielded stainless steel straps with ny-loc nuts; and the under body mounting hardware kit.

INSTRUCTIONS:

1. Position mounting angles so that the double pre-drilled holes are positioned against the frame rail and the single hole is facing down.

Note: The mounting angle should be flush with the frame rail.

2. Mark holes on frame rail and drill using a 9/16" drill bit.
3. Reposition angles and mount using supplied 1/2" bolt assemblies.
4. Position cradle bracket under mounting angles and attach using supplied 5/8" bolt assemblies, using the rubber spacer between cradle bracket and angles.
5. Place tank against brackets and firmly tighten nuts to straps (not more than 25 ft-lbs of torque).

INDEX

<u>Part No.</u>	<u>Description</u>	<u>Page #</u>			
01A3AGM	Electric Digital Fuel Meter	53	ABA-138	Breather Vent - 3/8" NPT	39
57XL-10-3HN	Fill Cap Assembly w/ 3" Riser	38	ABA-16	Breather Vent - 1" NPT	39
57XL-10-6DP	Fill Cap Assembly w/ 6" Dipstick	38	ABC-315	Filter/Breather Cap Only	39
57XL-40-5P	Fill Assembly w/ Pressure Cap	38	ABK-340-C	Mounting Base Kit Complete	
906001-4	2" NPT Vented Cap	54		*See Mounting Kits	36
A2000	Polyethelene Upright - 50 Gallon	4	ABK-340-C	Carbon Mounting Kit - 70 Gallon	36
A2000	Poly Upright Tank System	60	ADA-250	Diffuser Assembly - 8" long - 2" to 1-1/4"	40
A3000	Steel Upright - 50 Gallon	5	ADA-250	Diffuser Assembly	40
A3000	Steel Upright Tank System	63	AFA-038	3/8" Aluminum Weld Flange	41
A30100-ST	Steel Upright - 100 Gallon	8	AFA-050	1/2" Aluminum Weld Flange	41
A3035-ST	Steel Upright - 35 Gallon	6	AFA-075	3/4" Aluminum Weld Flange	41
A3070	Steel Upright - 70 Gallon	7	AFA-100	1" Aluminum Weld Flange	41
A3070	Steel Upright Tank System	65	AFA-125	1-1/4" Aluminum Weld Flange	41
A3100	Steel Sidemount - 10 Gallon	25	AFA-150	1-1/2" Aluminum Weld Flange	41
A3107	Steel Sidemount - 7 Gallon	24	AFA-200	2" Aluminum Weld Flange	41
A3150	Steel Sidemount - 15 Gallon	26	AFA-401	Aluminum Fill Adapter	41
A3250	Steel Sidemount - 25 Gallon	27	AFC-330	Fill Assembly	38
A3300	Steel Sidemount - 30 Gallon	28	AFC-330	Fill Cap Assembly w/out cap	38
A330SL	Specialty Hydraulic Tank - 30 Gallon	31	AFC-350	Fill Cap Assembly	38
A3400	Steel Sidemount - 40 Gallon	29	AFS-050	1/2" Steel Weld Flange	41
A3500	Steel Saddlemount - 50 Gallon	12	AFS-075	3/4" Steel Weld Flange	41
A3500	Steel Saddlemount Tank System	67	AFS-100	1" Steel Weld Flange	41
A35100-ST	Steel Saddlemount - 100 Gallon	17	AFS-125	1-1/4" Steel Weld Flange	41
A3525	Steel Saddlemount - 25 Gallon	13	AFS-150	1-1/2" Steel Weld Flange	41
A3535	Steel Saddlemount - 35 Gallon	14	AFS-200	2" Steel Weld Flange	41
A3560-ST	Steel Saddlemount - 60 Gallon	15	AFS-301	Steel Fill Adapter	41
A3575	Steel Saddlemount - 75 Gallon	16	AHS-125	Hydraulic Hose Support Kit	44
A4000	Aluminum Upright - 50 Gallon	9	AHS-150	Hydraulic Hose Support Kit	44
A4000	Aluminum Upright Tank System	63	AHS-200	Hydraulic Hose Support Kit	44
A4035-ST	Aluminum Upright - 35 Gallon	10	AMB-312	Mounting Base Panel	37
A4070	Aluminum Upright - 70 Gallon	11	AMB-405	Mounting Base Panel	37
A4070	Aluminum Upright Tank System	65	AMB-405HD	Mounting Base Panel - Heavy Duty	37
A4150	Aluminum Sidemount - 15 Gallon	30	AMK-624	1" Bracket Only	37
A4500	Aluminum Saddlemount - 50 Gallon	18	AMK-624-C	Carbon Steel Mounting Kit Complete	34
A4500	Aluminum Saddlemount Tank System	67	AMK-624-C/3	Carbon Mounting Kit - 75 Gallon	35
A4500-2S90-ST			AMK-624-S	Hydraulic Stainless Mounting Kit	34
	Specialty Aluminum Saddlemount Tank		AMK-624-S/3	Stainless Mounting Kit - 75 Gallon	35
	- 50 Gallon	33	AMP-205	Rubber Inserts for Heavy Duty	
A45100-ST	Aluminum Saddlemount - 100 Gallon	23		Mounting Base Panel	37
A4525	Aluminum Saddlemount - 25 Gallon	19	AMP-205	Mounting pads	37
A4535	Aluminum Saddlemount - 35 Gallon	20	AMP-305	"J" Bracket Rubber	37
A4535-DS90-ST			AMP-400	Channel Rubber	37
	Specialty Aluminum Saddlemount Tank		AMP-40053	53" Channel Rubber (for strap)	37
	- 35 Gallon	32	AMT-307	Upright Steel Tank Only	7
A4560-ST	Aluminum Saddlemount - 60 Gallon	21	AMT-350	Steel Saddlemount Tank Only	12
A4575	Aluminum Saddlemount - 75 Gallon	22	AMT-351	Steel Saddlemount Tank Only	17
ABA-12	Breather Vent - 3/4" NPT	39	AMT-352	Steel Saddlemount Tank Only	13
			AMT-353	Steel Saddlemount Tank Only	14



INDEX continued

AMT-356	Steel Saddlemount Tank Only	15	ASK-210	Heavy Duty Chassis Mounting Kit	
AMT-357	Steel Saddlemount Tank Only	16	ASV-0500	1/2" NPT Anti-Spill Vent	59
AMT-407	Upright Aluminum Tank Only	11	ATT-200	Transfer Mounting Bracket	54
AMT-450	Aluminum Saddlemount Tank Only	18	ATT4070	Aluminum Upright - 70 Gallon	44
AMT-451	Aluminum Saddlemount Tank Only	23	ATT4072	Aluminum Deck Mount - 72 Gallon	48
AMT-452	Aluminum Saddlemount Tank Only	19	ATT4075	Aluminum "L" Style - 75 Gallon	50
AMT-453	Aluminum Saddlemount Tank Only	20	ATT4088	Aluminum "L" Style - 100 Gallon	51
AMT-456	Aluminum Saddlemount Tank Only	21	ATT4090	Aluminum Upright - 90 Gallon	47
AMT-457	Aluminum Saddlemount Tank Only	22	ATT41020	Aluminum Deck Mount - 102 Gallon	49
APC-160	6" Inspectin Port Cover	40	ATT41120	Aluminum "L" Style - 112 Gallon	52
APC-160-S	Stainless Port Cover	40	BCV-0500	Bottom Check Valve, Drain & Plug - 1/2" NPT	59
APP-202	Steel Port Plug - 1-1/2" NPT	41	FCS-537W	Filler Cap Assembly Weather Proof	38
APP-210	Steel Port Plug - 1" NPT	41	FCS-557	Non-Vented Cap Assembly	38
APP-210-M	Magnetic Port Plug - 3/4" NPT	41	FGA-2200	Fuel Float Gauge	59
APP-214	Port Reducer Bushing - plated, 1-1/4" to 3/4"	41	FNC-2000	2" Female Non-Vented Cap	59
APP-220	Steel Port Plug - 2" NPT	41	FNC-2000-LC	2" female Non-Vented Locking Cap	59
APP-225	Port Reducer Bushing - plated, 2" x 1-1/4"	41	HDF-6	Diesel Fuel Neck	39
AQD-1010	1" Quick Disconnect-Complete	45	HP-100	Petroleum Hand Pump	53
AQF-1010	1" Female Couler End	45	LC57XL-40N	Lockable Fill Cap Assembly	38
AQM-1010	1" Male Coupler End	45	LIT-1250-10P	In Tank Filter	40
AR22100	Aluminum Reefer Tank - 22"	55	LPBV-20	1 -1/4" Low Pressure Ball Valve	45
AR2235	Aluminum Reefer Tank - 22"	55	LTM-25	NPT Suction Strainer	40
AR2235	Aluminum Reefer Tank - 22"	69	LTM-50	Suction Strainer, 3" to 2"	40
AR2250	Aluminum Reefer Tank - 22"	55	M-150	Standard Volt Electric Pump	53
AR2250	Aluminum Reefer Tank - 22"	69	PRT-2200	Pick-Up/Return Tube	59
AR2275	Aluminum Reefer Tank - 22"	55	RMK-822-S	22" Reefer Mounting Kit	57
AR2275	Aluminum Reefer Tank - 22"	69	RMK-822-S/3	22" Reefer Mounting Kit	58
AR8535	Aluminum Reefer Tank - 24"	56	RMK-824	Heavy Duty Cradle Brackets (Radius is rubber lined)	59
AR8535	Aluminum Reefer Tank - 24"	69	RMK-824-S	24" Reefer Mounting Kit	57
AR8550	Aluminum Reefer Tank - 24"	56	RMK-824-S/3	24" Reefer Mounting Kit	58
AR8550	Aluminum Reefer Tank - 24"	69	WL-HK-12-12-2L	Wet Line Hose Kits/2 Line System	43
AR8575	Aluminum Reefer Tank - 24"	56	WL-HK-12-12-3L	Wet Line Hose Kits/3 Line System	42
AR8575	Aluminum Reefer Tank - 24"	69	WL-HK-16-24-2L	Wet Line Hose Kits/2 Line System	43
ARM-1010	Rapid Mount Assembly	45	WL-HK-16-24-3L	Wet Line Hose Kits/3 Line System	42
ASA-355	Carbon Steel Strap Assembly	37	WL-HK-20-24-2L	Wet Line Hose Kits/2 Line System	43
ASA-355-S	Stainless Steel Strap Assembly	37	WL-HK-20-24-3L	Wet Line Hose Kits/3 Line System	42
ASA-5852S	Stainless Steel Strap Complete w/ Ny-Loc Nuts, 22" Tank	59	WL-HK-9-8-2L	Wet Line Hose Kits/2 Line System	43
ASA-6257S	Stainless Steel Strap Complete w/ Ny-Loc Nuts, 24" Tank	59	WL-HK-9-8-3L	Wet Line Hose Kits/3 Line System	42
ASG-105	Sight/Temperature Gauge	40			
ASK-200	Chassis Mounting Kit	37			
ASK-200G	Gusseted Mounting Kit	37			
ASK-205-R	Frame Mounting Hardware	59			

STEEL POLYETHYLENE ALUMINUM STEEL POLYETHYLENE ALUMINUM STEEL

STEEL POLYETHYLENE ALUMINUM STEEL POLYETHYLENE ALUMINUM STEEL POLYETHYLENE ALUMINUM STEEL POLYETHYLENE ALUMINUM STEEL

STEEL POLYETHYLENE ALUMINUM STEEL POLYETHYLENE ALUMINUM STEEL POLYETHYLENE ALUMINUM STEEL



A3150



A2000



A4150



A3250



A3535



A3300



A4535



A3400



A3500

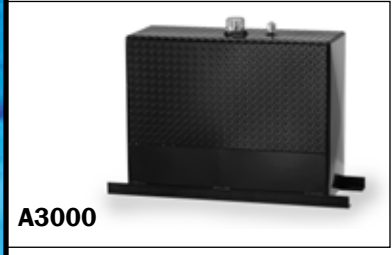

A3000

• CALL TODAY •
• WE SHIP •
JUST IN TIME!
1-800-634-8265



A4500



A3070



A4070



A3575



A4000



A3525



A4525



A4575

STEEL POLYETHYLENE ALUMINUM STEEL POLYETHYLENE ALUMINUM STEEL