



## VALVES

Y-STRAINER - BRASS  
200 WOG/CWP

### FEATURES & APPLICATIONS:

- 200 WOG/CWP
- NPT Thread

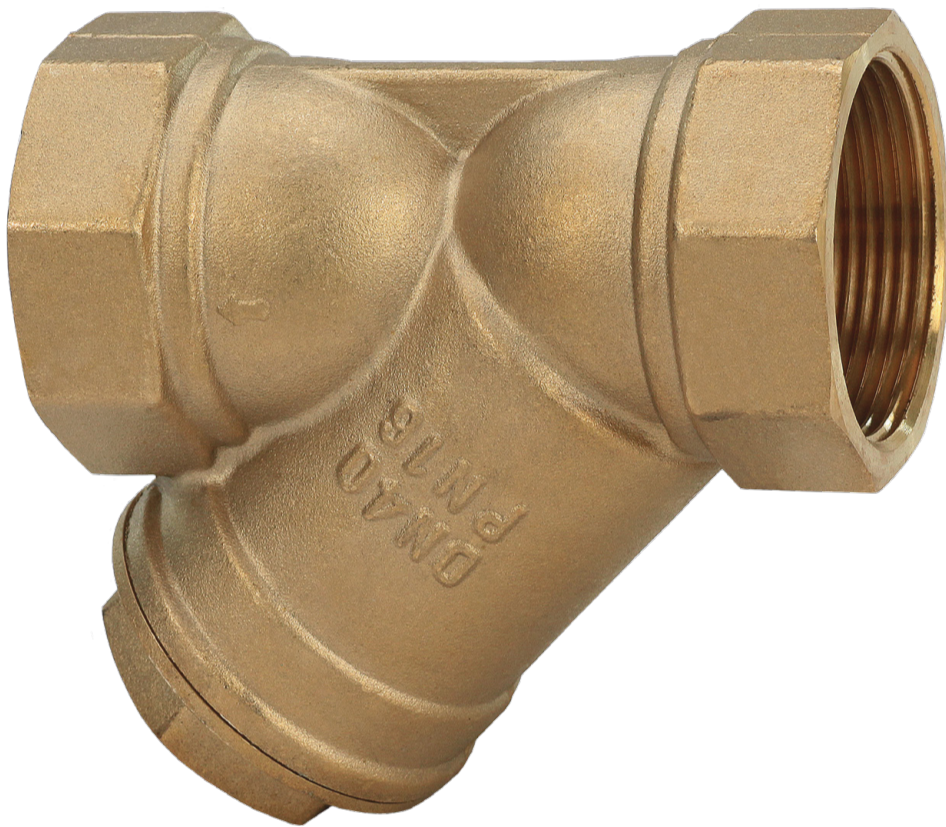

### TECHNICAL DATA:

- **WOG** = Rating indicates the maximum non-shock pressure at ambient temperatures at which the valve may be used.
- **CWP** = Cold working pressure

**WOG:** Water, Oil & Gas: This was an older, generic pressure rating call-out which has been largely replaced by CWP. In this designation, "GAS" refers to any non-flammable, compressible fluid in a gaseous state. It does not imply a product's suitability or third-party approval for use with flammable gases. Similarly, in this designation, "Oil" does not imply a product's third-party approval for use with any petroleum products.

### BRASS

Size	Part #
1/2"	YS050
3/4"	YS075
1"	YS100
1-1/4"	YS125
1-1/2"	YS150
2"	YS200

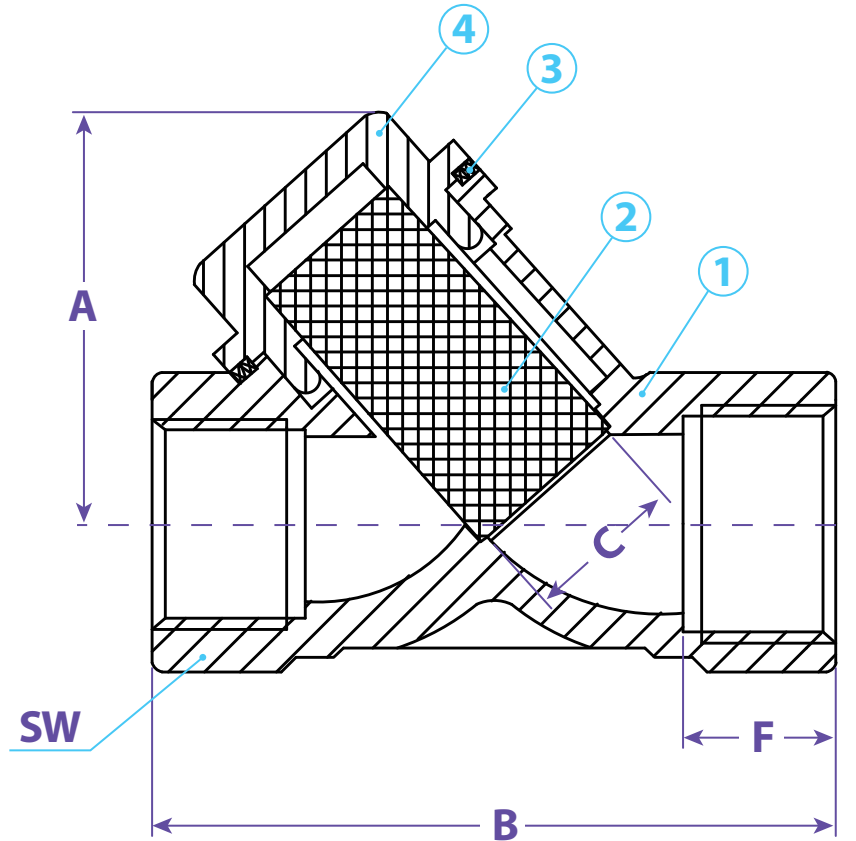

Dimensions						
Size	A	B	C	F	SW	Part #
1/2"	1.54	2.20	.51	.47	.96	YS050
3/4"	1.85	2.71	.79	.47	1.30	YS075
1"	1.97	2.99	.79	.55	1.52	YS100
1-1/4"	2.56	2.52	1.06	.61	1.85	YS125
1-1/2"	2.91	4.01	1.26	.75	2.11	YS150
2"	3.46	4.72	1.65	.75	2.64	YS200

Nomenclature & Material		
No.	Description	Material
1	Body	Brass
2	Filter	304 SS
3	Seal	PTFE
4	Cap	Brass

TITLE **Y-STRAINER VALVE**

**DISCLAIMER**  
All drawings and specifications are subject to change without notice. Drawings represent general dimensions of our products. Seal Fast Inc. cannot guarantee the dimensions will exactly match those in the drawing. The drawing is the property of Seal Fast Inc. Copying or reproduction of this drawing is expressly prohibited.

MATERIAL

**BRASS**

**DRAWING NOT TO SCALE**

PART #

**YS...**